

RADIO — ELECTRONICS

AUGUST 1954

TELEVISION • SERVICING • HIGH FIDELITY

HUGO GERNSBACH, Editor

In this issue:

Horizontal
Instability
In TV Sets

•
Junction
Transistor
Checker

•
Printed Circuits
in
Hi-Fi FM Tuners

•
A Low-Cost
Amplifier

•
Frequency
Compensation
For Your Scope



35¢

U. S. and
CANADA

New Solar Battery Produces Power from Light

(See page 4)

**5 years of nationwide
TV advertising...**

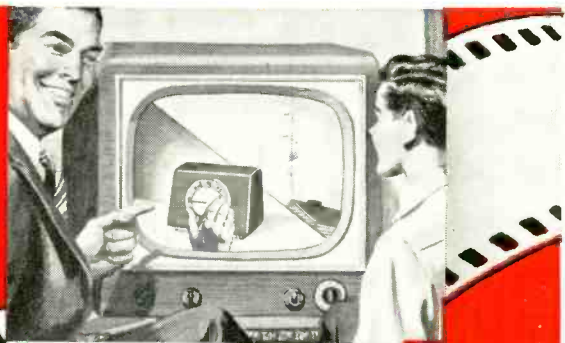

**Alliance Tenna Rotor
TV PROMOTION
blankets the country...**

Biggest TV Ad Campaign Pre-Sells For You!

Styling that sells on sight!

Model T-10,
compact—neat.
Electrically con-
trolled with di-
rection indicator.
Price **\$39.95.**

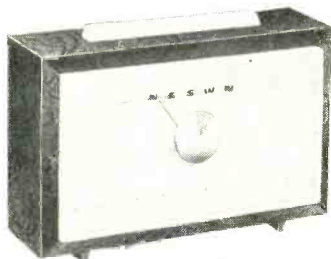

New model Alliance Ten-
na-Rotors pack more eye-
appeal, more buy-appeal.
Record-breaking sales
prove it!

**ALLIANCE RATED TOP TV SPOT
ADVERTISER!**

Among all national TV spot advertisers, according to
*Rorabaugh reports, Alliance ranked No.14 in 1953.

Television — Newspapers — Magazines
advertise the full Alliance line—Alliance
Tenna-Rotors—UHF Converters—Boost-
ers. Boost your profits with the line that
backs you!

*Recognized National TV Spot reporting service.

The Alliance line is styled right—priced
right—IT PAYS TO BACK THE LINE THAT
DELIVERS THE MOST POWERFUL TV
ACCESSORY CAMPAIGN IN HISTORY!

Over 2,000,000 Alliance Tenna-Rotors now in use!



**Model U-83—AUTOMATIC—THE
ONLY FULLY AUTOMATIC ROTATOR
—AN EXCLUSIVE FEATURE—JUST "SET
IT—FORGET IT!" Price \$44.95.**

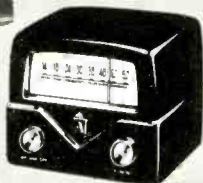

**NEW! Alliance electronic
garage door operator...
LIFT-A-DOR!**

Alliance

MANUFACTURING COMPANY
Alliance, Ohio

I doubled my income

by learning Radio-Television with N.R.I.

"My income has doubled since I began my NRI course," writes Bill Channer of Kelso, Oregon. "I have been in business now about five years, and have one of the leading Radio and Television sales and service shops in the area. My business is steadily growing. I employ two full-time servicemen in addition to myself and expect to need more help. The real money today is in Television installation and service. We also do a good Radio service business, as well as installation and service work for several department stores in our area. My NRI training has paid off well—more than doubling my income. Training at home did it."

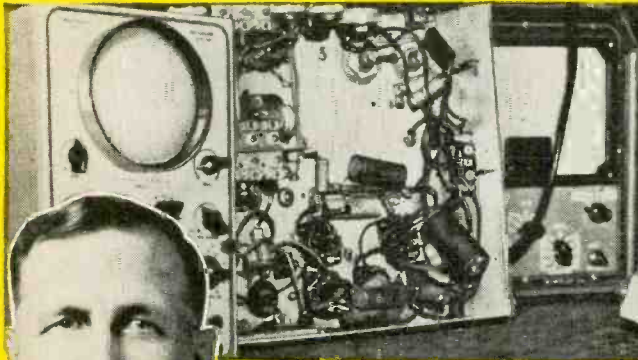

I WILL TRAIN YOU AT HOME IN SPARE TIME FOR SUCCESS IN RADIO-TELEVISION

Practice Broadcasting-Servicing with Equipment I Send

Nothing takes the place of PRACTICAL EXPERIENCE. That's why NRI training is based on LEARNING BY DOING. You use parts I send to build many circuits common to both Radio and Television. Mail coupon at the right. It will bring book of important facts. It shows you equipment you get and build for practical experience. All equipment I send is yours to keep.



Training PLUS opportunity is the PERFECT COMBINATION for job security, advancement. When times are good, the trained man makes the BETTER PAY, gets PROMOTED. When jobs are scarce, the trained man enjoys GREATER SECURITY. NRI training can help assure you and your family more of the better things of life. Radio is bigger than ever with over 3,000 broadcasting stations and more than 115 MILLION sets in use, and Television is moving ahead fast.

Start Soon to Make \$10, \$15 a Week Extra

My training is practical, complete; is backed by 40 years of success training men at home. My well-illustrated lessons give you basic principles you need and my skillfully developed kits of parts "bring to life" things you learn from the

lessons. I start sending you special booklets the day you enroll, that show you how to fix sets. Multitester you build helps you make money fixing neighbors' sets in spare time while training. Many make \$10, \$15 a week extra this way starting soon after they enroll.

Mail Coupon—Find Out What Radio-Television Offer You

Act now! I will send Actual Lesson to prove NRI home training is practical, thorough. My 64-page book "How to be a Success in Radio-Television" shows what my graduates are doing and earning. It gives important facts about your opportunities in Radio-Television. You can take NRI training for as little as \$5 a month. Mail coupon now to: J. E. SMITH, President, Dept. 4HF, National Radio Institute, Washington 9, D. C. Our 40th year.

I Trained These Men for Good Pay

Operator KPAT
"Am transmitter-studio operator at KPAT. Most important day of my life was when I enrolled with National Radio Institute." ELMER FREWALT, Madison, S. Dakota.

Technician TV Clinic
"Am employed as Technician for a TV Clinic, handling the tough jobs that cannot be fixed in the home. NRI started me off right." BERNARD SIERS, Cleveland, Ohio.

AVAILABLE TO
VETERANS
UNDER G. I. BILLS

Extra Money Spare Time
"Made \$100 from spare time work before I finished my course. Now average better than \$10 a week, spare time." FRANK BORER, Lorain, Ohio.



Good For Both—FREE

MR. J. E. SMITH, President, Dept. 4HF
National Radio Institute, Washington 9, D. C.

Mail me Sample Lesson and 64-page Book, FREE. (No salesman will call. Please write plainly.)

Name _____ Age _____
Address _____
City _____ Zone _____ State _____

VETS WRITE IN DATE OF DISCHARGE _____

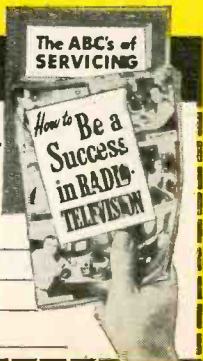

RADIO - ELECTRONICS

Formerly RADIO CRAFT • Incorporating SHORT WAVE CRAFT • TELEVISION NEWS • RADIO & TELEVISION*

Hugo Gernsback Editor and Publisher

M. Harvey Gernsback
Editorial Director

Fred Shunaman
Managing Editor

Robert F. Scott
W2PWG, Technical Editor

Jerome Kass
Associate Editor

J. Queen
Editorial Associate

Matthew Mandl
Television Consultant

Charles A. Phelps
Copy Editor

Angie Pascale
Editorial Production

Wm. Lyon McLaughlin
Tech. Illustration Director

Sol Ehrlich
Art Director

Lee Robinson
General Manager

John J. Lamson
Sales Manager

G. Aliquo
Circulation Manager

Adam J. Smith
Director, Newsstand Sales

Robert Fallath
Promotion Manager

Seymour Schwartz
Advertising Production



Member
Magazine Publishers
Association

ON THE COVER (Story on page 76)

Margaret Bagley, of the Bell Laboratories staff, operates the transmitter, which is modulated by a small phonograph. Power is furnished by an electric light bulb.

(Color original by Davis & Field)

CONTENTS

AUGUST 1954

Editorial (Page 29)			
Rocky Road to Success.....	by Hugo Gernsback	29	
Test Instruments (Pages 30-41)			
Junction Transistor Checker.....	by Edwin Bohr	30	
Improving the TV Alignment Generator.....	by Frank DiElsi	33	
Scope Frequency Compensation.....	by Elliott A. McCready	35	
High-Accuracy Ohmmeter.....	by Norman H. Crowhurst	36	
Miniature Audio-Frequency Test Oscillator.....	by J. Queen	38	
Distortion Totalizer.....	by C. W. Palmer	39	
Television (Pages 42-53)			
Tracking Down Horizontal Instability, Part I.....	by Cyrus Glickstein	42	
New Television Stations.....		44	
Color TV Circuits, Part III—Burst Amplifier, Color Oscillator and Control Circuits.....	by Ken Kleidon and Phil Steinberg	45	
Ghost Attenuator.....	by H. E. Warriner	47	
Television—it's a Cinch, (Twelfth conversation, first half: r.f. problems, visible noise, selectivity versus bandpass.....)	by E. Aisberg	48	
TV Service Clinic.....	Conducted by Matthew Mandl	51	
Rejection Filter for TV Buzz.....	by Irving Gottlieb	53	
Audio-High Fidelity (Pages 54-74)			
High-Quality Audio, Part XII—A popular "inverter", the cross-coupled amplifier.....	by Richard H. Dorf	54	
Servicing High-Fidelity Equipment, Part VI—Using oscilloscope patterns for analyzing and locating troubles.....	by Joseph Marshall	56	
High-Fidelity Loudspeakers, Part IV—The enclosure, cabinet or baffle can be a decisive factor.....	by H. A. Hartley	60	
High Fidelity for TV.....	by Stanley Rowson	62	
Low-Noise Transistor Preamplifier.....	by Rufus P. Turner	64	
Space Sound.....		69	
Sound Destroys Sound.....		70	
A Low-Cost Audio Amplifier.....	by G. Franklin Montgomery	72	
Electronics (Pages 76-78)			
Solar Battery Powers Transmitter (Cover Feature) by D. M. Chapin and D. E. Thomas.....		76	
Radio (Pages 80-88)			
Printed Circuit I.F.'s for Hi-Fi FM Tuners.....	by Robert Grodinsky	80	
Regenerative Transistor Receiver.....	by Dr. William G. Grace, Jr.	84	
Transistor Dot Maker.....		86	
Junction Transistors for High-Frequency Oscillator.....	by J. Queen	87	
New Design (Pages 92-95)			
New Tubes and Transistors.....		92	
Departments			
The Radio Month.....	6	Radio-Electronic Circuits.....	108
Correspondence.....	16	Try This One.....	110
Technotes.....	89	Business.....	112
Technicians' News.....	90	People.....	115
New Patents.....	96	Electronic Literature.....	118
New Devices.....	102	Book Reviews.....	120
Question Box.....	106		



MEMBER Audit Bureau of Circulations

Average Paid Circulation over 171,000

Vol. XXV, No. 8

RADIO-ELECTRONICS, August 1954, Vol. XXV, No. 8. Published monthly at Mt. Morris, Illinois by Gernsback Publications, Inc. Entered as Second Class matter June 23, 1954, at the Post Office at Mt. Morris, Ill. Copyright 1954 by Gernsback Publications, Inc. Text and Illustrations must not be reproduced without permission of copyright owners. EXECUTIVE, EDITORIAL and ADVERTISING OFFICES: Gernsback Publications, Inc., 25 West Broadway, New York 7, N. Y. Telephone REctor 2-8630. Hugo Gernsback, President; M. Harvey Gernsback, Vice-President; G. Aliquo, Secretary.

SUBSCRIPTIONS: Address correspondence to Radio-Electronics, Subscription Dept., 404 N. Wesley Ave., Mt. Morris, Ill., or 25 West Broadway, New York 7, N. Y. When ordering a change please furnish an address stencil impression from a recent wrapper. Allow one month for change of address.

SUBSCRIPTION RATES: In U. S. and Canada, and in U. S. possessions, \$3.50 for one year; \$6.00 for two years; \$8.00 for three years; single copies 35c. All other foreign countries \$4.50 a year; \$8.00 for two years; \$11.00 for three years.

BRANCH ADVERTISING OFFICES: Chicago: 7522 North Sheridan Road, Tel. Rogers Park 4-8000. Los Angeles: Ralph W. Harker and Associates, 1127 Wilshire Blvd., Tel. Madison 6-1271. San Francisco: Ralph W. Harker and Associates, 582 Market St., Tel. GARfield 1-2481. FOREIGN AGENTS: Great Britain: Atlas Publishing and Distributing Co., Ltd., London E.C. 4. Australia: McGill's Agency, Melbourne. France: Brentano's, Paris 2e. Belgium: Agence et Messageries de la Presse, Brussels. Holland: Trilectron, Heemstede. Greece: International Book & News Agency, Athens. So. Africa: Central News Agency Ltd., Johannesburg. Capetown, Durban, Natal. Universal Book Agency, Johannesburg. Middle East: Steimatzky Middle East Agency, Jerusalem. India: Broadway News Centre, Dadar, Bombay #14. Pakistan: Paradise Book Stall, Karachi 3. POSTMASTER: If undeliverable send form 3578 to: RADIO-ELECTRONICS, 25 West Broadway, New York 7, N. Y. *Trademark registered U.S. Patent Office.

ADVANCE! Raise your earning power—learn RADIO-TELEVISION-ELECTRONICS by SHOP-METHOD HOME TRAINING

GOOD JOBS AWAIT THE TRAINED RADIO-TV TECHNICIAN

There is a place for *you* in the great Radio-Television-Electronics industry when you are trained as National Schools will train you at home!

Trained technicians are in growing demand at good pay—in manufacturing, broadcasting, television, communications, radar, research laboratories, home Radio-TV service, and other branches of the field. National Schools Master Shop-Method Home Training, with newly added lessons and equipment, trains you in your spare time, right in your own home, for these fascinating opportunities. **OUR METHOD IS PROVED BY THE SUCCESS OF NATIONAL SCHOOLS TRAINED MEN, ALL OVER THE WORLD, SINCE 1905.**

EARN WHILE YOU LEARN

Many National students pay for all or part of their training with spare time earnings. We'll show you how you can do the same! Early in your training, you receive "Spare-time Work" Lessons which will enable you to earn extra money servicing neighbors' and friends' Radio and Television receivers, appliances, etc.



Signal Generator



T. R. F. Receiver

Audio Oscillator

National Schools Training is All-Embracing

National Schools prepares you for your choice of many job opportunities. Thousands of home, portable, and auto radios are being sold daily—more than ever before. Television is sweeping the country, too. Co-axial cables are now bringing Television to more cities, towns, and farms every day! National Schools' *complete* training program qualifies you in all fields. Read this partial list of opportunities for trained technicians:

Business of Your Own • Broadcasting
Radio Manufacturing, Sales, Service • Telecasting
Television Manufacturing, Sales, Service
Laboratories: Installation, Maintenance of Electronic Equipment
Electrolysis, Call Systems
Garages: Auto Radio Sales, Service
Sound Systems and Telephone Companies, Engineering Firms
Theatre Sound Systems, Police Radio
And scores of other good jobs in many related fields.

TELEVISION TRAINING

You get a complete series of up-to-the-minute lessons covering all phases of repairing, servicing and construction. The same lesson texts used by resident students in our modern and complete Television broadcast studios, laboratories and classrooms!



MASTER ALL PHASES!

Get Master Shop-Method Home Training from an Established Practical Resident School with its own Training — almost 50 Years of Successful Experience in Training Ambitious Men.

Shops, Laboratories, Studios — almost 50 Years of Successful Experience in Training Ambitious Men.

We Bring National Schools To You!

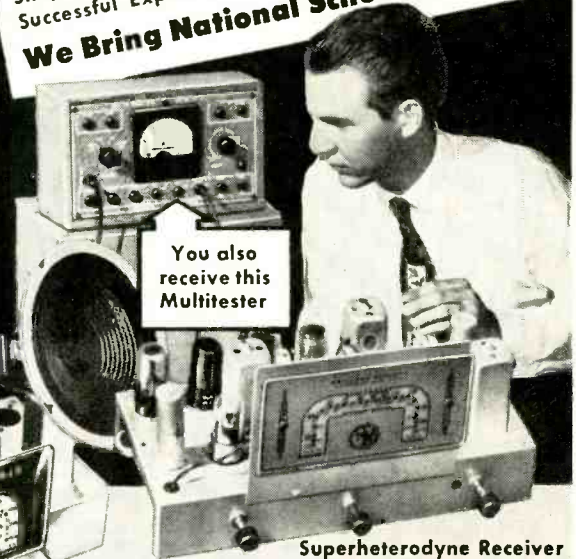

You also receive this Multitester

Superheterodyne Receiver

LEARN BY DOING

You receive and keep all the modern equipment shown above, including tubes and valuable, professional quality Multitester. *No extra charges.*

FREE! RADIO-TV BOOK AND SAMPLE LESSON!

Send today for National Schools' new, illustrated Book of Opportunity in Radio-Television-Electronics, and an actual Sample Lesson. **No cost—no obligation.** Use the coupon now—we'll answer by return airmail.

APPROVED FOR
VETERANS
AND
NON-VETERANS
Check coupon below

Both
Resident and
Home Study
Courses Offered!



NATIONAL SCHOOLS

LOS ANGELES 37, CALIFORNIA • ESTABLISHED 1905
IN CANADA: 811 W. HASTINGS STREET, VANCOUVER, B.C.

GET FACTS FASTEST! MAIL TO OFFICE NEAREST YOU!

(mail in envelope or paste on postal card)

NATIONAL SCHOOLS, Dept. RG-84

4000 S. Figueroa Street Los Angeles 37, Calif. or 323 West Polk Street Chicago 7, Ill.

Send FREE Radio-TV Electronics book and FREE sample lesson. No obligation, no salesman will call.

NAME _____ BIRTHDAY _____ 19 _____

ADDRESS _____

CITY _____ ZONE _____ STATE _____

Check here if interested in Resident School Training at Los Angeles. VETERANS: Give Date of Discharge

**NEW High Fidelity
INTEGRATED
3-WAY
TRIAxIAL
15" and 12"
REPRODUCERS**

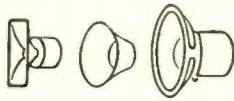

Concentrically
Combines E-V
Super-Sonax,
Radax Propagator,
and Bass Cone

**Brings advantage of distortion-free
wider range found in E-V separate
3-way systems, in one compact speaker**

E-V concentric Triaxial design gets the most from specialized driving media for each portion of the audio spectrum. Augmented bass response, full bodied mid-range and silky-smooth upper octaves to the highest audible frequencies provide excellent musical balance without masking effects or imposed distortions.

Model 12TRX. 12 $\frac{3}{16}$ " diam.

List, \$190 Audiophone Net, **\$114**

Model 15TRX. 15 $\frac{1}{8}$ " diam.

List, \$225 Audiophone Net, **\$135**

Includes X36-1 crossover network and AT37 brilliance control

- Response 30-15,000 cps in Recommended Enclosures
- Exclusive E-V Concentric Mounting Insures Full Range, Complete Room Coverage
- Balanced Response Characteristic Provides Realism and Presence
- Adjustable Brilliance Control for Remote Mounting. Allows Matching to Room Acoustics
- Edgewise Wound Voice Coil Design Affords 18% More Efficiency
- Full $\frac{1}{2}$ Section M-Derived Crossover Network Minimizes Distortion Products

Write for Bulletin No. 204

Electro-Voice
BUCHANAN, MICHIGAN

THE RADIO MONTH

DR. KARL T. COMPTON, physicist and educator, died June 22 at the age of 66, following a heart attack some days earlier.

Dr. Compton was the founder and head of the Radiation Laboratory of



the Massachusetts Institute of Technology. Later he became head of the Research and Development Board of the National Military Establishment, a position he held until medical reasons compelled him to abandon many of his activities in 1949. He remained chairman of M.I.T. till his death, however.

In addition to his research and organizational work in radar, communications, nuclear physics, guided missiles and other electronic applications, Dr. Compton was an advocate of broad education, and introduced a division of humanities at M.I.T. He received innumerable medals and awards, including the Congressional Medal of Merit for being "personally responsible for hastening the end of World War II", and 32 doctorates from institutions of learning in all parts of the world.

SELENIUM SHORTAGE has led to a salvage drive. Triggered by a letter from C. F. Honeywell, Administrator of the Business and Defense Services Administration of the Department of Commerce concerning the shortage of this highly strategic material since the Korean emergency, one large rectifier manufacturer has announced a system of purchasing burned out units.

The factory, according to the announcement, is already diverting factory-generated rejects for selenium reclamation. It is estimated that during the past 5 years 400,000 pounds of selenium have accumulated in out-of-warranty replaced rectifiers in the United States.

BASIC MEDIUM of communication in the United States is and will remain radio. This opinion was expressed by R. H. Hyde, acting chairman of the Federal Communications Commission in a speech at the recent NARTB convention.

Hyde said that on the basis of present grants and applications, there will be about 670 television stations in 325 communities. In contrast, 1,300 communities have their own local radio station.

The interest and attention devoted to television have obscured the continuing growth and development of aural broadcasting. In the past 10 months, 114 new AM station authorizations were issued, almost as many as new television grants.

FIVE NEW U. S. TV STATIONS have gone on the air since our last report. These are:

KFXJ-TV	Grand Junction, Colo.....	5
WDBO-TV	Orlando, Fla.....	6
KGLO-TV	Mason City, Ia.....	3
WBOC-TV	Salisbury, Md.....	16
KVDO-TV	Corpus Christi, Tex.....	22
WECT-TV,	Elmira, N. Y., channel 18,	has gone off the air.

Two new stations have gone on the air in Canada: CHCH-TV, Hamilton, Ontario, channel 11; CBWT, Winnipeg, channel 4.

A NEW DEPARTURE in electron tube manufacture, the "stacked tube" was revealed recently to a joint Armed Forces-industry-press conference by Sylvania Electric Products Inc.

The base of the new tube is a ceramic disc, through which the usual contact pins are brought. There are two additional rigid pins on which the elements are mounted. Holes in the anode and in the frame holding the grid assembly, and slips attached to the cathode, slip over the pins. Ceramic washers between the elements space them correctly. The pins are then

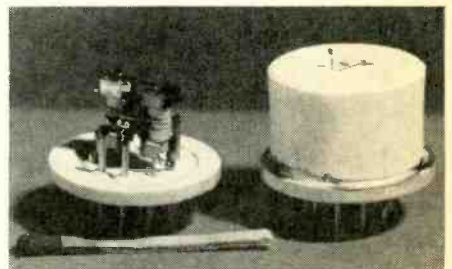

riveted down on the assembly and a ceramic cap sealed over the whole. The "stacked tube" will stand vibration, heat and shock that would destroy a standard glass tube of equivalent type.

CLINICAL THERMOMETER consisting of a tiny carboly thermistor mounted at the end of a stainless steel probe gives accurate readings in 5 to 7 seconds. Besides being quicker, speeding up the taking of temperatures 40 times, the new thermometer's probe is unbreakable, making it safer than the old glass type.

The probe is connected by a flexible transmission cord to a mercury cell, with a meter that registers the temperature. The thermistor resists heat and translates this resistance in terms of degrees on the meter.

The BACKSTOP

STOPS co-channel and adjacent-channel interference caused by rear signal pick-up!

- Highest front-to-back ratio ever built into an antenna!
- No rear pick-up; eliminates "venetian blinds"!
- Largest screen area: 70 square feet!
- Very high all-channel gain. Incorporates basic Champion design, including Tri-Pole, with additional elements!
- Completely preassembled!

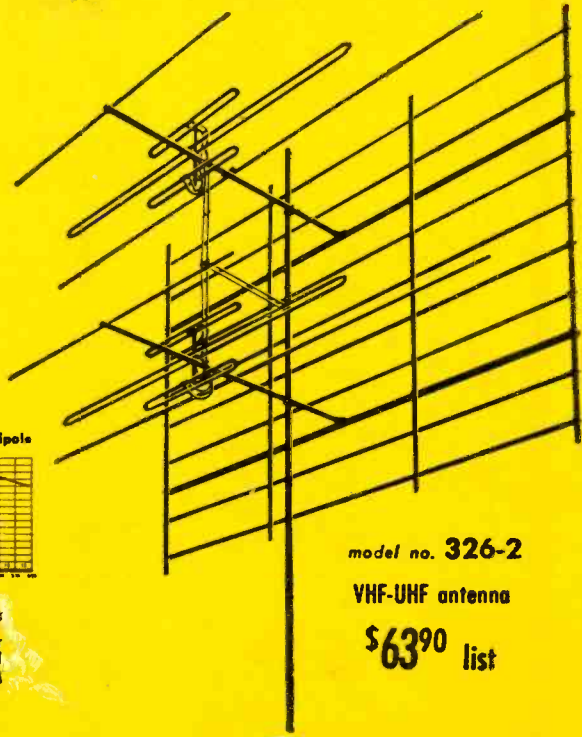
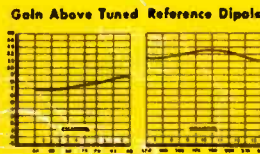
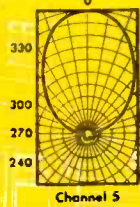

Table of Front-to-Back Ratios (Relative Voltage)

Channels	Front-to-Back Ratios
2	9:1
3	10:1
4	11:1
5	20:1
6	18:1

Only Low Band channels shown, since co-channel interference is not encountered on High Band channels.



IMPORTANT . . . don't be misled by polar patterns representing relative POWER. Remember, power is the square of voltage. All Channel Master polar patterns are presented in relative VOLTAGE.

model no. 326-2

VHF-UHF antenna

\$6390 list

2 radical new antennas by CHANNEL MASTER

The most beautiful antenna ever made! The only indoor antenna featuring powerful outdoor design principles — Bow-Tie and Screen.

Wonder Bow

* VHF-UHF indoor antenna

DESIGNED FOR POWER!

On **UHF**: For primary and secondary areas. In many cases, performance is equal to actual outdoor installations. Good directivity on all channels.

On **VHF**: Ideal in areas of strong VHF signals.

STYLED FOR BEAUTY!

Designed by a well-known industrial designer, the WONDER BOW is proof that indoor antennas can be beautiful as well as powerful. Wins customer approval on beauty alone!

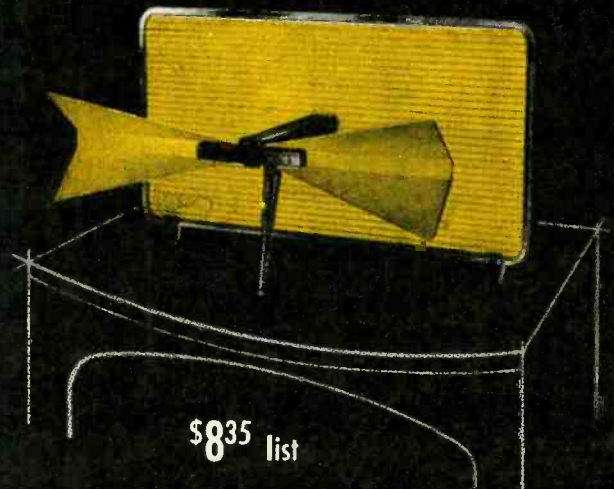

\$835 list

The first gain figures ever to be published for an indoor antenna!

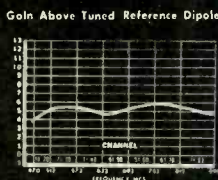

Gold and black
model no. 416

Silver and black
model no. 417



CHANNEL MASTER CORP. ELLENVILLE, N. C.

The World's Largest Manufacturer of TV Antennas

Write for complete technical literature.

Copyright 1954, Channel Master Corp.

*Pat. No. D-171560

Quality Features OF **TUNG-SOL** PICTURE TUBES

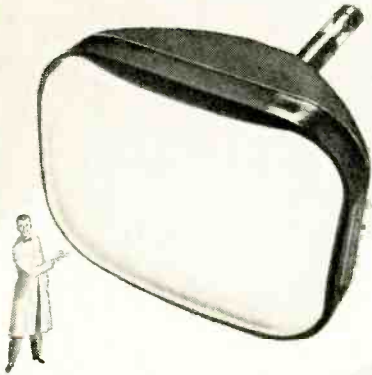

Gun made of best grade non-magnetic steel.

Glass bead type assembly is stronger both mechanically and electrically—gives greater protection against electrical leakage.

Rolled edges in gun minimize corona.

Custom built stem with greater spacing between leads assures minimum leakage.

Low resistance of outside conductive coating minimizes radiation of horizontal oscillator sweep frequency.

Double cathode tab provides double protection against cathode circuit failure.

Selected screen composition resists burning (X pattern).

Rigid control of internal conductive coating provides utmost service reliability.

Designed for use with single or double field ion trap designs.

One-piece construction of parts assures better alignment.

Maximum dispersion of screen coating assures uniform screen distribution.

Tung-Sol makes All-Glass Sealed Beam Lamps, Miniature Lamps, Signal Flashers, Picture Tubes, Radio, TV and Special Purpose Electron Tubes and Semiconductor Products.

TUNG-SOL ELECTRIC INC., Newark 4, N. J. Sales Offices: Atlanta, Chicago, Columbus, Culver City (Los Angeles), Dallas, Denver, Detroit, Newark, Seattle.

TUNG-SOL®

RADIO AND TV TUBES



You Can Build A Reputation On Tung-Sol Quality

THE RADIO MONTH

MAGNETIC TAPE has replaced disc records in the nationwide franchise service of one of the largest "background music" concerns. The company, Muzak Corporation, developed its own playback unit for the purpose and states that it will make the service cheaper and improve the quality of the music. It will make background music service economically possible in smaller communities that could not have been served with the disc system, the company states.

The new tape plays a full eight hours, running four hours in one direction, stopping and reversing automatically, and playing the additional four in the other direction. Subsonic signals on the tape control the starting and stopping, preselect specialized music (such as Christmas carols) when desired, rewind, or shut off the machine and switch in a companion. Two machines can play indefinitely and automatically. The only attention necessary is one visit a day to change reels.

SOLAR GENERATOR using cadmium sulphide instead of silicon as its light-sensitive element has been announced by the Wright Air Development Center of the Air Research and Development Command. Cadmium sulphide is best known as a yellow powder used as a paint pigment. As a converter of solar energy, it appears in crystal form.

The crystal in the first model is the size of a sugar cube, but wafer-thin crystals would work efficiently. The electrode attached to the sides of the crystal are of dissimilar metals. The negative electrode is indium and the positive, silver. Small motors and an electric clock have been operated by the experimental generator.

Larger units could be constructed,

and it is believed that a thin crystal slab with an area of 60 square feet, resting on or built into the roof of a house, could supply all its electrical requirements.

RADIO INTERFERENCE caused by high-voltage transmission lines in Sweden has been reduced successfully by transmitting radio programs over the power line itself. In the initial tests, a 250-watt transmitter operating at 182 kc was used.

The system consists of connecting a radio transmitter to the power line between one phase and ground via a capacitor conveniently located in the line system. The transmitter power is such that the signal level exceeds the interference level by an amount that makes the disturbance practically inaudible.

Radio noise interference had increased considerably when the 230-kv power system was extended to 400 kv. Attempts to reduce the difficulty by conventional methods—moving the antenna cable, shielding transverse lines, etc.—were unsuccessful. Radio reception is obtained in the usual manner by tuning the receiver to the wave length of the line radio. No special arrangements or equipment are required.

ULTRASONIC SOUNDS are produced by animals other than bats and porpoises. Dr. John W. Anderson of Cornell University has discovered that laboratory rats, guinea pigs and several other animals are also capable of producing inaudible sounds.

Dr. Anderson thinks the high-frequency sounds may serve for communication between individuals. Whether or not rodents use these for orientation as bats do is not known, but is not considered likely. **END**



Donald C. Reynolds (left) and Lt. Colonel Gerard M. Leies observe the solar generator as it turns small direct-current motor at 73 revolutions per minute.

All Electronic Parts
YOURS TO KEEP!

Now!
Work over
300
practical projects
WITH THESE
PARTS...



MULTIMETER

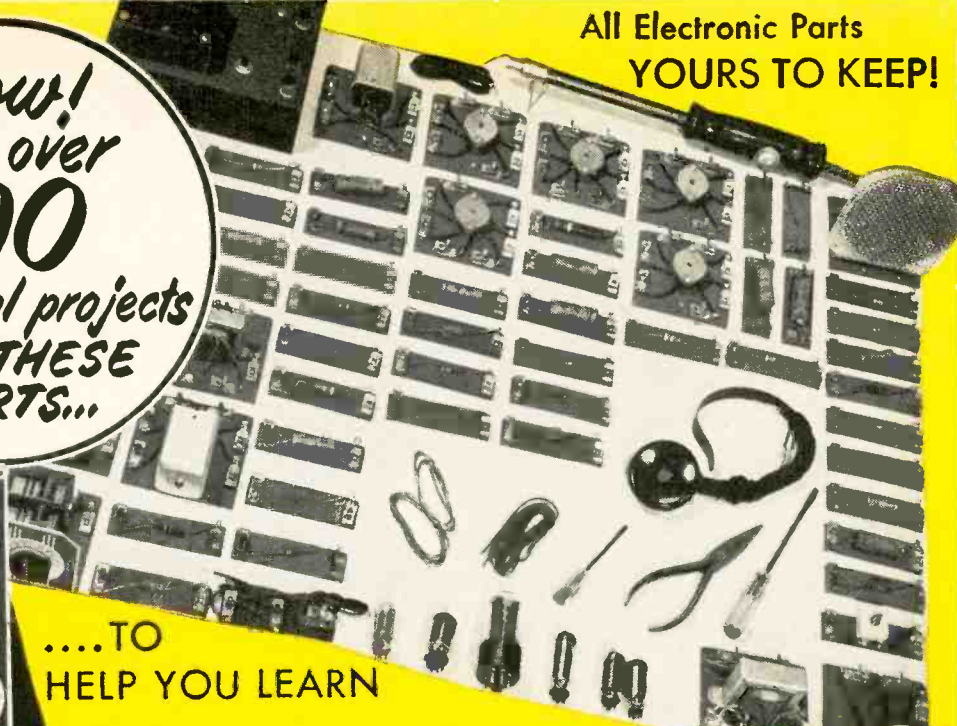

....TO
HELP YOU LEARN

TELEVISION

RADIO-ELECTRONICS Now ... at home in spare time you can get BOTH the very training and subsequent Employment Service you need to help you start earning real money in America's thrilling, multi-billion dollar opportunity field of Television-Radio-Electronics. Now that Television is coming to almost every community, here is a chance of a lifetime to prepare to cash in on one of Television's great expansions.

D.T.I.'s amazingly practical home method enables you to set up your own HOME LABORATORY. You get many Electronic parts which you mount on individual bases with spring clip connectors. Tops for experimenting! Add or remove parts in a jiffy. No wasted hours of soldering and unsoldering for each project. You spend minimum time to get maximum knowledge of important circuits that really work. In fact, you get exactly the same type of basic training equipment used in our Chicago training laboratory—one of the nation's finest.

Build and KEEP This VALUABLE TEST EQUIPMENT

Your home laboratory projects also include building and keeping a versatile 5 inch Oscilloscope and precision Jewel Bearing Multi-Meter. These quality commercial test instruments help you EARN WHILE YOU LEARN and will prove mighty valuable, should you later decide to start your own full time TV-Radio service business. You also build and keep a quality 21 inch TV SET.

D.T.I. Provides EVERYTHING YOU NEED to master TELEVISION

In addition to your home laboratory and easy-to-read lessons, you even use HOME MOVIES—a wonderfully effective and exclusive D.T.I. training advantage. You watch hidden actions... see electrons on the march. Important fundamentals... become "movie clear," helping you learn faster... easier... better.

Full time Residential training in D.T.I.'s great Chicago laboratories also available. MAIL COUPON TODAY for all facts. (If subject to Military Service, you'll especially welcome the information we have for you.)

D.T.I.'s Training is available in Canada



HOME MOVIES

89 WAYS TO EARN MONEY

MAIL COUPON TODAY!



5 INCH
"SCOPE"



21 INCH

Build and keep this BIG DTI Engineered TV set—easily converted to U.H.F. (DTI offers another home training, but without the TV set.)

"ONE OF AMERICA'S FOREMOST TELEVISION TRAINING CENTERS"

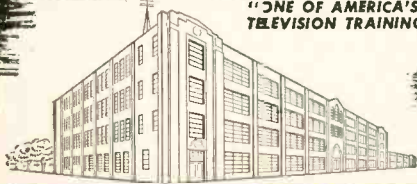

DeVRY TECHNICAL INSTITUTE

AFFILIATED WITH
DeFOREST'S TRAINING, INC.
CHICAGO 41, ILLINOIS

DeVRY TECHNICAL INSTITUTE

4141 BELMONT AVE., CHICAGO 41, ILL. DEPT. RE-8-K

I would like your valuable information-packed publication showing how I can get started toward a good job or my own business in Television-Radio-Electronics.

Name _____ Age _____

Street _____ Apt. _____

City _____ Zone _____ State _____



offers

50

SALES AND SHOP AIDS

to help YOU make more money!

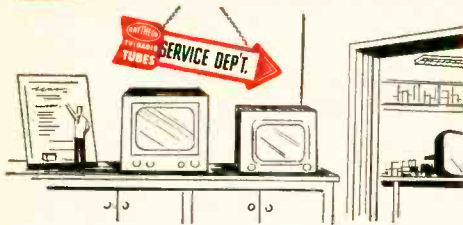

ILLUMINATED "SERVICE DEP'T" SIGN

Dress up your shop with this easy-to-hang direction sign. Supplied ready to hang.



TUBE and TOOL CARRYING CASE

Holds 137 tubes and necessary repair tools — all tubes are in full view.



RAYTHEON ConverTV Seats

Ideal for shop or home use, or as incentive gifts on TV set sales.

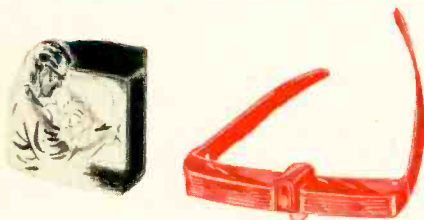

RAYTHEON BROWLITE

A new kind of flashlight that frees both hands for service work.



ILLUMINATED OUTDOOR SIGN

Double sided, — formed plastic face sign for outdoor use. 36" x 24". A real traffic stopper.



PRESSURE-SENSITIVE REPAIR STICKERS

Stick to any surface without moistening. Packaged in handy dispenser box.

OUTDOOR THERMOMETER

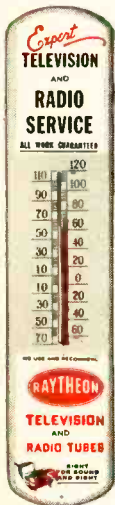

COLOR SPOT SIGNS

A brand new set of transparent window signs every service shop needs.



TRANSPARENT PLASTIC WINDOW STREAMER

TUBE SHELF IDENTIFICATION LABELS BOOK



Labels for over 480 current Raytheon Radio and TV tube type designations. Easy to apply.



WINDOW DISPLAYS

Bright, full color displays to sell your service. Both are varnished and easled.



They're all in this FREE BOOKLET! It's yours for the asking

You'll find many more money-making sales stimulators and time-saving shop aids in this booklet — all designed to help you make more money by increasing service business and saving valuable time. Many are free and others are made available through your Raytheon Tube Distributor at less than cost. To get a copy of the booklet write to Raytheon Manufacturing Company, Receiving and Cathode Ray Tube Operations, 55 Chapel Street, Newton 58, Mass. Department



RAYTHEON MANUFACTURING COMPANY

Receiving and Cathode Ray Tube Operations
Newton, Mass., Chicago, Ill., Atlanta, Ga., Los Angeles, Calif.

Excellence in Electronics

RAYTHEON MAKES ALL THESE:

RECEIVING AND PICTURE TUBES, RELIABLE SUBMINIATURE AND MINIATURE TUBES, SEMICONDUCTOR DIODES AND TRANSISTORS, NUCLEONIC TUBES, MICROWAVE TUBES

Which Do You Want?

\$ PAY CHECK

Better Pay



A Nice Home



Greater Security



A New Car



Happy Vacation and Travel

Get Your FCC Ticket
-Then Use Our
Amazingly Effective
Job-Finding Service
To Get a Better Job

add technical training to your practical experience and

**Get Your
COMMERCIAL
FCC RADIO OPERATOR
LICENSE
IN A MINIMUM OF TIME!**



I can train you to pass your FCC License Exams in a minimum of time if you've had any practical radio experience—amateur, Army, Navy, radio servicing or other. My time-proven plan can help put you, too, on the road to success.

Let me send you FREE the entire story Just fill out the coupon and mail it. I will send you, free of charge a copy of "How to Pass FCC License Exams," plus a sample FCC-type Exam, and the amazing new booklet, "Money Making FCC License Information."

Carl E. Smith, E.E.
President

Get This
Amazing Booklet
FREE...



TV ENGINEERING
INCLUDED IN OUR
TRAINING AND
COACHING

TELLS HOW

HERE IS YOUR GUARANTEE
If you fail to pass your Commercial License exam after completing our course, we guarantee to continue your training without additional cost of any kind, until you successfully obtain your Commercial License, provided you first sit for this examination within 90 days after completing your course.

WE GUARANTEE
TO TRAIN AND COACH YOU AT HOME IN SPARE TIME
UNTIL YOU GET **YOUR FCC LICENSE**

TELLS HOW Employers Make
JOB OFFERS Like These to Our
Graduates Every Month

Letter from nationally-known Airlines, "We would also appreciate if you would place the following additional advertisement in your bulletin—Wanted—Superintendent of Communications..... Salary \$668.66 per month.
Letter from nationally-known Airlines, "We are contemplating placing..... an Airline Ground Radio Engineer." Starting salary \$385 per month.
These are just a few examples of the job offers that come to our office periodically. Some licensed radioman filled each of these jobs... It might have been you!

**HERE'S PROOF FCC LICENSES ARE OFTEN SECURED
IN A FEW HOURS OF STUDY WITH OUR
Coaching AT HOME in Spare Time**

Name and Address	License	2nd Phone	Lessons
Lee Worthy 2210 1/2 Wilshire St., Bakersfield, Cal.	16
Clifford E. Vogt Box 1016, Dania, Fla.	1st Phone	20
Francis X. Foerch 38 Beucier Pl., Bergenfield, N. J.	1st Phone	38

CLEVELAND INSTITUTE OF RADIO ELECTRONICS
Desk RE-67, 4900 Euclid Bldg., Cleveland 3, Ohio
CARL E. SMITH, E.E., Consulting Engineer, Pres.

TELLS HOW

**Our Amazingly Effective JOB-FINDING SERVICE
Helps CIRE Students Get Better Jobs**
Here is just one recent example of Job-Finding Results
Gets Five Job-Offer from Broadcast Stations

**OURS IS THE ONLY
HOME STUDY
COURSE WHICH
SUPPLIES FCC-
TYPE EXAMINA-
TIONS WITH ALL
LESSONS AND
FINAL TESTS.**

"Your 'Chief Engineer's Bulletin' is a grand way of obtaining employment for your graduates who have obtained their 1st class license. Since my name has been on the list, I have received calls or letters from five stations in the southern states, and am now employed as Transmitter Engineer at WMMT."
Elmer Powell, Box 274, Sparta, Tenn.

Your FCC ticket is recognized by employers in the electronic field as proof of your technical ability.

Get All 3 Free
MAIL
COUPON
NOW



B Cleveland Institute of Radio Electronics
Desk RE-67, 4900 Euclid Bldg., Cleveland 3, Ohio
(Address to Desk No. to avoid delay)

I want to know how I can get my FCC ticket in a minimum of time. Send me your FREE booklet, "How to Pass FCC License Examinations" (does not cover exams for Amateur License), as well as a sample FCC-type exam and the amazing new booklet, "Money-Making FCC License Information." Be sure to tell me about your Television Engineering Course.

Name
Address
City Zone State

Paste on 2-cent postcard or send airmail.

When It's Designed and Built
by BLONDER-TONGUE...

There's a BIG Difference



B-T LABS UHF
Converter
MODEL "99" \$19.95
LIST

...and
for **ULTRA PERFORMANCE**

THE **B-T LABS** *Ultravert*
Model BTU-2



at \$39.95
LIST

still leads every other unit in the field,
regardless of price, because of:

- Higher Gain
- Precise Impedance Match
- Automatic 'on/off'
- Lower Noise Factor
- Dual Speed Tuning
- Exclusive B-T Ultratuner

When B-T designs and builds an all-channel UHF converter to sell for less than \$20.00, you can be sure that it will outperform any other converter in its class...at least 4 ways:

1. **TUNED INPUT**—Tracks with oscillator—Rejects spurious signals—Suppresses oscillator radiation.
2. **PRECISE IMPEDANCE MATCH**—Maximum signal conversion—No line ghosts—No picture smear.
3. **ONE-KNOB TUNING**—No VHF channel switching.
4. **DRIFT-FREE PERFORMANCE**—Thermally compensated oscillator circuit.



Check with your supplier today...or write to Dept. TH-3
BLONDER-TONGUE LABORATORIES, INC.
WESTFIELD, NEW JERSEY

Manufacturers of TV Amplifiers, Boosters, Accessories, and Originators of the
B-T 'Add-A-Unit' Master TV System.

Quick TV Success can be yours

if you act now!

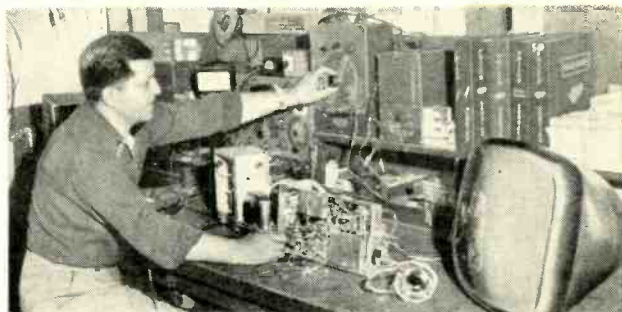
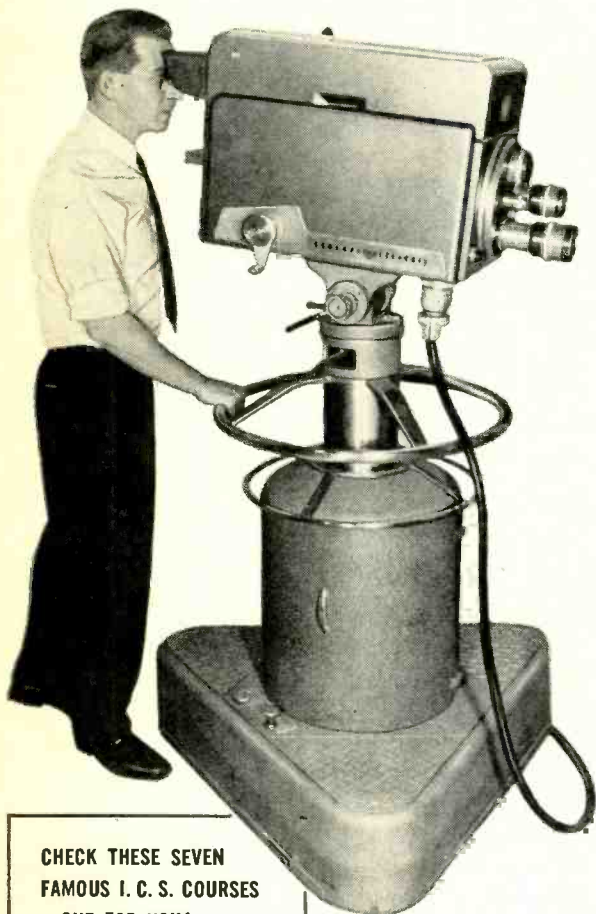

- Prepare now for the new Radio-TV-Electronics boom. Get in on VHF and UHF . . . aviation and mobile radio . . . color TV . . . binaural sound! The International Correspondence Schools can help you!

If you've ever thought about Radio or Television as a career . . . if you have the interest, but not the training . . . if you're waiting for a good time to start . . . NOW'S THE TIME!

No matter what your previous background, I.C.S. can help you. If Radio-TV servicing is your hobby, I.C.S. can make it your own profitable business. If you're interested in the new developments in Electronics, I.C.S. can give you the basic courses of training you need. If you have the job but want faster progress, I.C.S. can qualify you for promotions and pay raises.

I.C.S. training is *success-proved* training. Hundreds of I.C.S. graduates hold top jobs with top firms like R.C.A., G.E., DUMONT, I.T.&T. Hundreds of others have high ratings in military and civil service. Still others have successful businesses of their own.

With I.C.S., you get the rock-bottom basics and theory as well as the all-important bench practice and experimentation. You learn in your spare time—no interference with business or social life. You set your own pace—progress as rapidly as you wish.

Free career guidance: Send today for the two free success books, the 36-page "How to Succeed" and the informative catalog on the course you check below. No obligation. Just mark and mail the coupon. With so much at stake, you owe it to yourself to act—and act fast!

CHECK THESE SEVEN FAMOUS I. C. S. COURSES — ONE FOR YOU!

- PRACTICAL RADIO-TELEVISION ENGINEERING**—Foundation course for radio-television career. Basic principles plus advanced training. Radio, Sound, TV.
- TELEVISION TECHNICIAN**—To qualify you for high-level technical positions in television. Camera, studio, transmitter techniques. Manufacture, sale and installation of TV equipment.
- TELEVISION RECEIVER SERVICING**—Installation, servicing, conversion. Dealership. For the man who knows about radio and wants TV training.
- RADIO & TELEVISION SERVICING**—Designed to start you repairing, installing and servicing radio and television receivers soon after starting the course.
- RADIO & TELEVISION SERVICING WITH TRAINING EQUIPMENT**—Same as above but with addition of high-grade radio servicing equipment and tools.
- RADIO OPERATING COURSE**—Special course to help you pass the Government examination for operator's licenses. Code. TV. FM. Radio regulations.
- INDUSTRIAL ELECTRONICS**—Broad, solid background course devoted to the electron tube and to its many applications.

INTERNATIONAL CORRESPONDENCE SCHOOLS



BOX 2878-L, SCRANTON 9, PENNA.

Without cost or obligation, send me "HOW TO SUCCEED" and the booklet about the course BEFORE which I have marked X:

- | | | | | |
|--|---|---|---|---|
| <p>ART</p> <ul style="list-style-type: none"> <input type="checkbox"/> Commercial Art <input type="checkbox"/> Magazine Illustrating <input type="checkbox"/> Fashion Illustrating <input type="checkbox"/> Cartooning <input type="checkbox"/> Sketching and Painting <input type="checkbox"/> Show Card and Sign Lettering <p>AUTOMOTIVE</p> <ul style="list-style-type: none"> <input type="checkbox"/> Automobile, Mechanic <input type="checkbox"/> Auto Elec. Technician <input type="checkbox"/> Auto Body Rebuilding and Refinishing <input type="checkbox"/> Diesel—Gas Engines <p>AVIATION</p> <ul style="list-style-type: none"> <input type="checkbox"/> Aeronautical Engineering Jr. <input type="checkbox"/> Aircraft Engine Mechanic <input type="checkbox"/> Airplane Drafting <p>BUILDING</p> <ul style="list-style-type: none"> <input type="checkbox"/> Architecture <input type="checkbox"/> Arch. Drafting <input type="checkbox"/> Building Contractor <input type="checkbox"/> Estimating <input type="checkbox"/> Carpenter and Mill Work <input type="checkbox"/> Carpenter Foreman <input type="checkbox"/> Reading Blueprints <input type="checkbox"/> House Planning <input type="checkbox"/> Plumbing | <p>HEATING</p> <ul style="list-style-type: none"> <input type="checkbox"/> Heating <input type="checkbox"/> Painting Contractor <input type="checkbox"/> Air Conditioning <input type="checkbox"/> Electrician <p>BUSINESS</p> <ul style="list-style-type: none"> <input type="checkbox"/> Business Administration <input type="checkbox"/> Certified Public Accountant <input type="checkbox"/> Bookkeeping and Accounting <input type="checkbox"/> Office Management <input type="checkbox"/> Stenography and Typing <input type="checkbox"/> Secretarial <input type="checkbox"/> Federal Tax <input type="checkbox"/> Business Correspondence <input type="checkbox"/> Letter-writing Improvement <input type="checkbox"/> Personnel and Labor Relations <input type="checkbox"/> Advertising <input type="checkbox"/> Retail Business Management <input type="checkbox"/> Managing Small Business <input type="checkbox"/> Ocean Navigation <input type="checkbox"/> Sales Management <input type="checkbox"/> Short Story Writing <input type="checkbox"/> Creative Salesmanship <input type="checkbox"/> Traffic Management <p>CHEMISTRY</p> <ul style="list-style-type: none"> <input type="checkbox"/> Chemical Engineering <input type="checkbox"/> Chemistry <input type="checkbox"/> Analytical Chemistry | <p>PETROLEUM—NAT'L GAS</p> <ul style="list-style-type: none"> <input type="checkbox"/> Pulp and Paper Making <input type="checkbox"/> Plastics <p>CIVIL STRUCTURAL ENGINEERING</p> <ul style="list-style-type: none"> <input type="checkbox"/> Civil Engineering <input type="checkbox"/> Structural Engineering <input type="checkbox"/> Surveying and Mapping <input type="checkbox"/> Structural Drafting <input type="checkbox"/> Highway Engineering <input type="checkbox"/> Reading Blueprints <input type="checkbox"/> Construction Engineering <input type="checkbox"/> Sanitary Engineering <p>DRAFTING</p> <ul style="list-style-type: none"> <input type="checkbox"/> Aircraft Drafting <input type="checkbox"/> Architectural Drafting <input type="checkbox"/> Electrical Drafting <input type="checkbox"/> Mechanical Drafting <input type="checkbox"/> Structural Drafting <input type="checkbox"/> Sheet Metal Drafting <input type="checkbox"/> Ship Drafting <input type="checkbox"/> Mine Surveying and Drafting <p>ELECTRICAL</p> <ul style="list-style-type: none"> <input type="checkbox"/> Electrical Engineering <input type="checkbox"/> Electrician <input type="checkbox"/> Electrical Maintenance | <p>ELECTRICAL DRAFTING</p> <ul style="list-style-type: none"> <input type="checkbox"/> Electrical Power and Light <input type="checkbox"/> Lineman <p>HIGH SCHOOL</p> <ul style="list-style-type: none"> <input type="checkbox"/> High School Subjects <input type="checkbox"/> Mathematics <input type="checkbox"/> Commercial <input type="checkbox"/> Good English <p>MECHANICAL AND SHOP</p> <ul style="list-style-type: none"> <input type="checkbox"/> Mechanical Engineering <input type="checkbox"/> Industrial Engineering <input type="checkbox"/> Industrial Supervision <input type="checkbox"/> Foremanship <input type="checkbox"/> Mechanical Drafting <input type="checkbox"/> Machine Design-Drafting <input type="checkbox"/> Machine Shop Practice <input type="checkbox"/> Tool Design <input type="checkbox"/> Industrial Instrumentation <input type="checkbox"/> Machine Shop Inspection <input type="checkbox"/> Reading Blueprints <input type="checkbox"/> Toolmaking <input type="checkbox"/> Gas—Electric Welding <input type="checkbox"/> Heat Treatment—Metallurgy <input type="checkbox"/> Sheet Metal Work <input type="checkbox"/> Sheet Metal Pattern Drafting <input type="checkbox"/> Refrigeration | <p>POWER</p> <ul style="list-style-type: none"> <input type="checkbox"/> Combustion Engineering <input type="checkbox"/> Diesel—Electric <input type="checkbox"/> Electric Light and Power <input type="checkbox"/> Stationary Steam Engineering <input type="checkbox"/> Stationary Fireman <p>RADIO, TELEVISION COMMUNICATIONS</p> <ul style="list-style-type: none"> <input type="checkbox"/> Practical Radio—TV Eng'ing <input type="checkbox"/> Radio Operating <input type="checkbox"/> Radio and TV Servicing <input type="checkbox"/> Television—Technician <input type="checkbox"/> Electronics <input type="checkbox"/> Telephone Work <p>RAILROAD</p> <ul style="list-style-type: none"> <input type="checkbox"/> Locomotive Engineer <input type="checkbox"/> Diesel Locomotive <input type="checkbox"/> Air Brakes <input type="checkbox"/> Car Inspector <input type="checkbox"/> Railroad Administration <p>TEXTILE</p> <ul style="list-style-type: none"> <input type="checkbox"/> Textile Engineering <input type="checkbox"/> Cotton, Rayon, Woolen Mfg. <input type="checkbox"/> Carding and Spinning <input type="checkbox"/> Warping and Weaving <input type="checkbox"/> Loom Fixing <input type="checkbox"/> Throwing <input type="checkbox"/> Finishing and Dyeing <input type="checkbox"/> Textile Designing |
|--|---|---|---|---|

Name _____ Age _____ Home Address _____

City _____ Zone _____ State _____ Working Hours _____ A.M. to P.M. _____

Occupation _____

Canadian residents send coupon to International Correspondence Schools Canadian, Ltd., Montreal, Canada. . . . Special tuition rates to members of the U. S. Armed Forces.

Exclusive!
**Electro-Lens
 Focusing*!**

get sharper...
MUCH SHARPER...
 pictures

Give your customers the most sparkling pictures they've ever hoped for . . . pictures with all the dramatic highlights and tones of a portrait photograph . . . with the revolutionary new Winegard Interceptor TV Antenna! Restores vibrant life to the dull, blurred image of many old sets . . . brings out every last ounce of performance in the newest.

For only the Interceptor has that amazing "Electro-Lens Focusing" . . . the patented design that pulls in all the signal . . . actually builds up its intensity . . . then focuses the amplified signal to the screen, much as an

optical lens focuses and intensifies light rays.

And—the Interceptor gives maximum rejection of side and back interference . . . vastly superior reception in outlying areas. Particularly suited to color TV, designed to give performance unmatched by any other antenna on all VHF channels. Lightweight, compact, wind resistant.

An obsolete antenna can make even the finest set unsatisfactory. So give your customers the best performance from any set, old or new . . . insure their utmost satisfaction. Write for complete information about the Winegard Interceptor Antenna today!

*Patent Pending



WINEGARD *Interceptor* ANTENNA

with Exclusive Electro-Lens Focusing

WINEGARD COMPANY, 3000 Scotten Boulevard, Burlington, Iowa

Home Study Courses in TELEVISION SERVICING offered by RCA INSTITUTES

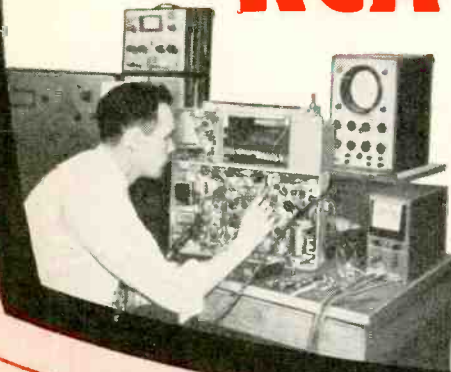

Study Television Servicing—from the very source of the latest, up-to-the-minute TV and Color TV developments. Train under the direction of men who are experts in this field. Take advantage of this opportunity to place yourself on the road to success in television. RCA Institutes, Inc. (A Service of Radio Corporation of America), thoroughly trains you in the "why" as well as the "how" of servicing television receivers.

FIRST HOME STUDY COURSE IN COLOR TV SERVICING

Now you can train yourself to take advantage of the big future in Color TV. RCA Institutes Home Study Course covers all phases of Color TV Servicing. It is a practical down-to-earth course in basic color theory as well as how-to-do-it servicing techniques.

This color television course was planned and developed through the combined efforts of instructors of RCA Institutes, engineers of RCA Laboratories, and training specialists of RCA Service Company. You get the benefit of years of RCA research and development in color television.

Because of its highly specialized nature, this course is offered only to those already experienced in radio-television servicing. Color TV Servicing will open the door to the big opportunity you've always hoped for. Find out how easy it is to cash in on Color TV. *Mail coupon today.*

SEND FOR FREE BOOKLET

Mail coupon in envelope or paste on postal card. Check course you are interested in. We will send you a booklet that gives you complete information. No salesman will call.



RCA INSTITUTES, INC.
A SERVICE OF RADIO CORPORATION of AMERICA
350 WEST FOURTH STREET, NEW YORK 14, N. Y.

HOME STUDY COURSE IN BLACK-AND-WHITE TV SERVICING

Thousands of men in the radio-electronics industry have successfully trained themselves as qualified specialists for a good job or a business of their own—servicing television receivers. You can do this too.

This RCA Institutes TV Servicing course gives you up-to-the-minute training and information on the very latest developments in black-and-white television.

As you study at home, in your spare time, you progress rapidly. Hundreds of pictures and diagrams, easy-to-understand lessons help you to quickly become a qualified TV serviceman.

There are ample opportunities in TV, for radio servicemen who have expert training. Mail coupon today. Start on the road to success in TV Servicing.

MAIL COUPON NOW

RCA INSTITUTES, INC.
Home Study Dept. RE-854
350 West Fourth Street, New York 14, N. Y.
Without obligation on my part, please send me copy of booklet on:

- Home Study Course in TELEVISION SERVICING.
 Home Study Course in COLOR TV SERVICING.

Name _____ (please print)
Address _____
City _____ Zone _____ State _____

3 SHURE CRYSTAL PICKUP CARTRIDGES replace the 192

cartridges you are most likely to encounter in your service work!



TECHNICAL DATA AND REPLACEMENT CHART IS ENCLOSED.

MODEL RK-54
Replacement Kit
List Price \$22.55

Lists 192 Crystal Cartridges manufactured by five leading cartridge manufacturers.

Lowest investment for broadest coverage! The RK-54 is beyond all doubt the most practical Replacement Kit on the market! Proof? Simply this—you get the broadest coverage at the lowest investment—only \$22.55 list! Think of it—3 Crystal Cartridges replace 192 of those specific Cartridges most likely to be in need of replacement! Two of the Cartridges consistently have been “best sellers” in the Shure line—as established by actual sales to Servicemen! The Cartridges are: Model W22AB, 3-Speed, 2-Needle Cartridge—Model W26B, All-Purpose, Single-Needle Cartridge—Model W78, 78 RPM, Dual-Volt, Dual-Weight Cartridge. Model W78 is the new, versatile Cartridge that replaces 149 other Cartridges. This Cartridge alone will become a sensation overnight! Order a Replacement Kit from your Distributor today—once you have worked with this practical kit you will find that these three Cartridges are dependable replacements—will make your service work faster, easier and more profitable!



TRANSPARENT PLASTIC BOX IS FREE!

This Handy Box is 5" long, 3½" wide, 1¼" deep.

SHURE

The Mark of Quality

CORRESPONDENCE

ELECTRONIC COMPLEXITY

Dear Hugo:

I read with great interest and approval your editorial in the June issue of RADIO-ELECTRONICS. I think you have there offered a very practical solution to the ever-increasing complexity of television receiver and computer circuits, with their accompanying increasing liabilities to contact interruptions.

Unquestionably the idea of wrapping up the circuits in a relatively small number of compact packages would prove such a practical and economical solution that it would be widely accepted throughout the electronic industry.

I never fail to read your monthly editorials and inevitably find them interesting and suggestive.

LEE DE FOREST

Los Angeles, Calif.

ORCHIDS TO US

Dear Editor:

This is a note I've been intending to write each time I see a new issue of RADIO-ELECTRONICS. I am continually impressed by the wealth of valuable information presented in such down-to-earth form, so I just want to express my appreciation.

As a radio instructor I urge my students to recognize that they can't make a place for themselves in electronics just on the strength of class and laboratory training alone—that it takes individual initiative too, and I'm pleased to recommend RADIO-ELECTRONICS to help them keep on their toes in this fast-moving field.

I feel that much credit is due those who direct this publication.

HUGH LINEBACK

Oklahoma Agricultural and Mechanical College
Stillwater, Oklahoma

CORRECTION

Dear Editor:

I presume that Mr. Jesse Dines, as well as readers of his very enlightening article, “Ceramic Capacitors,” June 1954, have discovered an erroneous formula used to calculate the frequency change of a tuned circuit due to a change in capacitance. The correct formula, of course, is

$$f_2 = \frac{f_1 \times \sqrt{C_1}}{\sqrt{C_2}}$$

which is derived directly from the well known formula

$$f = \frac{1}{2\pi \sqrt{LC}}$$

Therefore, the calculated frequency f_2 should read 40.17 mc instead of 40.33 mc. In other words, the frequency drift is somewhat less serious than shown.

Perhaps Mr. Dines might also have mentioned that a capacitor with negative temperature coefficient is desirable in critical circuits where other components, such as coils, have positive coefficients.

HERBERT H. LENK

Cincinnati, Ohio

"COLOR TV

TRAINING SERIES"
now appearing in

PF INDEX

the Monthly REPORTER for
the Electronic Service Industry



brings you a complete education in COLOR TV based on practical experience with actual receivers, and first-hand data developed exclusively by the editorial staff of PF INDEX . . . appearing month after month. You won't want to miss a single issue . . . so get

PF INDEX

AT YOUR PARTS DISTRIBUTOR

get it each month

only 25¢

always in stock

at **ALLIED**

PRECISION

TEST INSTRUMENTS

Standard of Accuracy, Quality and Value
For Over Twenty Years

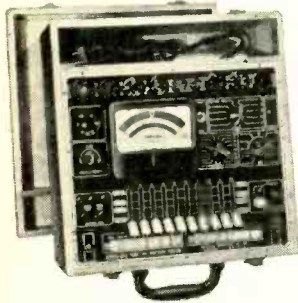

Model 612P Tube Tester

Standard RETMA emission type circuit. Tests all tubes; button 7- and 9-pin types, (sub-miniatures also), dual-capped high freq. types, FM and TV tubes, etc. Permits individual testing of multi-section tubes including tuning indicators, osc-conv., etc. Panel switch selects filament voltages from 0.75 to 117. Free-point lever element selection handles all multiple basing terminations. Has 4 1/2" meter accurate within 2%. Checks for shorts between elements. Noise and condenser test pin jacks. Dynamic "under load" test for A, B and C radio batteries. Sturdy hardwood case with cover and carrying handle; tool compartment. Easy-to-read, high-speed roll chart has provision for adding test setting data. 12 x 13 x 6". For 110-120 volts, 50-60 cycle AC. Shpg. wt., 19 lbs.

84 FX 433. *Net.*.....\$77.91

Model 612-MCP. As above, but in open-style portable metal case.

84 FX 444. *Net.*.....\$75.21



Model EV-10A-MCP VTVM Megohmmeter

Wide-range, true zero-center. Reads: 0-2000-200,000 ohms. 0-2-20-200-2000 megohms. VTVM ranges: 0-3-12-60-120-300-600-1200-6000 DC volts. RF volts (with RF-10A probe): 0-3-12-60-120 v. peak. AC, DC and output v.: 0-3-12-60-120-300-600-1200-6000, at 1000 ohms/v. DC current: 0-300 microamps. 0-1.2-6-30-120-600-1200 ma and 0-12 amps. 7" meter. Eight db ranges, -20 to +77. Steel case, 12 x 10 1/2 x 6". With coaxial leads. For 105-125 v., 50-60 cycles. Shpg. wt., 17 lbs.

84 FX 400. *Net.*.....\$97.75

RF-10A RF Probe. For above. Shpg. wt., 1 lb.

84 FX 419. *Net.*.....\$14.11



Model E-200-C Signal-Marker Generator

For efficient servicing of all AM, FM, and TV receivers; excellent for TV alignment. Covers 88 kc to 240 mc on eight bands (88 kc to 60 mc on fundamentals). Accuracy within 1%. Highly stable electron-coupled oscillator circuit. Outputs: Unmodulated RF, 400-cycle modulated RF, externally modulated RF, and 400-cycle sine wave audio output. Has 0-100% modulation control. Full vision, no-glare 6 1/2" direct reading dial with 0-100 vernier scale. Supplies 0-50 volts AVC-AGC voltage for alignment by constant bias procedure. Each range hand-calibrated. Complete with coaxial cable, dual LOW-HIGH cable connectors, and valuable 92-page book, "Servicing by Signal Substitution." In black ripple portable steel case. Size: 12 x 10 1/2 x 6". 105-120 volts, 50-60 cycles. Wt., 17 lbs.

84 FX 409. *Net.*.....\$76.93

Model E-400 Sweep Generator

For television and FM servicing. Frequency range is 2-480 mc; harmonically calibrated 240-480 mc. Narrow and wide-band sweep—freq. widths: 0-1 mc and 0-15 mc. Permits easy band width setting for both FM and TV; has built-in zero base-line reference. High and low output terminals. Stable variable frequency oscillator beats with either one of 2 fixed frequency oscillators. Has built-in multiple crystal marker-calibrator. Supplied with 2 crystals (2 mc and 4.5 mc). Special socket accommodates 4 crystals. Full vision, 6 1/2-inch dial. Dual RF attenuators provide continuously variable output level control of test signals. Separate output terminal provides synchronized narrow and wide-band sweep. Phasing control. Includes coaxial output cable and other inter-connecting cables. Copper-plated portable case. 10 1/2 x 12 x 6". For 105-125 volts, 50-60 cycles AC. Wt., 24 lbs. 84 FX 438. *Net.*.....\$136.95



All PRECISION instruments over \$45 available on Easy Terms—write for details

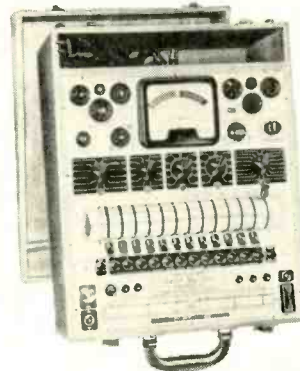

Model 10-12P Electronic Tube Tester

High-quality free-point tube performance tester featuring the reliable Precision Electronic circuit. Tests all tubes, including 4, 5, 6, and 7-pin octals, loctals, 9-pin novals, acornis, sub-miniatures and television types. Provides 17 filament voltages to 117 volts. Absolute free-point element selection by master lever selector (with single-action return) which locates every tube element regardless of position at tube base. Provides direct facilities for radio battery, ballast, noise, pilot bulb and condenser testing, neon continuity checks, and tests for shorts between tube elements. 4 1/2" meter has 2% accuracy. Double window high-speed roller tube chart; permits adding new tube setting data. For 110-120 volts, 50-60 cycles. In attractive hardwood portable case with removable cover and handle. 13 1/4 x 17 1/4 x 6 3/4". Shpg. wt., 23 lbs. 84 FX 426. *Net.*.....\$105.35

Model 10-12C. As above, but in black chrome-trimmed counter-type case.

84 FX 430. *Net.*.....\$110.00

PTA CR Adapter. Will test all picture tube types when used with any Precision Tube Tester. Tube need not be removed from set for testing. 84 FX 492. *Net.*.....\$6.61

CR-30 CATHODE RAY TUBE TESTER. Shows operating condition of TV picture tubes of all sizes and types, without removal from set. Measures actual beam current, not just total cathode emission. Checks all CR tube elements by absolute free-point 14-lever selection system. 4 1/2" meter shows tube condition and proportionate picture brightness. Built-in bridge-type VTVM. Speed roll-chart and test cable. Hardwood portable case. 6 1/2 x 13 1/4 x 17 1/4". 110-120 v., 60 cycles. Shpg. wt., 22 lbs. 84 FX 448. *Net.*.....\$102.65



Model ES-500A 5" Oscilloscope

An outstanding scope—built to the highest test instrument standards. Features push-pull horizontal and vertical amplifiers, internal phasable beam blanking, 1-volt peak-to-peak voltage calibrator, amplitude controlled positive-negative sync selection (locking circuit), and vertical pattern reversal switch. Uses 5CP1A CR tube. Vertical deflection sensitivity through amplifier, .02 rms volts/inch. Horizontal, .15 rms volts/inch. Response of both amplifiers, 10 cycles to 1 mc. Direct input impedance (horizontal and vertical plates), 3.3 megohms and 15-20 mmf. Input of amplifiers: vertical, 2 megohms; horizontal, 1/2 megohm. Has 3-step, frequency-compensated vertical input, attenuator, plus continuously variable vernier control. Sweep, 10 cps to 30 kc. Has Z-axis modulation input for blanking, timing, etc.; phasing control for line sweep operations. Audio monitoring phone jacks. Removable, rotatable light shield, 8 1/4 x 14 1/2 x 18". With 5CP1A, all tubes, shield, screen, and operating manual. For 110-120 volts, 50-60 cycles AC. Shpg. wt., 44 lbs.

84 FX 449. *Net.*.....\$170.23

SP-5 Probe Set. For above. Four probes for general-purpose and specialized TV signal tracing, alignment, wave form analysis, etc. Includes: high imp.-low cap. probe; crystal probe; isolating probe; shielded direct probe. With coax cable and quick-change connector to accommodate probes and plug to scope. Clip-on tips free hands for work. In Vinyl roll case. Shpg. wt., 3 lbs. 84 FX 491. *Net.*.....\$23.03

ALLIED STOCKS ALL PRECISION TEST INSTRUMENTS

We can supply all Precision products promptly. Including the following:

- 84 FX 422. Model 10-54-P Tube, Battery and 35 Range AC-DC Tester. Electronic combination tube and battery tester, and 20,000 ohms/v. DC and 1000 ohms/v. AC circuit tester. In portable case. *Net.*.....\$136.71
- 84 FX 428. Series 85 Multi-range Tester. A quality VOM. *Net.*.....\$39.15
- 84 FX 441. LC-1 Carrying Case for above. *Net.*.....\$9.31
- 84 FX 405. Model 858-P 54-Range Tester. Push-button operation. *Net.*.....\$60.27
- 84 FX 446. Model TV-2 High-Voltage Probe for above testers. *Net.*.....\$14.45
- 84 FX 417. Model EV-10A-P VTVM in wood case. *Net.*.....\$100.45
- 84 FX 443. Model EV-20 VTVM, all purpose portable AC-DC. *Net.*.....\$68.35
- 84 FX 445. Model TV-4 Hi-V Probe for above VTVM's. *Net.*.....\$14.45
- 84 FX 419. Model RF-10A RF Probe for above. *Net.*.....\$14.11

FREE Supplement No. 139

Send for our latest 56-page Supplement featuring new releases and special values. Make your selections at ALLIED from the world's largest stocks of tubes, parts, test instruments, audio equipment, amateur gear, industrial components—everything in electronics at lowest prices.

ALLIED RADIO

ALLIED RADIO CORP., Dept. 2-H-4
100 N. Western Ave., Chicago 80, Ill.

Send FREE Supplement No. 139

Please ship the following PRECISION instruments.....

Name.....

Address.....

City..... Zone..... State.....



**"ONE ASTATIC
MODEL L-12-U IS
LIKE A CASEFUL OF
OTHER CARTRIDGES"**



Astatic Universal Model L-12-U Crystal Cartridge—output is low (1.2 volts) with removable condenser harness ON; it's high (4.0 volts) with harness OFF.

THE ASTATIC MODEL L-12-U CRYSTAL CARTRIDGE

Astatic's dual-output, universal type crystal cartridge—the Model L-12-U—is a truly superior replacement in the great majority of 78 RPM installations encountered by servicemen today. No other cartridge is capable of broader application . . . yet, the Astatic L-12-U is guaranteed to provide performance equal to, or exceeding, the quality of the originals. It isn't a cure-all. But it is the closest thing to it that has so far been devised by electronic engineers. It is your best answer for simplification of inventory, for avoiding lost time and many problems of servicing. You'll be glad you got acquainted with the "handiest of all crystal cartridges," Astatic's L-12-U.

EXPORT REPRESENTATIVE
401 Broadway, New York, N. Y.
Cable: Astatic, New York.



CORRESPONDENCE

DECOMPLEXITY

Dear Editor:

Thank you for your timely editorial "Decomplexity" in the June issue of RADIO-ELECTRONICS. Having been either radio engineer or service technician—or both—for the past 40 years, may I offer my two cents worth? You are so right!

And I do not refer to the horrendous combinations of radio-TV-record player combined in a box as big as a grand piano, but to the average television receiver chassis. Those big combinations are "for the birds," those birds with more dollars to spend than sense.

In the first place, no television receiver should be so large as to be not portable—not movable by the owner or service technician. Most housewives want things moved occasionally, and the TV is no exception. And they could put handles on TV sets, too, especially the 21-inch variety. *Did you ever try to pick up a 36-inch cube weighing 75 or 100 pounds?* The first one isn't so bad—but the third or fourth one gets to be awkward. And the average TV has to be serviced two or three times a year, and *has* to go to the service shop.

As you say, the TV set of today—not to mention tomorrow's color TV—has grown to be a monstrosity. Radio engineers(?) have spent years of study and experiment to "complexify" it, adding trick circuits—a.g.c., no-flutter, no flopover gadgets—more as talking and selling points than for their practical value. But the unfortunate customer doesn't understand, so he buys, thinking he is getting a "scooper-doooper" masterpiece.

Verily, *how complicated can they get?* When are we going to call a halt and go back to the simpler things? If we don't, a stalemate will soon result, where no one can service and keep in operation all the complex monstrosities of engineering genius. And set owners will not be able to afford either the receiver or the high cost of specialized service work required. This is not necessary.

There are scores of different makes of television receivers, all different in their ways of arriving at the same objective. I have here between 25 and 30 different brands of TV receivers in all their various models. *All different!*

Talk about being a specialist! It reminds me of the wag who said that a specialist is a guy who learns more and more about less and less. If there were only one make of TV receiver we *might* become specialists, but we have to learn to solve all the riddles that the radio engineers have been able to concoct in their many years of endeavor to make things more complex.

Then—to top it off—they stick in cheap capacitors and other components where they think they won't cause trouble—in addition to mass-produced punchings for parts to reduce costs—and arrange them in such a layout that many of them are inaccessible.

(Continued on page 20)



SYLVANIA
*Aluminized
 Picture Tubes*
**ARE PACKED
 WITH PROFITS!**

Make old sets like new... have more satisfied customers!

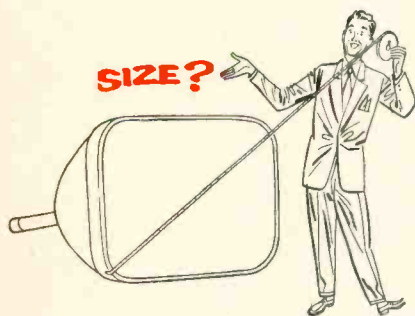

Interested in new sales records? You'll be heading in that direction when you replace old picture tubes with new Sylvania Aluminized Tubes.

Sylvania Aluminized Picture Tubes give terrific performance. They make old sets better and brighter than new by providing whiter whites—blacker blacks... a 6-times better picture contrast.

Sylvania Aluminized Picture Tubes are now available in most sizes for all popular TV sets. In other words, with Sylvania Aluminized Picture Tubes, you give your customers the best possible buy *and* the best possible service, including a full one-year warranty.

Remember, millions of set owners see and hear about Sylvania Picture Tubes on the nation-wide weekly television show "Beat The Clock." They know that they are famous for quality and dependability. For full details about aluminized tube replacement, write for Sylvania's "Aluminized Picture Tube Replacement Guide." Address: Dept. 4R-3808, Sylvania NOW!

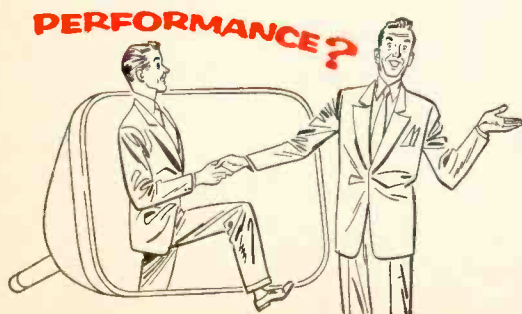
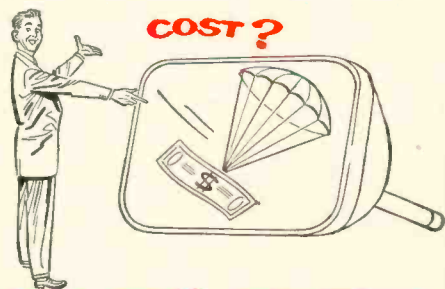

SYLVANIA

Sylvania Electric Products Inc.  1740 Broadway, New York 19, N. Y.

In Canada: Sylvania Electric (Canada) Ltd.
 University Tower Building, St. Catherine Street, Montreal, P. Q.

LIGHTING • RADIO • ELECTRONICS • TELEVISION

If you own Jackson Test Equipment

*You're all set
for Color*

Jackson "Service-Engineering" has always meant designing with the future in mind. And, compatible color proves the point. For, if you bought Jackson TV test equipment within the past few years, you'll find it's now as good for color as for black-and-white.

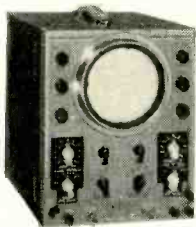

Jackson CRO-2 Wide Band Oscilloscope

Flat within 1 db to 4.5 mc. Ideal for displaying 3.58 mc color burst signals. New Low Capacity probe available has only 2 to 1 attenuation ratio, not more than 8 mmf effective input capacitance.

Jackson TVG-2 Television Signal Generator

Complete sweep and marker generator with separate crystal calibrator. Sweep width adjustable from 0 thru 18 mc. Sweep frequencies for IF or color video alignment. Built-in oscilloscope timing.

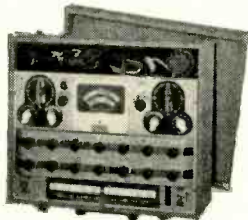
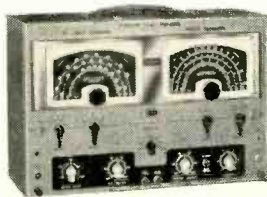

Jackson 707 Dynamic® CRT Analyzer

The CRT analyzer that completely and accurately tests *all* TV picture tubes, magnetic or electrostatic, black-and-white or color. Provides complete tests for shorts, beam current, grid condition and gas.

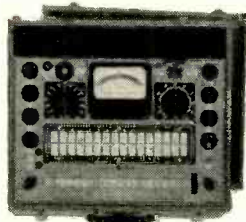

Jackson 648 Dynamic® Tube Tester

Features Sequence Switching for Super-speed set-up and tests. Saves valuable minutes in checking TV sets. Dynamic test method gives accurate, under-load test conditions. Life-line indicator, many other features.

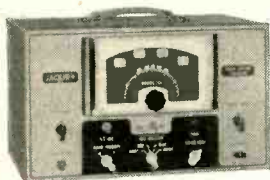

New! Jackson Color-Bar/White Dot Generator

If your shop is Jackson-equipped, here's the *only* new instrument you'll need for color. Provides single color bars, or multi-bar pattern, as well as white dots for convergence checks. For use with present 3-gun color tubes or any new development using NTSC standards.

*"Service Engineered"
Test Equipment*



16-18 South Patterson Blvd., Dayton 2, Ohio—In Canada: The Canadian Marconi Company

CORRESPONDENCE

The underside of many TV chassis consists of a space about two feet square and four inches deep, *completely filled* with hundreds of small parts, more hundreds of questionable soldered joints, and a maze of wires that discourages the repairman before he even attempts to trace a circuit.

On the other hand there are sets that amaze you at the comparative *lack* of parts and wires—and you wonder how the set can possibly perform so well with so few parts. These are the sets we service technicians fondly refer to as the "gutless wonders." They provide quite satisfactory service to most people in fair-signal areas, and—if they had a few more service adjustments—would go a long way toward the de-complexing of TV receivers.

These, the so-called gutless wonders, can even incorporate color facilities and still not have as many parts as a lot of the other makes have without them. And when those others incorporate color in addition to the mess already there, another chassis will be needed to contain the mess. The service technician may then throw up his hands in dismay—not to mention what else he may throw up.

The average TV set owner is now becoming aware that the table model is more desirable than the cumbersome console. First, because he may want to move it about occasionally, and second, because he knows that—at the present stage of (im)perfection at least—he will have to have it repaired at times. He also knows that *if he can take it to a repair shop*, it will be less expensive than to have a "specialist" call, take apart a complicated combination, and remove the chassis to his laboratory for a highly technical diagnosis, with the added expense of a return call and the reassembly of the set in the home.

Will this trend affect the manufacturer, or must the service technician boycott the makers of such complicated monstrosities and refuse to service their nightmares? It seems apparent that some manufacturers consider only the making and selling of their sets, with little regard to what happens after they have disposed of them. Let the suckers who buy them worry about that!

But it is the unhappy service technician who gets the rough time when he is expected to make the monstrosities work and perform in accordance with the claims put forth by the manufacturer and the dealers who peddle things they themselves know nothing about—and don't ever want to see again!

Even with the best of parts, careful connections and skillful workmanship, troubles can—and do—develop. Why increase the probability by the addition of many more—and such unnecessary—parts?

My hat is off to the gutless wonders—the less-complicated TV receivers. *Let's have more of them!*

OLE B. RITCHEY
Metz Radio and TV Clinic
Metz, Indiana

TRIO, LEADER IN ANTENNA DEVELOPMENT

NOW PRESENTS

most complete line in the industry!

No matter what antenna type is your favorite, TRIO now makes it—in better quality construction and at lower cost!

This is possible because TRIO has installed its own tube mill, added the most modern tool and die department, built a new production plant—and manufactures its own components. TRIO can thus control production and offer higher quality and better performance at *substantially lower prices.*

You are assured of fast delivery too, because TRIO now owns and operates its own trailer trucks, the most modern fleet in the industry.

See your jobber or write for the new TRIO catalog. It describes the most complete line available.

Illustrated below is only part of the TRIO line



Available in Blonde
or Mahogany



ONLY TRIO HAS THESE FEATURES:

- Now available pre-wired with either 65' or 90' of control cable for the most rapid installation. Merely connect spade lugs to control case terminals.
- Each rotator checked with its cable; eliminates defective cable and wiring faults.
- Not a single rotator returned since this feature added.
- Only rotator that receives a two hour bench test.
- Only rotator with two year guarantee.

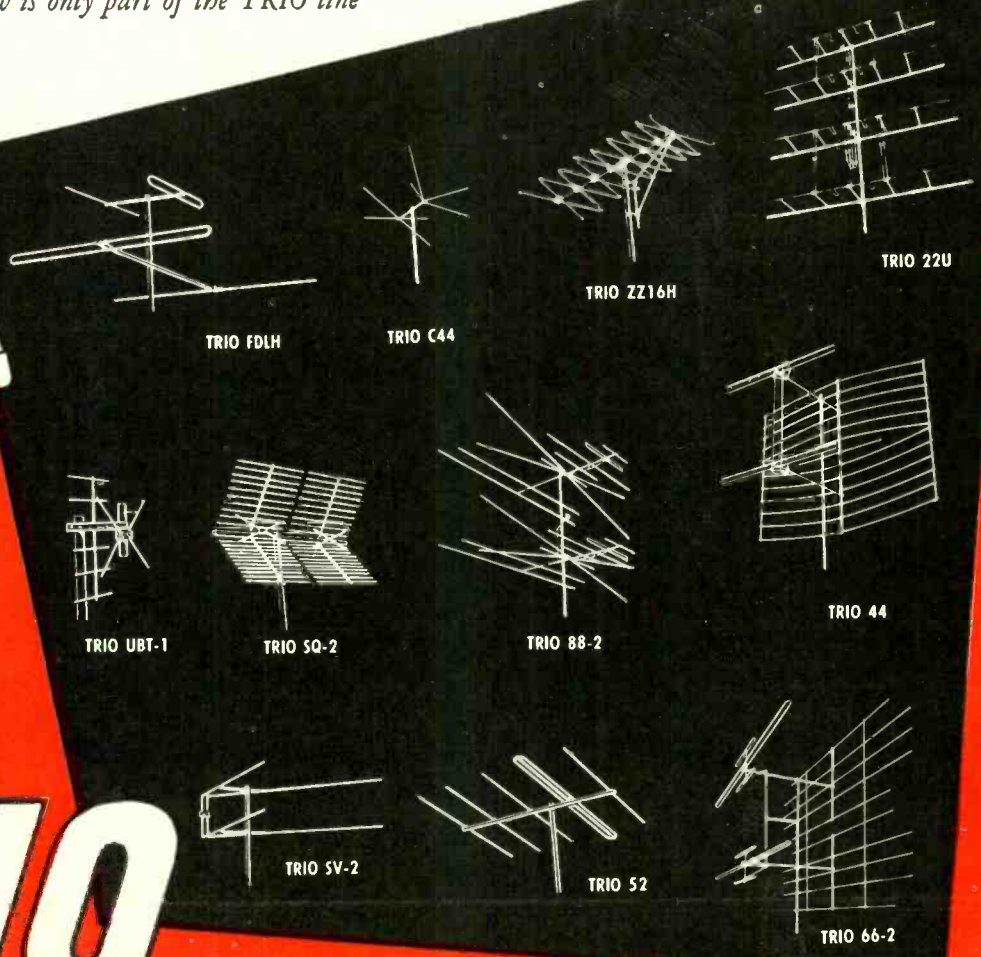

TRIO

EXPORT SALES DIVISION
SCHEEL INTERNATIONAL, INC.
4237 N. Lincoln Ave., Chicago, U.S.A.
Cable Address: HARSHEEL

TRIO MANUFACTURING CO. • GRIGGSVILLE, ILLINOIS

(advertisement)

GET THIS BOOK FREE! . . .



and you open the door to the
higher earnings and job security,
waiting for you in the

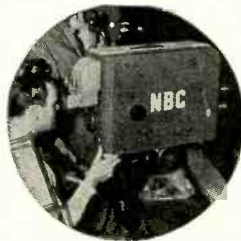

TREMENDOUS TV-RADIO ELECTRONICS INDUSTRY

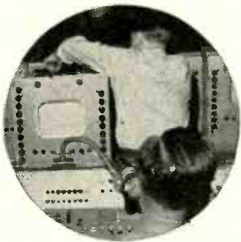

WHAT PRICE WILL YOU put on this book? \$1? \$5? \$100? \$1,000? Perhaps nothing? It has been worth thousands of dollars to some who have sent for it. It has upgraded thousands of careers in the booming, tv-radio-electronics industry. We would like to send it to you. It is free, and there is no obligation. It is called "YOUR FUTURE IN THE NEW WORLD OF ELECTRONICS."

In this factual, colorfully illustrated book you will see where you belong in the mushrooming electronics industry. You will see exactly how you can carve out a big job for yourself. You will see a practical, proven plan for getting a better job, better pay, security, satisfaction and success.

This information was compiled by authorities who have worked, and continue to work closely with some of America's most important electronics companies. We know what they want and need. We know what they expect from you, and we know how you can make yourself *what they expect you to be.*

The electronics industry is desperate for men—thousands upon thousands of men to fill the many vacancies brought about by phenomenal industry expansion.

Take television for example.

Already there are 381 tv stations on the air in 251 cities. Many more are under construction or on the drawing boards. Already there are 30,022,188 tv sets in use, in 60% of America's homes. Even when all homes get tv, there is the huge practically untapped market for "that second tv set," in each home. Color tv is coming into view! But tv is just a fraction of the picture. Electronics touches every phase of modern living—crime prevention, fire-fighting, public transportation—and thousands of well-trained men are needed to fill jobs in the manufacture, testing, servicing of equipment—as well as in broadcasting and telecasting.

Unquestionably, *this* is the field that promises you the kind of career and way of life you want. Our book, "YOUR FUTURE IN THE NEW WORLD OF ELECTRONICS," tells you at no cost to you, how you can really get ahead in this multi-billion dollar industry.

What is such a book worth to you? The thousands of dollars you may earn, over and above what you can now look forward to? The many dollars you might spend in time and money to find out from others how to get ahead? It's certainly worth the two minutes it takes to fill out and mail the coupon below. Put your own value upon it after you have read it. It is yours free, with no obligation. When you begin reading "YOUR FUTURE IN THE NEW WORLD OF ELECTRONICS," you will be taking the first big step in your march to good pay, job satisfaction, and career security—all yours in the rapidly expanding world of television, radio, and electronics. Act today.

CAPITOL RADIO ENGINEERING INSTITUTE

An Accredited Technical Institute Curricula. Founded in 1927.

3224 16th Street, N.W.

Dept. 148-A

Washington 10, D.C.

Send booklet "Your Future in the New World of Electronics" and course outline.

CHECK
FIELD OF
GREATEST
INTEREST

- Practical Radio Engineering
- Broadcast Radio Engineering (AM, FM, TV)
- Practical Television Engineering
- Aeronautical Radio Engineering
- TV, FM & Advanced AM Servicing

Name

Street

City..... Zone..... State.....

Check:

- Residence School
- Veteran

**DISCOVER EXTRA SALES . . .
EXTRA PROFITS . . .
EXTRA SATISFACTION . . .**

GET *Behind the*  *Ball*

. . . and, when you get behind this 8-Ball you're backing a real winner! Ward's famous 8-Ball auto aerials are styled for beauty . . . engineered to assure best radio reception . . . designed for easy installation from the outside. Ward offers eye-catching wire display racks, envelope enclosures and hand-out pieces . . . all planned to help you win extra sales and extra profits.

**GET THIS HANDY
HOLE SAW *FREE!***

The end label on every new Ward TCF-3B or TCF-3C 8-Ball carton is worth money to you. Save them and get this valuable, hole saw absolutely free. This saw will make it easier for you to install 8-Ball aerials . . . and faster, too.



Send us only 20 labels from Ward's 8-Ball cartons and we will send you this top quality hole saw, made to fit any 1/4" drill. It's a real time saver!

Ask your jobber for complete information



WARD

PRODUCTS CORP.
Canadian Distributor:
Atlas Radio Co., Ltd.
Toronto, Canada

Division of The Gabriel Co. • 1148 Euclid Ave., Cleveland 15, Ohio

SCIENTIFICALLY DESIGNED...

FOR BETTER TV RECEPTION

... BETTER PICTURE QUALITY



Scientifically designed to give top performance, Philco television antennas are products of extensive research into receiver requirements in all types of locations. Field tested electrical and mechanical designs provide

proper gain, directivity, bandwidth and impedance... long life and ease of installation. Now a wide choice of Philco television antennas give you better picture quality... build complete customer satisfaction... more sales for you!

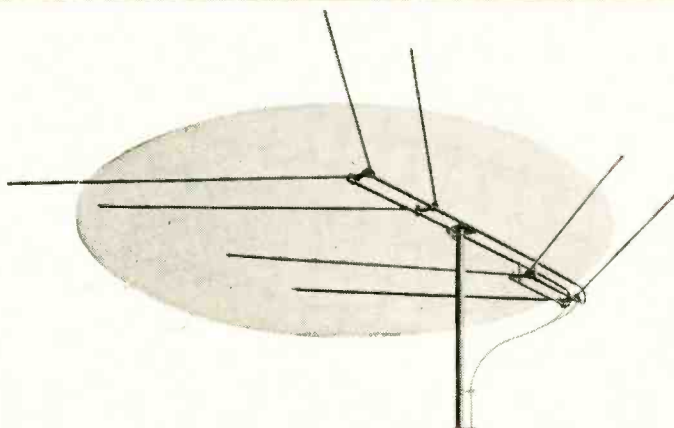

PHILCO ALL-CHANNEL UHF-VHF TROMBONE ANTENNA: The ideal antenna for areas having both UHF and VHF stations. The Philco Trombone can be stacked for VHF fringe area use. Completely pre-assembled at the factory... all-aluminum construction with dowelled elements: Part No. 45-1880.



PHILCO TWO-BAY SUPER CONICAL ALL-CHANNEL ANTENNA: Strong signal pickup on VHF channels 2 through 13, UHF channels 14 through 83... ideal reception in fringe areas... all-aluminum: Part No. 45-3096-2. Fringe area single bay design: Part No. 45-3096.

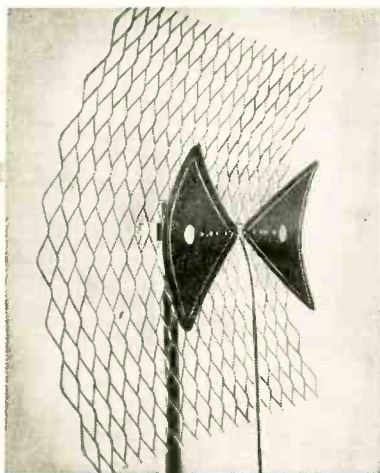
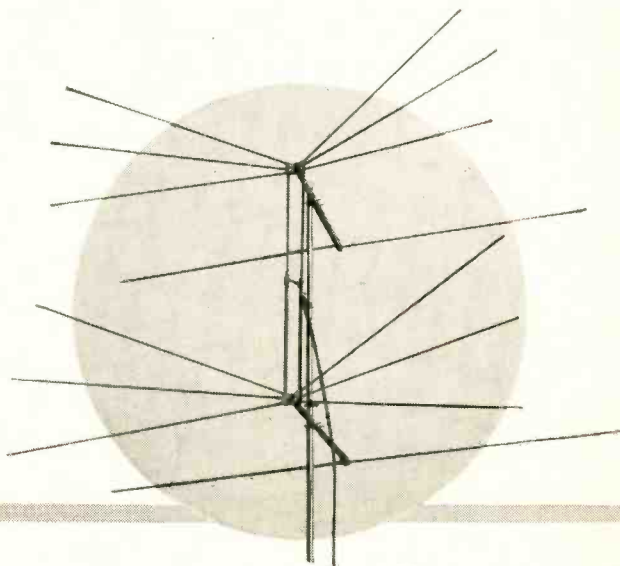

PHILCO PARAFLECTOR ALL-CHANNEL UHF ANTENNA: Pre-assembled, all-aluminum... 8 db to 10 db gain... outstanding fringe area performance... immediate mounting on existing masts: Part No. 45-3071. Bow Tie, Part No. 45-3069 and Bow Tie with reflector, Part No. 45-3070 provide top quality pictures in many UHF areas.

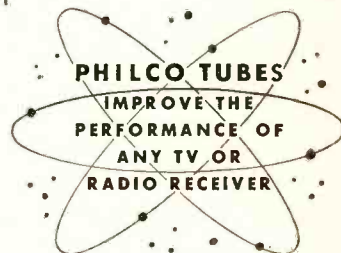

PHILCO CORPORATION

PHILCO

... SUPER PERFORMANCE

TV

ANTENNAS

PHILCO VHF "V" ANTENNA: Adequate reception on all VHF channels in most localities . . . heavy chrome plated three-section brass tubing . . . weighted plastic base holds antenna fully extended in any direction: Part No. AD-2643. Also available with aluminum tubing "V": Part No. AD-2643-1.

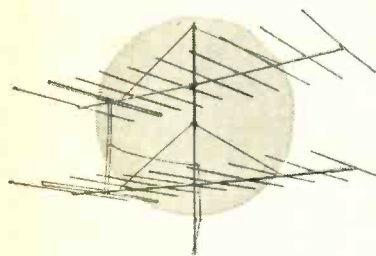

PHILCO TWO-BAY VHF LOW BAND YAGI ANTENNA: 10 elements . . . all-aluminum . . . factory pre-assembled. Top performance on channels 2 through 6 . . . 13 db to 15 db gain on various channels. Single bay Part No. 45-3112-2 through 6. Stacked version uses stack-harness Part No. 45-3267.

PHILCO HIGH BAND VHF YAGI ANTENNA: Pre-assembled, all-aluminum, 10 elements . . . high gain in fringe areas on channels 7, 8, 9, 10, 11, 12, or 13 . . . 10 db to 12 db gain on various channels . . . eliminates co-channel station interference: Part No. 45-3112-7 through 13.

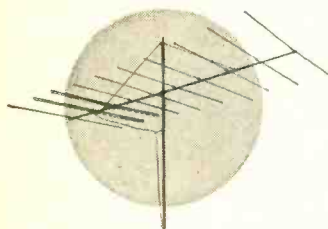
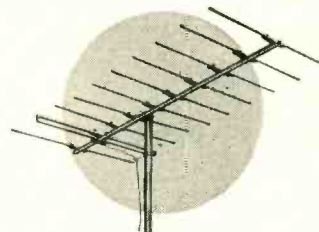

PHILCO BROAD BAND VHF YAGI ANTENNAS: All-aluminum, factory assembled for quick installation . . . high gain plus adequate band width. Three broad band models cover channels 2 to 6 . . . 4, 5, 6 . . . or 7 through 13: Basic Part No. 45-3112.

PHILCO GOLDEN YAGI UHF ANTENNA: Designed for 300 ohm operation . . . all steel construction . . . 11 db to 12 db gain on various channels . . . "Cronak" coated components resist salt air . . . humidity . . . six models cover entire UHF spectrum: Basic Part No. 45-1996.

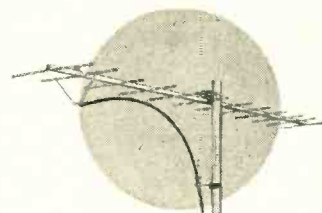

← PHILCO HEAVY DUTY ANTENNA ROTORS: →

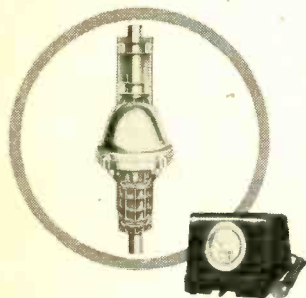

PHILCO MODEL P-4: Supports antenna installations weighing up to 150 pounds . . . completely weather sealed . . . factory lubricated for life . . . uses 4-wire rotor cable . . . modern direction meter control cabinet: Part No. 45-1974.

PHILCO MODEL P-11: Easily handles two-bay arrays . . . mounts on masts up to 1 3/8" in diameter . . . accurate direction control . . . heavy duty motor . . . streamlined design . . . uses 4-wire rotor cable . . . modern direction meter control cabinet: Part No. 45-1994.

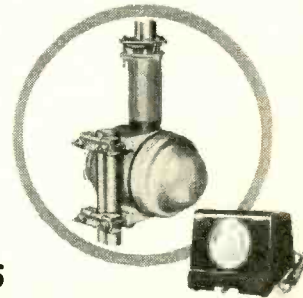

A complete line of powerful Philco TV antenna rotors as low as \$39.95

ACCESSORY DIVISION

'A' AND ALLEGHENY AVE. • PHILADELPHIA 34, PA.

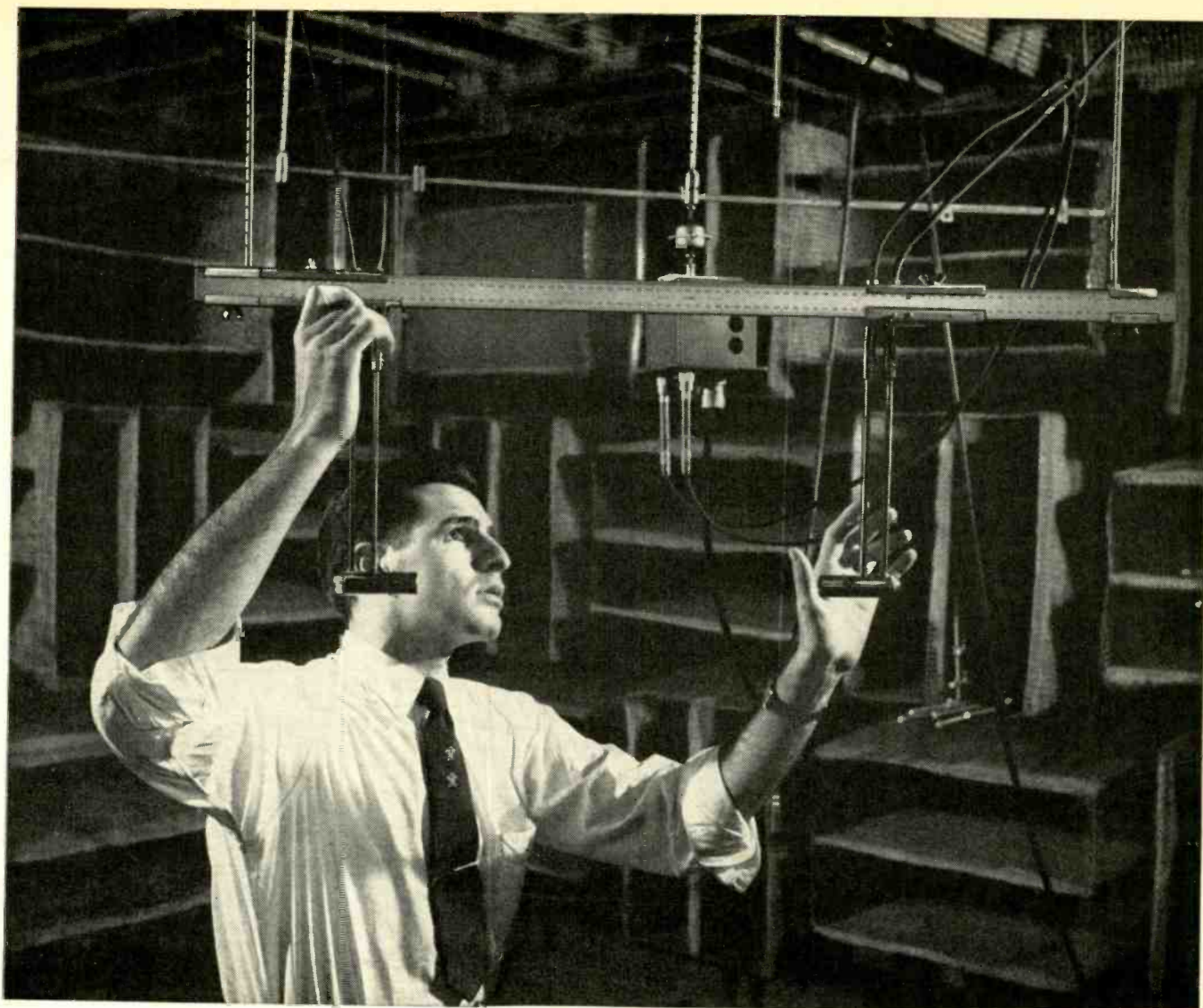

In a quiet room at Bell Laboratories an engineer scales off the distance between two condenser microphones during a calibrating test. Able to measure air pressure variations of a few billionths of an atmosphere, such microphones play a crucial role in the scientific study of telephone instruments.

SOUND STEPS ON THE SCALES

Those small cylinders facing each other are condenser microphones—measuring tools that play a vital part in making your telephone easier to hear and talk through.

They are being calibrated by an engineer at Bell Telephone Laboratories to give extremely accurate information on the kind of sound your telephone company handles. Armed with these vital fundamental data on what sound *is*, Bell Laboratories scientists

devise the instruments and equipment that transmit it best.

At Western Electric, manufacturing unit of the Bell System, a condenser microphone “listens” as your ear would listen to every telephone before it goes into service. The condenser microphone is but one of many precise tools that Laboratories scientists have developed to make telephone service better and more economical.

BELL TELEPHONE LABORATORIES

Improving America's telephone service offers careers for creative men in scientific and technical fields.





HERE'S YOUR BIG OPPORTUNITY!

TELEVISION

TECHNICIANS EARN BIG PAY!

L. C. Lane, B.S., M.A.
 President: Radio-Television Training Association
 Executive Director:
 Pierce School of
 Radio & Television



NO
 experience
 needed... I'll
 train you **AT**
HOME in your
SPARE TIME!
 Earn while
 you learn!



CIVILIANS! VETERANS!

PREPARE FOR A BRIGHTER FUTURE AS A TV TECHNICIAN
 Keep your present job while I prepare you **AT HOME**, using the same successful methods that have helped hundreds of men—many with no more than grammar school training—master television!

ENOUGH EQUIPMENT TO SET UP YOUR HOME LABORATORY

As part of your training, I give you **ALL** the above equipment you need and more to prepare for a **BETTER PAY TV** job. You build and keep a professional **GIANT SCREEN TV RECEIVER** complete with big picture tube, takes any size up to 21-inch... also a Super-Het Radio Receiver, RF Signal Generator, Combination Voltmeter-Ammeter-Ohmmeter, C-W Telephone Transmitter, Public Address System, AC-DC Power Supply. Everything supplied including all tubes!

EXPERT FM-TV TECHNICIAN TRAINING! My FM-TV Technician Course can save you months of training if you have previous Armed Forces or civilian radio experience! Train at home with kits of parts, plus equipment to build **BIG SCREEN TV RECEIVER**, and **FREE FCC Coaching Course!** **ALL FURNISHED AT NO EXTRA COST!**

FREE FCC COACHING COURSE! Important for **BETTER PAY JOBS** requiring FCC License. You get this training **AT HOME** and **AT NO EXTRA COST.** Top TV jobs go to FCC licensed technicians.

NEW! PRACTICAL TV CAMERAMAN & STUDIO COURSE! (For men with previous radio and TV training) I train you at home for an exciting high pay job as the man behind the TV camera. Work with TV stars in TV studios or "on location" at remote pick-ups! A special one-week course of practical work on TV studio equipment at Pierce School of Radio & TV, our associate resident school in New York City, is offered upon your graduation.

LEARN ALL ABOUT COLOR TV! I give you the latest principles and practical training in **TV COLOR!**

VETERANS!

MY SCHOOLS FULLY APPROVED TO TRAIN VETERANS under new G.I. bill! If discharged after June 27, 1950 — **CHECK COUPON!** Also approved for **RESIDENT TRAINING** in New York City at Pierce School of Radio and Television... qualifies you for full subsistence allowance up to \$160 per month. Write for details.

WARNING!

ALL VETERANS DISCHARGED BEFORE AUGUST 20, 1952, must be enrolled and **IN TRAINING** by August 20, 1954. Otherwise you lose your G. I. rights to a free education under **NEW G. I. BILL!** Don't put it off... time is short! **RUSH COUPON BELOW.** Tell your ex-G. I. friends!

YOU GET ALL 4 FREE!

GOOD SPARE TIME EARNINGS! Almost from the very start you can earn extra money while learning, repairing Radio-TV sets for friends and neighbors. Many of my students earn up to \$25 a week... pay their entire training from spare time earnings... start their own profitable service business. *Act now! Mail coupon and find out for yourself what a TV career can do for you!*

OPTIONAL: TWO WEEKS TRAINING IN NEW YORK CITY AT NO EXTRA COST! You get two weeks, 50 hours, of intensive Laboratory work on modern electronic equipment at our associated school in New York City—Pierce School of Radio and Television. And I give you all this **AT NO EXTRA COST** whatsoever, after you finish your home study training in the Radio-FM-TV Technician Course and FM-TV Technician Course.

RADIO-TELEVISION TRAINING ASSOCIATION

52 EAST 19th STREET, NEW YORK 3, N. Y.

Licensed by the State of New York • Approved by the VA



MAIL THIS COUPON NOW! No Salesman Will Call!

Mr. Leonard C. Lane, President
 RADIO-TELEVISION TRAINING ASSOCIATION
 52 East 19th Street, New York 3, N. Y. Dept. R-8B

Dear Mr. Lane: Mail me your **NEW FREE BOOK**, **FREE SAMPLE LESSON**, and **FREE** aids that will show me how I can make **BIG MONEY IN TELEVISION.** I understand I am under no obligation and no salesman will call.

(PLEASE PRINT PLAINLY)

NAME _____ AGE _____

ADDRESS _____

CITY _____ ZONE _____ STATE _____

I AM INTERESTED IN:

- Radio-FM-TV Technician Course
- FM-TV Technician Course
- TV Cameraman & Studio Course

VETERANS!
 Check here for
 Training under
 NEW G.I. Bill

EICO GIVES YOU ALL THREE!

1. LOWEST PRICE

Laboratory Precision at Lowest Cost in the Industry!

2. QUALITY

EICO guarantees FINEST QUALITY COMPONENTS, checked by stringent quality control tests.

3. PERFORMANCE

EICO guarantees you can build any EICO KIT—and save 50%.

425K 5" PUSH-PULL OSCILLOSCOPE KIT \$44.95 WIRED \$79.95

Feature-packed, performance proven, economy-priced — an EICO exclusive! Tens of thousands in use!

- Push-pull Vert. & Hor. amplifiers.
- High V & H sens.: 0.05-0.1 rms v/in.
- V & H response: 5 cps—500 kc.
- Useful to 2.5 mc.
- Sweep: 15 cps—75 kc.
- Z-axis intensity modulation.
- Direct connections to CRT plates.
- Tubes: 2-6J5, 3-6SN7, 2-5Y3, 5" CRT.

470K 7" PUSH-PULL OSCILLOSCOPE KIT \$79.95 WIRED \$129.50

America's greatest big-scope value—sets a new high for sensitivity at wide bandwidth!

- Vert.: flat ± 2 db 10 cps—1 mc, .01 rms v/in.
- Hor.: flat 10 cps—200 kc, —4 db at 500 kc, 3 rms v/in.
- Sweep: 15 cps—100 kc.

NEW! 232K PEAK-TO-PEAK VTVM with AC/DC UNI-PROBE KIT \$29.95. WIRED \$49.95.



- Measures directly p-p voltage of complex & sine waves: 0-4, 14, 42, 140, 420, 1400, 4200.
- DC/RMS sine volts: 0-1.5, 5, 15, 50, 150, 500, 1500 (up to 30,000 v. with HVP probe, & 250 mc with PRF probe).
- Res.: 0.2 ohms to 1000 megohms in 7 ranges.
- DC Input R: 11 megohms. 1% precision ceramic multipliers. $4\frac{1}{2}$ " meter. UNI-PROBE: Only 1 probe performs all functions—a half-turn of probe-tip selects DC or AC-OHMS! (Pat. Pend.)

221K VACUUM TUBE VOLTMETER KIT \$25.95. WIRED \$39.95.



- AC/DC volts: 0-5, 10, 100, 500, 1000 (up to 30,000 v. with HVP probe, to 250 mc with PRF probe, & peak-to-peak with PTP probe).
- Res.: 0.2 ohms to 1000 megohms in 5 ranges.
- DC Input R: 25 megohms.
- Large $4\frac{1}{2}$ " meter, can't-burn-out circuit.
- 1% precision ceramic multipliers.

1050K 6V & 12V BATTERY ELIMINATOR & CHARGER KIT \$29.95. WIRED \$38.95.

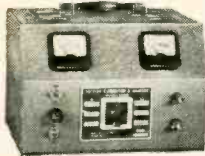

- 2 DC ranges: 0-8V (10A continuous, 20A intermittent); 0-16V (6A continuous, 12A intermittent).
- Continuous voltage adjustment: variac-type transformer.
- Separate voltmeter & ammeter.

OTHER EICO MODELS

- 249K Deluxe PEAK-TO-PEAK VTVM with $7\frac{1}{2}$ " METER & UNI-PROBE (Pat. Pend.) (similar to Model 232) KIT \$39.95. WIRED \$59.95.
- 214K Deluxe VTVM with $7\frac{1}{2}$ " METER (Similar to Model 221) KIT \$34.95. WIRED \$54.95.
- 488K ELECTRONIC SWITCH KIT \$23.95. WIRED \$17.95.
- 495K SCOPE VOLTAGE CALIBRATOR KIT \$12.95. WIRED \$19.95.
- 377K SINE & SQUARE WAVE AUDIO GEN. (20-200,000 cps) KIT \$31.95. WIRED \$49.95.
- 950BK R-C BRIDGE & R-C-L COMPARATOR KIT \$19.95. WIRED \$29.95.
- 1171K DECADE RESISTANCE BOX (0-99,999 ohms in 1 ohm steps, $\frac{1}{2}$ % accuracy) KIT \$19.95. WIRED \$24.95.
- 1180K DECADE CONDENSER BOX (100 mmf—0.111 mf in 100 mmf steps, 1% accuracy) KIT \$14.95. WIRED \$19.95.
- 1100K RTMA RESISTANCE SUBSTITUTION BOX (15 ohms to 10 megohms, $\pm 10\%$ accuracy) KIT \$5.50. WIRED \$9.95.
- 566K 1,000 Ohms/Volt MULTIMETER (Similar to Model 536, but with $4\frac{1}{2}$ " Meter and 7 Output Ranges) KIT \$14.90. WIRED \$18.95.
- 556K As above, but with 1% precision resistors. WIRED \$23.50.
- 944K FLYBACK TRANSFORMER & YOKE TESTER KIT \$16.90. WIRED \$23.95.
- 944K FLYBACK TRANSFORMER & YOKE TESTER KIT \$23.95. WIRED \$34.35.

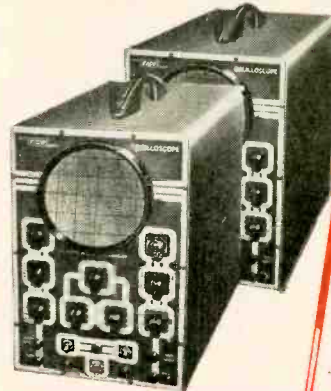

320 SIG. GEN. KIT \$19.95. WIRED \$29.95.

- Fundamentals 150 kc to 34 mc, calibrated harmonics to 102 mc.
- Pure or modulated RF, & Colpitts oscillator 400 cps sine outputs.
- Vernier knob tuning.



- ### 322K SIG. GEN. KIT \$23.95. WIRED \$34.95.
- As above, plus individual calibration of each of its 5 bands.

360K TV/FM SWEEP GEN. KIT \$34.95. WIRED \$49.95.

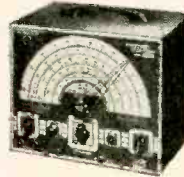

- Covers all VHF TV/FM channels & freqs. 500 kc—228 mc on fundamentals.
- Continuous sweep width control, 0-30 mc.
- Crystal marker oscillator.
- Variable phasing of 60 cps output.
- Precision 5 mc & 4.5 mc crystals, \$3.95 each.

145K MULTI-SIGNAL TRACER KIT \$19.95. WIRED \$28.95.



- Audibly signal traces all IF, RF, video & audio from ANT to SPKR or CRT without switching.
- Germanium crystal diode response well over 200 mc.
- 5" test speaker.

147K DELUXE MULTI-SIGNAL TRACER KIT \$24.95. WIRED \$39.95.



536K MULTIMETER KIT \$12.90. WIRED \$14.90

- 1000 ohms/v.; 31 ranges.
- DC/AC volts: Zero to 1, 5, 10, 50, 100, 500, 5000.
- DC/AC current: 0-1, 10 ma; 0.1, 1 A.
- Ohms: 0-500, 100 K, 1 meg.

526K MULTIMETER KIT \$13.90. WIRED \$16.90.

- As above, but with 1% precision resistors.



352K BAR GENERATOR KIT \$14.95. WIRED \$19.95.

- Easy rapid adjustment of TV V & H linearity without station-transmitted test pattern. VHF osc. adj. to any channel between 2 & 6.
- Adj. RF osc. & LF multivibrator generate V & H bars.

NEW EICO PROBES

SCOPE PROBES

- SCOPE DIRECT KIT \$2.75. WIRED \$3.95.
- SCOPE DEMODULATOR KIT \$3.75. WIRED \$5.75.
- SCOPE LOW CAPACITY KIT \$3.75. WIRED \$5.75.

VTVM PROBES

- VTVM PEAK-TO-PEAK KIT \$4.95. WIRED \$6.95.
- VTVM RF KIT \$3.75. WIRED \$4.95.
- HVP-1 \$6.95. HVP-2 \$4.95.

Extends range of VTVMs & voltmeters to 30 KV.

625K TUBE TESTER KIT \$34.95. WIRED \$49.95.



- Tests all conventional and TV tubes.
- Lever-action switches for individual testing of every element.

PIX TUBE ADAPTER for Tube Testers \$4.50

- Checks TV picture tubes while in set.

630K CATHODE RAY TUBE CHECKER KIT \$17.95. WIRED \$24.95.



- Checks all TV picture & C.R. tubes in set or carton.
- Detects shorted & open elements.
- Measures peak beam current (proportional to screen brightness)—reading directly in terms of tube condition.

565K MULTIMETER KIT \$24.95. WIRED \$29.95.



- 20,000 ohms/v.; 31 ranges.
- DC/AC Output volts: 0-2.5, 10, 50, 250, 1000, 5000.
- DC current: 0-100 ua; 10, 100, 500 ma; 10 A.
- Ohms: 0-2K, 200K, 20 meg.

555K MULTIMETER \$29.95. WIRED \$34.95.

- As above, but with 1% precision resistors.

315K DELUXE SIG. GEN. KIT \$39.95. WIRED \$59.95.

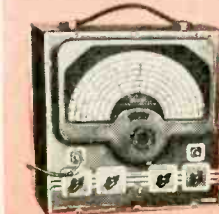

- 1% accuracy on all 7 ranges.
- Frequency: 75 kc to 150 mc.
- Output: over 100,000 uv.
- Vernier anti-backlash tuning.
- VR tube stabilized power supply, fully shielded chassis.
- 400 cps modulation; provision for ext. mod.

Separate Assembly & Operating Manuals supplied with each EICO KIT! SAVE OVER 50% — See the famous EICO line TODAY, at your local jobber. Write NOW for FREE latest Catalog C-8



Prices 5% higher on West Coast

© 54

ELECTRONIC INSTRUMENT CO. INC., 84 WITHERS ST., BROOKLYN 11, N. Y.

ROCKY ROAD TO SUCCESS

. . . Employment of specialized technicians is a complex undertaking . . .

THE two editorials "Wanted: Technicians" (February 1954 and "Specialization" April 1954) were responsible for a great deal more mail than any other two editorials this magazine has ever printed. From the vast volume of this correspondence, we have picked a few letters and are printing excerpts from them here merely to show the great variety in responses on the subject.

The letters themselves provide perhaps some of the best answers—better ones than we could have supplied ourselves. Evidently many readers did not see eye to eye with us on a number of points, which is not surprising because of the complexity of the subject itself. Then, too, readers of necessity have their own viewpoints and their own experiences. All this makes for great diversity in opinion.

One point, however, struck us forcefully when reading the many letters, and that is that few of the correspondents paid much attention to the *presentation* of their problems to would-be employers.

Unfortunately, today when large companies must sift personnel applications, employment managers are unconsciously influenced by many things. Automatically, the reviewer picks out the clearest, the best-written, and the neatest applications, often giving them preference. Employers are only human. When going through hundreds of letters, they have little patience to wade through poor, ill-written presentations. Many technicians, engineers, and others—and we know this from our own experience—spend little time with their applications.

One would think that when a \$5,000 or \$10,000 job was at stake, the applicant would secure the best talent to prepare the finest presentation that money could buy. This is rarely the case. Many applications are hand-written on a poor grade of paper, and even if they were typewritten, they are not too clear. Inevitably, such letters get little attention. *In these days of competition, it is necessary for the applicant to fight and battle all the way through.* Even if he calls in person, he still should have a well prepared application for record purposes.

Here is a true anecdote, very much to the point, which shows what we mean:

A clever mechanic in vain made the rounds of all factories in town. Undismayed, he had his wife type all his qualifications on heavy parchment sheets. These were bound into a thick cover book. He wrapped it carefully, then packed it in a 3 foot barrel and sent it to the biggest plant employer in town. The mechanic is now the assistant to the president.

Even after a job is landed, this is only a beginning. How well can you adapt yourself to your fellow workers? If you want to go ahead fast, the job is only a stepping-stone. *You must do much more than merely hold down a job; you must impress your employers day in and day out by acts, suggestions, and otherwise that you look for much more than just holding down a position.* Unfortunately, often the most excellent technicians don't do this. They do only what they are supposed to do—not one iota more. Then at the end of the year, they wonder why they do not go ahead. Being a good or even exceptional technician or engineer means nothing at all if this fact is not communicated to the management. No one can do this except the technician himself.

Now, let us turn to our correspondence. For lack of space the entire letter could not always be printed, but the substance in each case will be found intact.

Editor, RADIO-ELECTRONICS

(1) "Your article, 'Specialization,' in the April issue of RADIO-ELECTRONICS is well worth reading a second time. I believe it may influence my decision to this important question: 'Shall I return to the campus to pursue a Master of Science degree in Electrical Engineering?' Can you advise me in making this decision?"

"Upon receiving a Bachelor of Science degree in Electrical Engineering in 1952, I was commissioned in the United States Navy. Since then, I have graduated from the Navy Electronics Material School at Treasure Island, California, and served as Electronics Repair Officer on one of the escort carriers. I expect to continue to work with electronics until January 1955, my date of release from active duty.

"Since my senior year at the University of New Mexico, I have had a number of job offers from leading engineering concerns. The salaries have varied—all attractive. I have been advised to return to the campus by some of their spokesmen and to start to work immediately by others. Presently, I am undecided, but I feel that I should commence specialization by working for a Master's, regardless of the field I finally choose."

Roland L. Cooper
Alameda, California

Answer: *We certainly would recommend working for a Master's degree. In electronics, you can never have too good an education.*

Editor, RADIO-ELECTRONICS

(2) "Thanks for your words in the April issue of RADIO-ELECTRONICS. I am one of the mediocrities—but striving.

"I was riding high (I thought) as a supervisor of test operations of the production-line output of electronic devices at Hughes Aircraft, Culver City, California. Then, for family health reasons, we came to Tucson, Arizona. I was transferred to a job here at Hughes as Maintenance electrician. For nearly a year I fought the 'lowly' position. Suddenly I discovered that I didn't know much about all the devices which are my responsibility. Strange electronic control devices all about me and I was crying about the lack of opportunity to pursue my chosen profession.

"When I was discharged from the military service in 1945, I was handed a booklet which supposedly described my abilities as Chief Radio Technician, U.S.N.R. If today, after intervening years of study and experience, I really had all those qualifications, I believe I would be much closer to being an advanced specialist.

"Sir, it seems I am expending a good deal of energy. However, there is so much to know that many times I wonder if it is properly channeled (the energy). I have met no man in the field who can but rate your editorial as a challenge of the highest order."

D. B. Hatchett
Tucson, Arizona

Answer: *Your letter is self-explanatory. In our opinion, more study is needed, plus a little push on your part to move ahead to the position to which you are entitled.*

Editor, RADIO-ELECTRONICS

(3) "Being neither *summa cum laude* nor genius, my efforts shall perhaps go unread and, without doubt, unpublished.

"To begin with, perhaps it is an idiosyncrasy of the geni to ridicule those who are not similarly endowed, but, as Ben Franklin would have it, the stature of a man's character is judged by the company he keeps or competes with. By publishing the letter of an overzealous young man, you have accomplished nothing other than to point out the fact that youth is usually ignorant of: success is rarely attained through prescribed dosage of the so-called authorities, but is something that comes through years of experience and effort. As the most prolific inventor of our time has said, genius is more perspiration than inspiration.

Your conception of a specialist is somewhat incompatible with the term as it is generally understood, and is surely a misnomer of the person described. I seriously doubt that anyone can attain 'a thorough understanding of all phases of electronics.' It is possible to spend a lifetime studying and designing power supplies alone and leave many a stone unturned.

Wayne Dowd
West Covina, California

Answer: *Correct. Hardly a man alive can master all the intricacies of every phase in electronics. But many men, in specialization, can learn a great deal about certain specialized jobs in certain electronics industries, in our opinion.*

(Continued on page 122)

JUNCTION TRANSISTOR CHECKER

Varying transistor characteristics make this an especially useful instrument

By EDWIN BOHR

EVERY transistor owner needs some quick, convenient way of checking its performance characteristics occasionally. This simple, inexpensive instrument will do the job. For about \$6 worth of parts and a few hours of labor, anyone can build it.

Because individual transistors vary tremendously in their initial characteristics, a transistor checker is far more important to transistor circuitry than tube testers are to vacuum-tube circuits.

A type number is given to a transistor when it falls within certain maximum and minimum values called a production spread. This spread, for practical reasons, is large. Production techniques for maintaining rigid, uniform characteristics have not been developed. Often, the better transistors—with high current gain—are selected from a production run and given one type number while the lower gain units are given another. High-gain transistors are thus picked and marked for sale at a higher price.

Data sheets for lower-price transistors usually give only an *average* value of current gain without specifying any minimum. This is a "pig in a poke" situation where the buyer cannot be very sure about the quality of what he is getting.

Of two similar transistors purchased "off the shelf" one may operate well into the megacycle region; yet, the other may be good to only a few kilocycles. The purchaser of transistors must recognize these facts and realize that they exist even in brand new units that have never been connected to a circuit. The experimenter will find it highly advisable to measure the gain

of his transistors even before they are put into service. By doing this he can then reasonably judge the capabilities of the transistor and thus use it in circuits where it will perform most efficiently.

Adding to these initial unit-to-unit variations are the changes caused by the transistor's electrical and physical environment, such as excess humidity, careless overheating, and exceeded ratings. Wrong socket insertion, the surge of a charging capacitor, and excess supply voltage are just a few of the things that can cause harmful changes or permanent transistor damage.

It is a good idea to keep a record of a transistor especially when it is used in different circuits. An occasional gain check can reveal any transistor damage and isolate the cause.

Current gain

Current gain is the most useful single transistor measurement. This gain varies with the transistor's type of operation. For grounded-base operation, the current gain is termed *alpha* and is always less than 1 but approaches 1 for the junction transistor. Alpha is the ratio of collector current change to emitter current change for a fixed collector voltage. This is sometimes referred to as the short-circuit gain since it does not take impedance change into account. Manufacturers usually express the gain of their transistors in terms of alpha.

However there is another term that expresses current gain for grounded-emitter operation. This grounded-emitter gain is called *beta* and bears a simple mathematical relation to alpha.

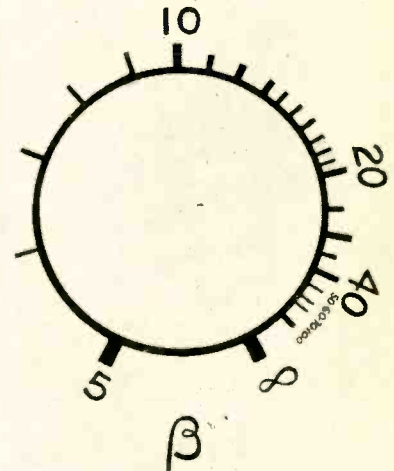

The calibrated balance-control dial.

If you know one you can easily find the other.

While alpha is always a decimal fraction less than 1, beta is expressed in small numbers greater than 1. With the beta measurement it is possible to glance at the gain and quickly know just how much better one transistor is than another. Alpha is not always so obvious. For example, how much better is a transistor with an alpha of 0.98 than a transistor with a 0.94 alpha?

The meaning and relationship between alpha and beta can be seen by observing the electron flow in the grounded-emitter and grounded-base circuits. These two circuits are shown in Fig. 1.

Suppose, as in Fig. 1-a, a signal change of 1 ma is applied to the emitter and this produces a 0.95 ma change in collector current. Alpha then must have a value of 0.95 because it is the change of collector current divided by the change of emitter current. Since the current flowing into a point must equal

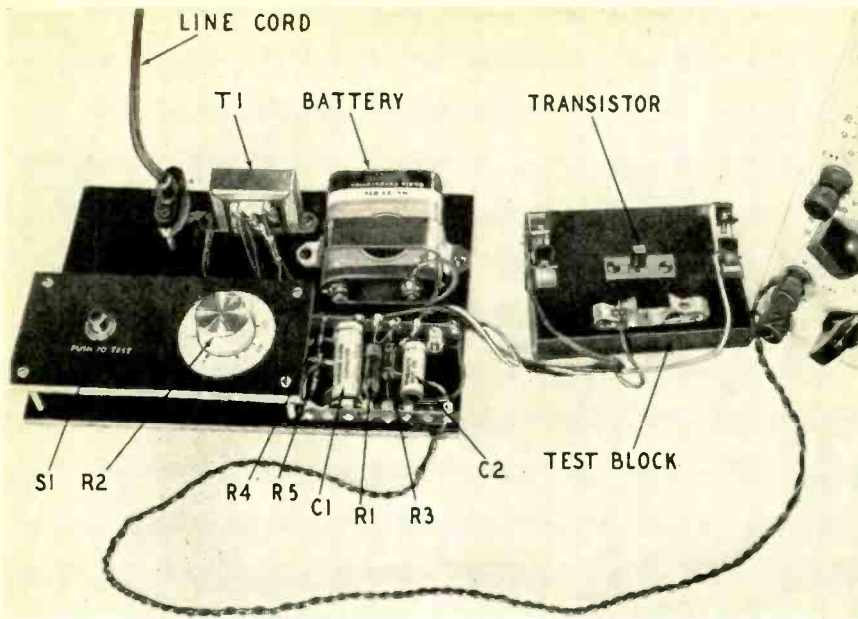

Checker uses separate transistor mounting board. Battery is 4.5-volt unit—3 flashlight cells may be used.

the current flowing out, the base current change is 0.05 ma.

If the same transistor is connected as a grounded emitter, a 0.05-ma signal applied to the base will create a 0.95-ma collector change. The gain in this case is the change in collector current divided by the change in base current. This is the beta gain, and it has a numerical value of 19 for this transistor (Fig. 1-b). It is this gain that the checker measures.

The arrows in Fig. 1 indicate electron flow to the connections of a p-n-p junction transistor. Delta (Δ) means "a small change of," and the numerical relation of alpha to beta is: $B = \frac{A}{1-A}$

Circuit

The junction transistor checker is a "null balance" instrument that measures the current gain by comparing the transistor input and output signals (Fig. 2). The circuit is simple and its accuracy is limited mainly by the care with which the balance dial is calibrated and the accuracy of R1.

A 60-cycle signal is applied to the transistor base through R1, R4, R5, and C1. The emitter is grounded to point A, the neutral point for the checker. Capacitor C1 prevents the d.c. bias on the base of the transistor from flowing into the measuring circuits. The

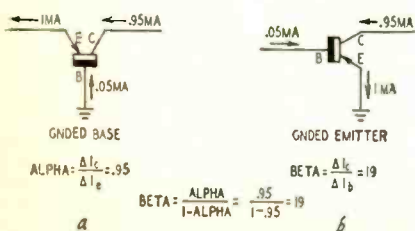

Fig. 1—Basic operation of the grounded base and grounded emitter circuits.

input signal is provided by a small stepdown transformer T1.

The signal to the base is called "constant current" because the high values of R4 and R5 almost completely determine the signal current flowing between the base and emitter terminals. The base-to-emitter resistance can vary from zero to several hundred ohms without appreciably affecting the transistor signal current.

Signal current flowing in the emitter-

Parts list for transistor checker

Resistors: 3—100,000 ohms, 1/2 watt; 1—5,000 ohms, 1% (precision); 1—1,000 ohms, potentiometer (linear). **Miscellaneous:** 1—.02- μ f, 1—.05- μ f, 600 volts, capacitors; 1—stepdown transformer, 25,000 ohms c-t to 3-4 ohms; (Stancor A-3857); 1—push-button switch, normally open, s.p.s.t.; 1—4.5 volt battery; 1—power cord; 1 transistor socket; 1—chassis; terminals, terminal strips.

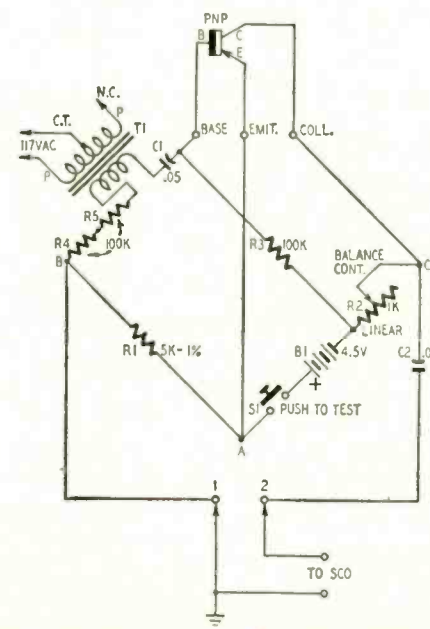

Fig. 2—The junction transistor checker—a "null balance" instrument.

base loop generates a small voltage across R1 directly proportional to the signal current. Thus the current is indicated by the voltage generated across R1.

Since quantities are compared in a balance circuit, the absolute value of the signal current is not too important—the voltage from T1 may vary without affecting the accuracy—but the accuracy of the comparison standard R1 is important. Resistor R1 must be a 1% precision unit.

A d.c. bias current, larger than the signal current, must be supplied to the base for class-A operation. The 4.5-volt collector battery supplies this current through R3.

The changing base input signal produces a larger collector-current output. This current flows through balance control R2, generating an output voltage proportional to the current. The voltage across R2 is opposite in phase to the voltage across R1. If they are equal in amplitude, they will cancel and no signal difference will exist between points B and C.

To measure transistor gain some null detector must be connected to the checker—an oscilloscope or audio amplifier will do—and R2 is adjusted until the 60-cycle output is zero or minimum. In this position the ratios of R1 and R2 are in the same proportion as the transistor input and output signals. The gain then can be read from the calibrated balance control.

Construction

Almost any reasonable layout is suitable for the checker. The original unit used breadboard type construction on sheet bakelite (see photo). However, this is not necessarily the best scheme of things. Bakelite is sometimes expensive and difficult to obtain.

The parts will fit under any 5 x 7 inch, or larger, chassis base. The terminals and balance-control dial could be

TEST INSTRUMENTS

mounted on top. This probably would be a good-looking and simple way to assemble the parts. To keep the cost of the transistor checker down, existing components were used as much as possible. This was not too difficult to do as most of the components consist of standard parts.

Several transistor test sockets mounted on bakelite were already available, so these were used "outboard" and connected to the checker by three short lengths of hookup wire. Otherwise, it might probably be more convenient to mount the socket on the checker.

Since the socket is used frequently, it is advisable to use the hearing-aid 5-pin socket. This type is considerably more rugged than some of the currently available sockets. The two unused pins can be pushed out and the holes plugged.

Step-down transformer T1 is an output transformer with half of the primary connected across the 117-volt a.c. line and with the voice-coil winding providing the test voltage. The transformer used matches 25,000 ohms plate-to-plate center-tapped, to a 3-4 ohm voice coil. Any brand of transformer with similar specifications should be satisfactory.

Filament transformers can be used for T1 by changing the total value of R4 and R5. The sum of R4 and R5 should be 100,000 ohms for each volt of the filament transformer. Thus, a 2.5-volt transformer would require 250,000 ohms.

Two components, R1 and R2, must be chosen with care. Either a deposited-carbon or metal-film resistor is satisfactory. These resistors are nominally rated at 1%, but the stock resistors I checked all fell within 1/2%.

Ordinary replacement carbon controls should not be used for R2. How-

ever, molded composition potentiometers such as the Ohmite type "AB" are O.K. These controls cost more than twice as much as radio replacement units; but their superior characteristics make the additional cost worth while. Several mail-order houses stock this type control.

Most wire-wound controls can be used. Even the dollar-or-less wire-wound controls are stable enough to be dial-calibrated for R2. The wire-wound laboratory potentiometers found on the surplus market are excellent for the checker.

Low checker impedances keep stray 60-cycle pickup problems to a minimum. The leads to the oscilloscope can be unshielded; and no shielding of any of the checker components is necessary. The ground terminal post from the oscilloscope is connected to terminal 1 and the input wire of the scope goes to terminal 2.

If the checker is built in a metal box or chassis, the chassis should be grounded to point A.

A television-type power connector is used to connect the 110-volt input. These TV connectors and cords make a very neat and inexpensive power-disconnect for experimental and commercial electronic equipment.

The collector battery can be any 4.5-volt battery. Three flashlight cells in series are also satisfactory.

Calibration

Beta markings on the balance dial correspond to specific resistance settings of R2. These values are given in the table. The maximum resistance of 1,000 ohms is equal to a beta reading of 5 since this resistance is 1/5 of R1. Minimum resistance of course indicates infinite gain.

One way to calibrate the dial is to connect an ohmmeter and rotate R2 to each of the resistance values in the table. At each of these points mark the beta value on a dial made from some firm material that can be conveniently marked on.

If the control is sufficiently linear, the dial shown in the photo may be used. Most experimenters will find this dial sufficiently accurate for their particular purpose.

Use of checker

Connect the oscilloscope, the transistor socket, and the 117-volt a.c. plug. Set the oscilloscope's vertical gain to maximum.

The horizontal deflection may be turned off. This gives straight-line vertical deflection, in which case the balance knob is rotated for minimum deflection when the transistor is checked.

Alternately, the horizontal deflection may be turned on and the scope may be synchronized with the line frequency. This procedure permits observation of

the signal waveform in the transistor circuits. If the scope does not have a 60-cycle position on the sync switch, set the sync selector to "external" and run a jumper from the 60-cycle "test" terminal to the external sync terminal. Synchronizing the scope with the line, rather than the internal signal, makes the horizontal sync very stable and independent of both the phase and amplitude of the vertical deflection.

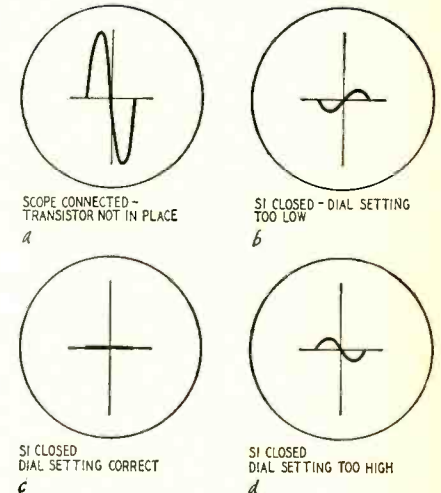

Fig. 3—Oscilloscope test patterns.

While S1 is open, the oscilloscope input floats and there is large 60-cycle pickup from strays (Fig. 3-a). With the transistor in place and S1 still open, the stray pickup will be clipped since the transistor functions as a simple rectifier.

When S1 is pushed, the scope display indicates how close to balance the checker is. The patterns either side of and at balance are shown in Figs. 3-b, 3-c, and 3-d.

Because the signal from the checker is in the order of millivolts, the deflections with S1 closed will be small but large enough for use with even the lowest gain scopes. Do not expect large deflections.

If an oscilloscope is not available, the output from the checker can be fed into the microphone or variable-reluctance phono input of an audio amplifier. Rotate R2 until a minimum hum level is heard. Do not use an amplifier that does not have a transformer power supply.

To check n-p-n transistors, simply reverse the connections to the 4.5-volt battery. This is the only necessary change.

A total of 13 new transistors have been tested on the checker. The average beta should be 9 according to the data sheet. One transistor had a gain of 14, while three units measured gains dangerously close to 5. The remainder of the transistors had betas of about 7 or 8. Of course it is not implied that this was a representative group of transistors; but it does point up the earlier statement about variations that must be expected.

END

BETA AND BALANCE CONTROL RELATIONSHIP

Beta Value	R2 Setting (ohms)
5	1,000
6	833
7	714
8	622
9	555
10	500
11	455
12	417
13	385
14	357
15	333
16	313
17	294
18	287
19	263
20	250
25	200
30	167
35	143
40	125
50	100
60	83.3
70	71.4
100	50.0
Infinity	00.0

TEST INSTRUMENTS

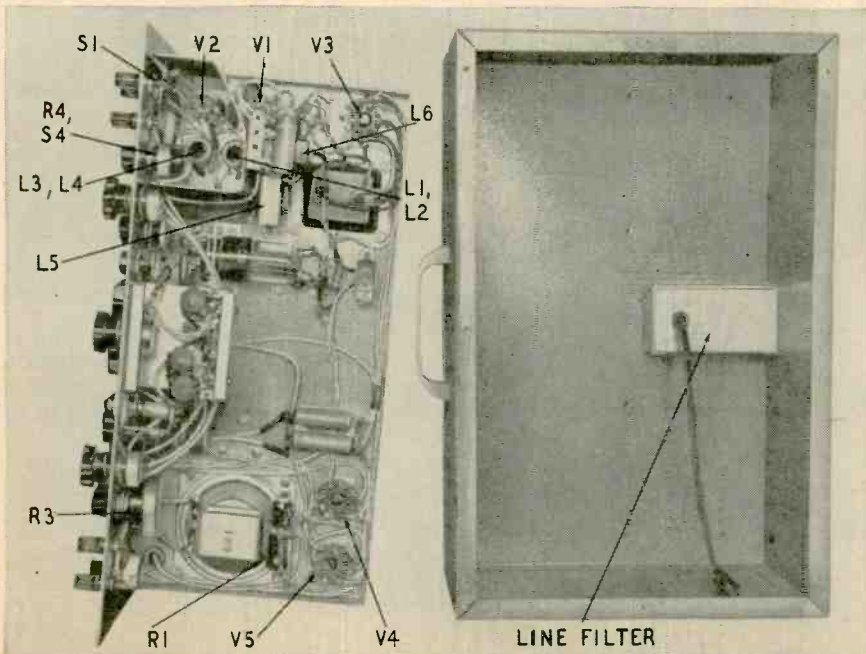
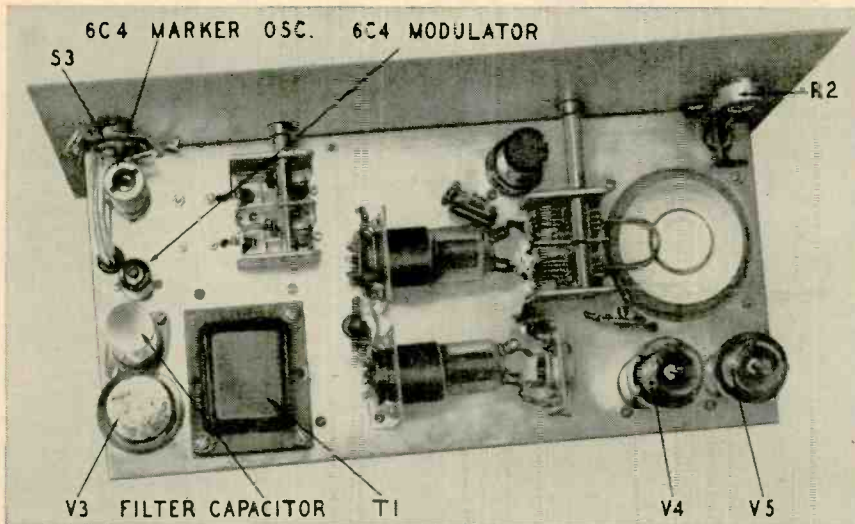
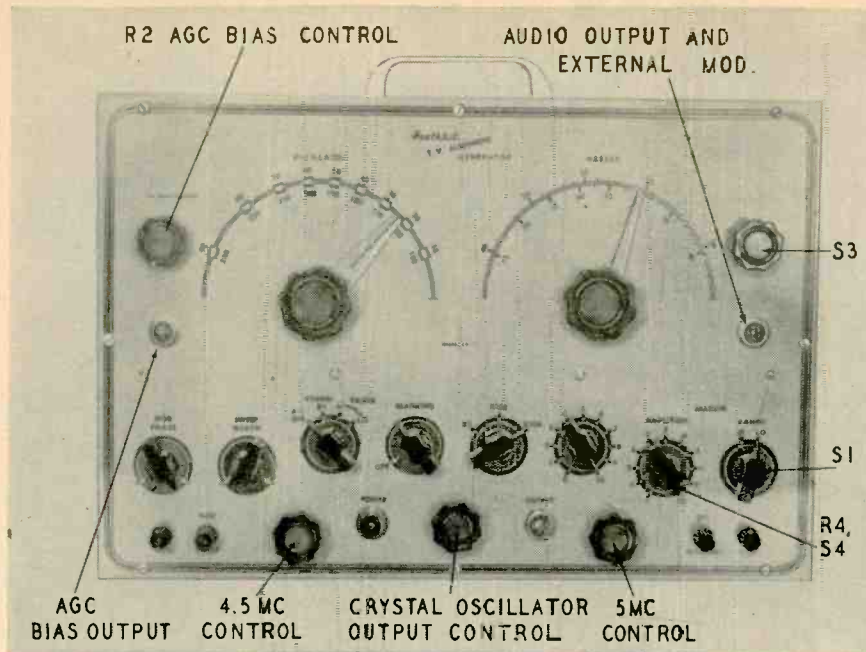

siderable effect on the response curve, and the manufacturer's recommended value should always be used. Having a range of 0 to 45 volts, this negative voltage may be used also as a cutoff bias for the control grid of a receiver's horizontal output tube to eliminate the pulse radiation from the high-voltage supply that sometimes causes a series of spikes to appear on the response curve and its base line.

The power line cord was shielded and a separately shielded line filter was added to reduce the r.f. leakage from the instrument.

Construction

The layout of the additional components is evident from the photographs. The bias output control and connector are mounted on the left side of the panel, and the audio modulation switch and connector are on the right. The marker oscillator is separately shielded. It is very important that all the new parts be mounted securely with lock washers to prevent loosening caused by vibration from the sweep motor. Bypass capacitors C5 and C6 should be grounded at a common point with the tuned circuits and should go directly to the tube socket of V2. The wiring between V2, band switch S1, and coils L1, L2, L3, and L4 should be as short as possible.

Using the generator

When aligning a TV receiver with a sweep generator and markers, it is a disadvantage to use a wide-band oscilloscope because the marker heterodyne frequencies will be visible for several megacycles on each side of zero-beat, distorting the alignment curve and making it very difficult to spot the zero-beat point. Since the alignment curve is basically a 60-cycle square wave, the oscilloscope response can be limited to a few thousand cycles without noticeably affecting the shape of the curve, yet keeping the marker more confined about its zero-beat position, thus making it distinct and much more easily recognized. The high-frequency response of the oscilloscope can be temporarily reduced by shunting a capacitor of approximately $.006 \mu\text{f}$ across the oscilloscope vertical input terminals.

With some combinations of sweep generators and oscilloscopes, the two sweep curves cannot be properly superimposed, especially when using a narrow sweep for sound i.f. alignment. This difficulty can be corrected by installing a d.p.d.t. switch, S2, to reverse either the leads going to the sweep motor or the ones feeding the phasing network for the horizontal deflection of the oscilloscope.

The 360-cycle oscillator can be used to modulate the variable marker oscil-

Top—The modified Heathkit generator. Center and bottom left—The top—and underchassis views of the generator. Bottom right—The r.f. line filter.

SCOPE FREQUENCY COMPENSATION

By ELLIOTT A. McCREADY

MOST lower-priced oscilloscopes, including many of the scope kits on the market today, have vertical amplifiers with adequate frequency response—only if the gain control is set to maximum position. This drawback limits the usefulness of the oscilloscope.

There are several methods of compensating for this limitation. A separate step-type attenuator can be used in conjunction with the scope, or a lower-resistance vertical gain control can be substituted. The second method reduces the vertical gain excessively and the first means another piece of equipment on the already too-small

workbench.

A self-contained vertical frequency-compensated gain control seems to be the answer to the problem, but such an answer is not as simple as it seems. A step type attenuator, if substituted for the regular gain control, would require at least 8 to 10 positions to give even minimum coverage of the numerous input voltages applied to the instrument. Even so, this would not provide continuously variable control of the input, and would require at least 8 to 10 resistors and 16 to 20 fixed and variable ceramic capacitors. The size and cost would be prohibitive.

There is, happily, a fairly simple

answer to this problem: the fact that most scopes use a triode as the vertical input amplifier. Mine uses a 6J5. If the octal socket of the 6J5 were rewired it would be possible to use half of a 6SN7 as the vertical input amplifier. The other half could then be used as a cathode follower with a three-step compensated attenuator at the input and a continuously variable gain control at the output of this stage.

The circuit I used is not unique and is a composite of various other such circuits which have appeared in various radio and other magazines.

The three-step attenuator in the input circuit maintains a high input impedance—approximately 40 μmf and 2 megohms. The frequency response of the unit, with any setting of the attenuator or gain control, is as good as the final stage of vertical amplification in the original circuit.

Locating the controls on the scope panel may present a problem. The 3,000-ohm gain control can be substituted for the original gain control. Locating the attenuator switch was, for me, a problem that required some thought and considerable maneuvering. It must be close to the vertical input circuit to reduce stray pickup.

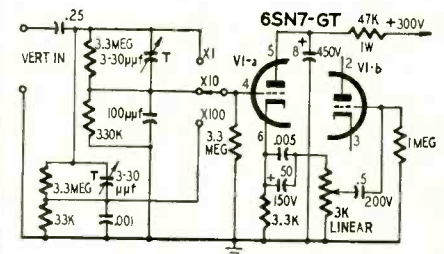

V1-b replaces original amplifier and is wired same as the original circuit.

Parts for frequency compensation

Resistors: 1—3,300, 1—33,000, 1—330,000 ohms, 1—1 megohm; 3—3.3 megohms, 1/2 watt; 1—47,000 ohms, 1 watt; 1—3,000 ohms, linear taper, carbon potentiometer (replaces original gain control); **Capacitors:** 1—100 μmf , 1—0.01 μf , 1—0.005 μf , ceramic; 1—.25 μf , 600 volts; 1—0.5 μf , 200 volts; 2—3.30 μf , trimmer; 1—8 μf , 450 volts, 1—50 μf , 150 volts, electrolytic. **Miscellaneous:** 1—6SN7-GT tube; 1—3-position, single-pole switch.

Calibrating the attenuator requires a square-wave generator. Set the generator to approximately 1,000 cycles and the attenuator to the "X 100" position. Adjust the appropriate trimmer for a flat-topped trace on the screen of the scope. Repeat this procedure with the attenuator switch in the "X 10" position.

This modification will certainly be worth while to the owner of any low-priced scope and can be built with a minimum of parts and reworking. END

lator or as an independent source of audio. When the modulation switch is set at INTERNAL, the 360-cycle sine wave is available at the panel connector

Parts for TV generator improvement

Resistors: 1—1,000, 1—10,000, 1—56,000, 1—100,000, 1—270,000, 1/2 watt; 1—5,600, 1—200,000, 1 watt; 1—2,000, adjustable (set at 1,700), 25 watts. **Potentiometers:** 1—500, linear (with switch), 1—200,000, linear; 1—150, linear, 2 watts. **Capacitors:** 1—51 μmf , NPO, 1—0.01 μf , 2—0.015 μf , 1—0.1 μf , ceramic; 2—.05 μf , 2—0.1 μf , 1—0.25 μf , 200 volts; 1—10 μf , 1—15 μf , 450 volts, electrolytic. **Miscellaneous:** 1—5V4-G, 1—0C3, 1—0D3, 2—6C4, tubes; 1—power transformer, 600 volts ct at 70 ma, 5 volts at 2 amp, 6.3 volts at 3 amp (Thordarson T 22R02); 1—filter choke, 8 h at 80 ma; 1—choke, 6 h at 40 ma (UTC R14); 2—radio-frequency chokes, 7 μh at 1 amp; (Ohmite Z-50); 3—d.p.d.t. switch (Centralab 1462); 1—s.p.s.t. switch; 1—s.p.s.t. switch (on marker-amplitude control).

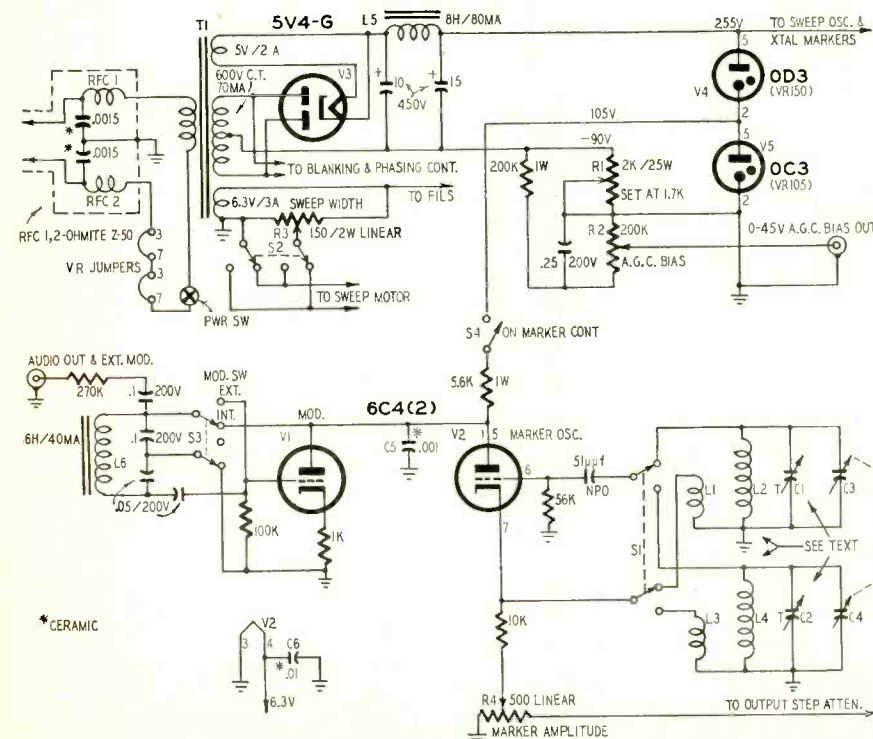
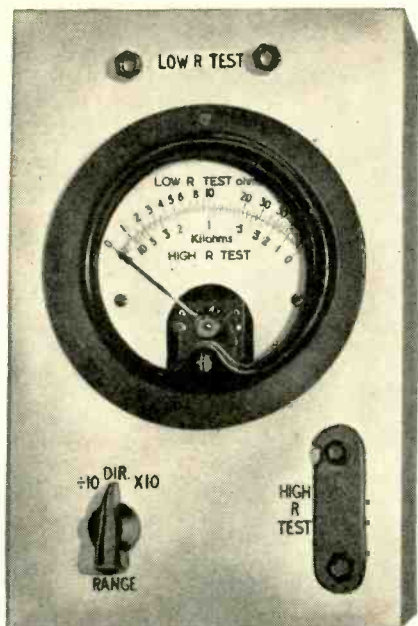

Fig. 3—Schematic diagram for improving the television alignment generator.

HIGH-ACCURACY

OHMMETER



Front of the ohmmeter. Zero control is screwdriver adjusted through hole in case

A practical test instrument capable of measuring extremely low resistance values—simple to construct

By **NORMAN H. CROWHURST**

THE simple direct-reading ohmmeter circuit, which is really an extension of the earlier and cruder continuity tester, is extremely useful for making resistance checks where high-order accuracy obtainable by using bridge methods is not required. It has an advantage over the bridge because it does not need manipulation of calibrated components to obtain a balance before the answer can be calculated; the required value appears as a direct reading on the ohmmeter scale.

It is surprising, however, to find that many ohmmeter circuits use arrangements where the accuracy is unnecessarily dependent upon a specific supply voltage, whether this comes from a battery or the power line. Whichever

resistance will give exactly half-scale reading. In this example, when the battery voltage is 1.6, the total resistance of the circuit to give full-scale deflection of 1 ma, with the terminals short-circuited for zero adjustment, will be 1,600 ohms. Having set the zero point, an external resistance equal to this will reduce the reading to half scale. So, for maximum battery voltage, the half-scale reading should be 1,600 ohms. When the battery drops to 1.2 volts, the total series resistance for full-scale current deflection, with terminals short-circuited, will drop to 1,200 ohms, so the half-scale reading should then be 1,200 ohms.

The question comes, what reading should be put on the scale at this point? Probably 1,500 ohms, because this is based on a battery voltage at the nominal value of 1.5. But the range of zero adjustment necessary to use the battery over its workable range of voltages means that the value indicated as 1,500 ohms may be anything between 1,200 and 1,600, according to the conditions of the battery.

Fig. 2 shows a circuit that reduces this possible error. We start by deciding that the center scale reading is going to be 1,000 ohms. This means that the total resistance in the circuit, with the terminals short-circuited, must also be as near as possible to 1,000 ohms.

At the maximum battery voltage, this will allow a current of 1.6 ma, while at the lowest battery voltage the current with the terminals short-circuited will be only 1.2 ma. So the meter shunt must be arranged to pass from 0.2 to 0.6 ma at full-scale deflection for zero adjustment range.

Assuming the meter has a full-scale voltage drop of 150 millivolts (resistance of 150 ohms), then the shunt resistor, to pass 0.6 ma, corresponding to maximum battery voltage, should be 250 ohms; while to pass 0.2 ma, it must be 750 ohms. Using the nearest practical values, a fixed 220-ohm resistor in series with a 500-ohm potentiometer provides the necessary range of coverage.

Now to work out the value of the series resistor: First we need to know the resistance of the meter with its shunt. The actual meter resistance, in this example, is 150 ohms. At maximum battery voltage, when the meter shunt is 250 ohms, the parallel combination of 150 with 250 ohms is about 94 ohms. For the lowest battery voltage condition, the parallel combination, of 150 ohms with 750 ohms, rises to 125 ohms. To ease the figuring, say the variation is from 95 to 125 ohms. Then the average value of the meter with its shunt is 110 ohms. This would be subtracted from the total circuit resistance of 1,000 ohms, which leaves 890 ohms for the series resistor.

In practice, then, the total circuit resistance varies from 985 ohms at maximum battery voltage zero setting to 1,015 ohms when set for minimum battery voltage. So the center-scale reading will always be within 1.5% of its calibrated value.

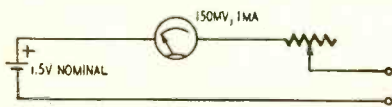

Fig. 1—A simple ohmmeter circuit.

source of voltage is used, it is desirable that the accuracy of the instrument be almost independent of supply-voltage variations within a workable range.

As an example suppose the ohmmeter, built around a milliammeter with full-scale deflection of 1 ma, is to use a dry-cell unit nominally rated at 1.5 volts. When brand-new these cells give a voltage of practically 1.6, and they can probably be used until the voltage falls to 1.2 before they become seriously unreliable. A circuit for such a meter is shown in Fig. 1. This is a simple series circuit where equal current flows through each component.

To consider the accuracy of any ohmmeter calibration, the easiest method is to consider what value of

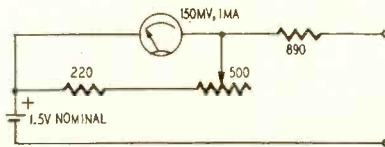

Fig. 2—Zero adjustment method that considerably reduces the dependence of accuracy on the battery voltage.

Accuracy can be increased still further by making the fixed series resistor a greater proportion of the total circuit resistance, using a higher nominal battery voltage so full-scale deflection is still possible. Suppose, for example, three 4.5 volt batteries are connected in series to give 13.5 volts nominal; these batteries will have extremely long life with a maximum current drain of only a little over 1 ma for full-scale deflection. A terminal voltage variation from, say 11 to 14 could be allowed. The supply voltage is approximately 10 times the previous figure, so the total series resistance in circuit, to determine the nominal center-scale reading, could be 10,000 instead of

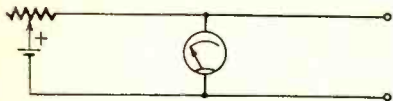

Fig. 3—A shunt ohmmeter circuit.

1,000 ohms. Subtracting the mean value for the instrument with its zero adjuster shunt of 110 ohms, this means the series resistor should be 9,890 ohms, and the variation of total circuit resistance is now only .15% from its average value of 10,000 ohms. Using the high battery voltage, the inaccuracy due to battery voltage variation is thus much less than the probable inaccuracy

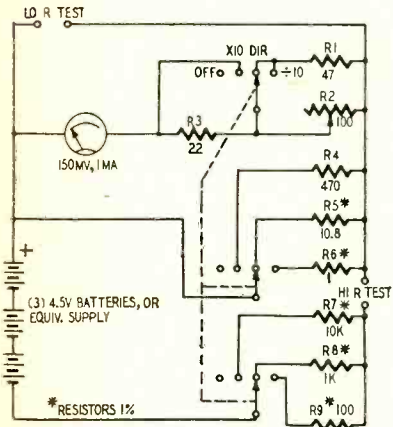

Fig. 4—A high-accuracy ohmmeter requiring a minimum of calibration.

in the original calibration of the milliammeter.

Both these circuits are for what is usually described as the "series" ohmmeter circuit, because the resistance to be measured is connected in series with the meter and its supply voltage. It is obvious from the values in the above discussion that it is suitable for measuring relatively high resistances, but could not easily be used to measure such resistances as loudspeaker voice coils, which would give a reading indistinguishable from a short-circuit.

For this purpose a better instrument is the shunt-reading ohmmeter, shown in Fig. 3. In this circuit the instrument is adjusted to full-scale deflection with the terminals open-circuit. When a resistance is connected to the terminals it provides a shunt for the meter, and

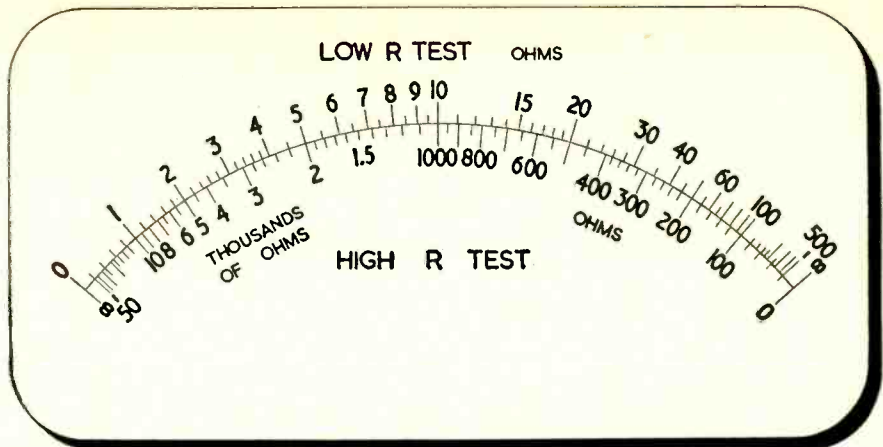

Fig. 5—Scales for Fig. 4. Low scale is for shunt operation; high is for series.

gives half-scale reading when the external resistance is approximately equal to the internal meter resistance.

Note the word "approximately." Some books omit it in describing this instrument. Assuming that the battery voltage comes from the original single cell of nominal voltage 1.5, and the instrument is still the 150-mv, 1 ma full-scale job, then at the nominal battery voltage, with no resistance connected, there will be 150 millivolts across the meter and a 1.35-volt drop across the series resistor. When the meter is shunted with a resistor to bring it down to half scale, there will be only a 75-millivolt drop across it, so the drop across the series resistor must rise to 1,425 volts, which means the current must have risen from 1 ma to nearly 1.1 ma. If the shunting resistor, connected to the terminals, is equal to the meter resistance, this current will be equally divided between them, so the reading will be about 0.55, instead of 0.5 as would be the case according to the statement usually given. To produce half-scale reading a resistor of slightly lower value must be used.

In practice it can be shown that half-scale reading is produced when the external resistance connected is equal to the combined parallel resistance of the meter with any internal shunts, and also with its series feed resistor, as viewed from the terminals of the instrument (regarding the battery resistance as zero).

Now we have the basic requirements for producing an instrument whose accuracy is not to be too dependent on the battery voltage.

The adjustment for full scale, which is zero ohms for the series type or infinity for the shunt type, must adjust the balance of current in the circuit associated directly with the meter movement, without appreciably altering the internal resistance as seen from the instrument terminals.

It has already been shown that using a higher battery voltage improves the possibility for the series instrument. This is true also in the case of the shunt instrument, because the series resistor, although variable, is then always much

higher than the meter's own resistance.

Whatever circuit is used, its range is somewhat limited compared with the wide range of resistance values encountered in practice. To extend the useful range of an instrument it would be good to have a multirange ohmmeter with an accuracy similar to that achieved by multirange testers for voltage and current. Fig. 4 shows a circuit the author has designed, which has the following useful features:

1. Circuit simplicity—a minimum of special resistors that have to be adjusted to fit the scale.
2. A minimum number of contacts in the switching arrangement.

The latter is particularly important for the lower range readings, because contact resistance can often ruin a reading. In this instrument the number of switch contact decks is reduced by using a strap across the high-resistance test terminals for the ranges using the shunt ohmmeter principle.

A single variable resistor is used for zero adjustment. Some may feel that it would be an advantage to have independent zero adjustment for each range, so that changing the range does not make it necessary to readjust for zero. Circuits devised to do this usually have the disadvantage that each adjustment interferes slightly with the others, unless extra switching is employed to disconnect from the circuit the variable resistors not in use. This would increase the number of switch contacts necessary.

In this circuit a variation from that of Fig. 2 is used for the zero adjustment, to enable the same variable resistor to serve all ranges, and to avoid the use of low-value variables, which can cause poor reliability.

With the 3-pole switch in the "× 10" position, the instrument has a center-scale reading of 10,000 ohms, using the HIGH R TEST terminals. To obtain this the series resistor R7 should be just under 10,000 ohms. A resistor of 10,000 ohms 1% should serve here, trimmed, if desired, by setting the instrument to give center-scale reading with a standard resistor of 10,000 ohms. The instrument shunt has a fixed value of

TEST INSTRUMENTS

470 ohms (R4), while the zero adjuster is a series resistor (R2) of 100 ohms maximum, that varies the voltage drop across the meter branch at full-scale deflection and so varies the current bypassed by the 470-ohm shunt.

The other two switch positions—the direct reading and the “ $\div 10$ ” position—give the instrument center-scale readings of 1,000 ohms and 100 ohms respectively. The standard resistors for these ranges are also about 1,000 ohms and 100 ohms (R8 and R9). One per cent resistors can be used here, being trimmed to the correct value by obtaining a center-scale reading with a resistance standard of 1,000 ohms and 100 ohms respectively. For these ranges, the meter shunts are R5 and R6, which also serve as resistance standards for the two lowest ranges, using the shunt-ohmmeter principle. For series-ohmmeter operation, the zero adjustment provides—at full-scale deflection—a path for the current exceeding the 1 ma that goes through the meter. On the “ $\div 10$ ” position the total current at full-scale deflection is about 135 ma, so, to conserve battery life, the instrument should never be left in this position for longer than is necessary to take a reading.

The meter that forms the basis of the instrument shown has a resistance of 150 ohms. This was chosen to allow the circuit to be applied to use an old type of meter with some useful life still left in it. Modern meters of 1-ma rating have a lower resistance, or alternatively, for the same resistance a more sensitive meter can be obtained. The limiting factor for the high range is the volt drop necessary to give full scale deflection through 10,000 ohms. With a more sensitive meter—for example a 500-microampere job—the same circuit can be used with only half the battery volts (say 6 volts' worth) and much longer battery life. To use the same circuit with a 1-ma meter of lower resistance value, the simplest method is to build out the meter resistance to suit the values given, so the effective resistance of the meter with a series resistor comes to 150 ohms. This avoids the necessity of recalculating all the circuit values. If a 200-microampere meter should be handy, the circuit could be revised slightly to make it work on only 3 volts' worth of battery. The revision would consist of increasing the resistance values of the zero adjuster and associated switch connections somewhere between two and five times. R4 would also need increasing. The aim in selecting these values is to minimize the readjustment necessary when the range is changed.

For the shunt-connected ranges, giving center-scale readings of 10 ohms and 1 ohm, the positions marked DIR and “ $\div 10$ ” are used, with the HIGH R TEST terminals strapped together to give full-scale reading. The resistance to be measured is then connected to the LOW R TEST terminals.

To obtain the correct values for the

“standards” R5 and R6 on these ranges: R5 is calculated so that with the average full-scale setting of R2, the combined resistance made up of R5, R8, and the meter branch all in parallel is 10 ohms. This procedure is simpler for R6, because the other branches, R9 and the meter branch, are both much higher in value than 1 ohm—the required combined value in this case, for absolute accuracy. If the low-value resistors R5 and R6 are not available, they can be made up of resistance wire.

As with the series arrangement, the lowest range should be used only long enough to check for full-scale deflection and then to measure the required resistance. Carelessness about this precaution will quickly flatten a set of batteries.

This can be overcome, for bench work, by using a rectified supply from the power line. A step-down transformer to give an output voltage of 15 to 20, using a metal rectifier to give the right d.c. output, will provide an energizing supply for this ohmmeter. The method of zero adjustment will still render it practically independent of supply-voltage variations. Values of R1, R2, and R3 may need adjusting to suit the exact voltage used; also the values of R7, R8, and R9 may need modifying slightly, due to the effective internal resistance of the supply. This can be calculated by measuring the reduction in d.c. output voltage from the supply when the maximum full-scale current on the lowest range is drawn from it. Dividing this current value into the drop in output voltage it produces will give an effective internal resistance. For example, if the current is 140 ma, and the voltage drops from 16 to 13.2, a difference of 2.8, the internal resistance is 2,800 divided by 140, or 20 ohms. This resistance should be subtracted from the values given for R7, R8, and R9, particularly the last, to keep the center-scale reading correct.

Using the convenient center-scale reading of multiples of 10, the instrument will have a scale of the type shown in Fig. 5, the scale marked HIGH R TEST being used for the readings using series-ohmmeter connections on the upper three ranges and the scale marked LOW R TEST for readings on the shunt-ohmmeter circuit used for the two lower ranges, when the HIGH R TEST terminals are strapped together.

The strap for the HIGH R TEST terminals can be made from a metal strip, with two holes drilled to fit the terminal spacing. One of these holes is then slotted out sideways, so the strap can be held by the other hole to one terminal, being clamped on the remaining terminal, or released, according to whether the LOW R TEST or HIGH R TEST is being used.

With television, high-fidelity audio, and other electronic equipment demanding closer-tolerance resistors, this high-accuracy ohmmeter is a valuable test instrument. END

MINIATURE AUDIO-FREQUENCY TEST OSCILLATOR

By I. QUEEN

THIS tiny oscillator is self-contained (except for load) and is mounted inside a plastic box only $2\frac{1}{4} \times 1\frac{1}{4} \times \frac{7}{8}$ inches. The heart of the circuit is a Raytheon transistor, type CK722. It is powered by one AA dry cell. Output is strong enough to provide a good head-phone signal.

Audio feedback is maintained by a “Sub-Ouncer” 3:1 ratio audio transformer. Any other transformer may be used but will require considerably more space. If the “Sub-Ouncer” is used, follow the terminal connections specified. If another type is used, connect the low-impedance winding in the base circuit, the high-impedance winding in the collector circuit. If no oscillations are heard, try reversing connections to one of the windings.

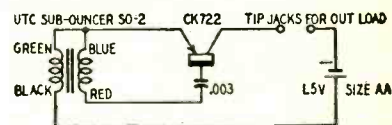

The frequency is determined by the particular transformer used and the capacitor in series with the base. With the circuit and constants shown in the figure the frequency is 1,500 cycles. To change the tone use a different value of capacitor. The frequency will vary (upwards) to some extent when the oscillator is used near a strong incandescent lamp. For example, the frequency will rise to about 2 kc if a 40-watt lamp is brought a few inches from the oscillator. A fluorescent lamp does not cause a perceptible change. Sunlight, even indirect, makes a considerable difference in the frequency. Evidently the transistor is slightly photosensitive.

The oscillator was constructed to see how compact a *reliable* instrument could be. It is more than a mere toy. It may be used to test a.f. amplifiers or for long-distance CW communication by wire. It may be used as a source of known frequency (if shielded from light). It is easily carried about in a pocket to permit indulging in code practice during lunch hours or recess, or other spare periods.

The efficiency of the CK722 transistor is astounding. In this circuit it consumes 5 microwatts. This is about .005 of 1% as much power as required by a sensitive high-frequency buzzer, or a low-power tube oscillator.

This oscillator contains an unusual degree of miniaturization. With an extremely small cell for power, the CK722 transistor, and the UTC subouncer SO-2 transformer (10,000-ohm primary, 90,000-ohm secondary), the unit can be easily handled. END

Distortion

TOTALIZER

By C. W. PALMER

*An excellent instrument
for a rapid check
of audio-amplifier distortion*

DISTORTION measurement is a very important part of audio servicing. An amplifier can hardly be said to have been serviced thoroughly without some measurement of distortion. The distortion totalizer is a relatively simple device for measuring total harmonic distortion. It is basically a twin-T null network that suppresses the fundamental frequency, leaving only the harmonics, which can then be compared to the amplitude of the fundamental to give the percentage of harmonics.

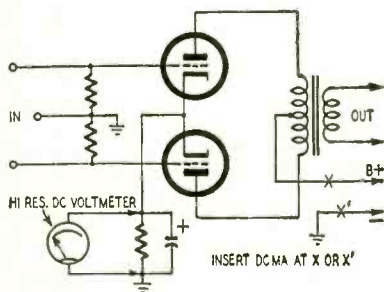

Fig. 1—Diagram shows method for checking class-A amplifier distortion.

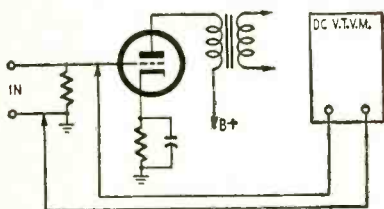

Fig. 2—Distortion check with v.t.v.m.

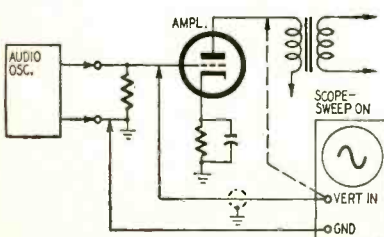

Fig. 3—Setup for indicating distortion.

In its simplest form, distortion is the disfiguring of a signal as it passes through a circuit. When distortion is present, the tone from the amplifier is combined with one or more higher tones called harmonics, which were not in the original signal. This change causes the amplified tone to sound harsh or unnatural.

The service technician will be most concerned with the second, third, and fourth harmonics, as these are much stronger and more troublesome than the higher-order harmonics. The second harmonic can be considerably reduced by using a push-pull output stage in the amplifier. Incidentally, this is one of the principal reasons why push-pull is so popular in the power stages of modern amplifiers.

Measuring distortion

Harmonics can be measured separately and the percentage of each figured against the voltage of the fundamental. The percentages can then be combined to give a total harmonic percentage. A second method is to measure all the harmonics together, giving a total harmonic figure. But this does not tell the relative strength of the individual harmonics.

Each harmonic can be measured and compared separately in the following manner:

$$\% \text{ distortion (of harmonic)} = \frac{E_2}{E_1} \times 100$$

where E_1 is the voltage of the fundamental, and E_2 is the voltage of the individual harmonic.

Each separate harmonic percentage must be figured in the same manner, but they cannot be simply added together to get the total harmonic distortion. To do this, we must square each percentage, add the squares, and then find the square root of this total. The following formula is used:

$$\text{Distortion (total)} = \sqrt{D_2^2 + D_3^2 + D_4^2, \text{ etc.}}$$

where $D_2, D_3, D_4, \text{ etc.}$, are the respec-

tive harmonic percentages which may be measured—usually at least to the fifth harmonic.

To measure each harmonic voltage individually, a wave analyzer is needed. This is a laboratory instrument which can be tuned like a radio receiver to each harmonic and indicates the voltage of each.

More simple and certainly less expensive is a method of checking total distortion. This will be described in greater detail along with details for making the special apparatus needed.

Qualitative tests

The simplest test that can be made for distortion is to listen to the output of an amplifier, but this is probably the least reliable. The distortion must be considerable before even a trained ear can distinguish it (the ear will respond to distortions of something over 5%). In addition to this there are all the mental and physiological conditions that mask the true result, making the ear an extremely unreliable measuring instrument.

Electrical tests that are indicative of distortion can be made in some cases. In class-A amplifiers the plate current remains steady when a signal is applied or removed, if there is no distortion. A milliammeter inserted in the $B+$ or $B-$ lead to the amplifier will serve as an indicator. A high-resistance voltmeter connected across the cathode resistor of

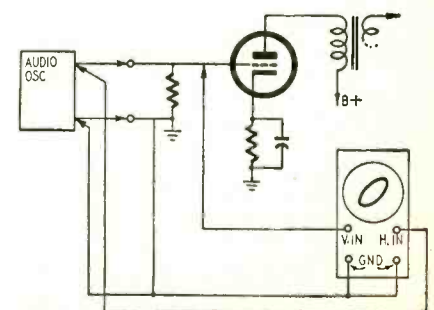
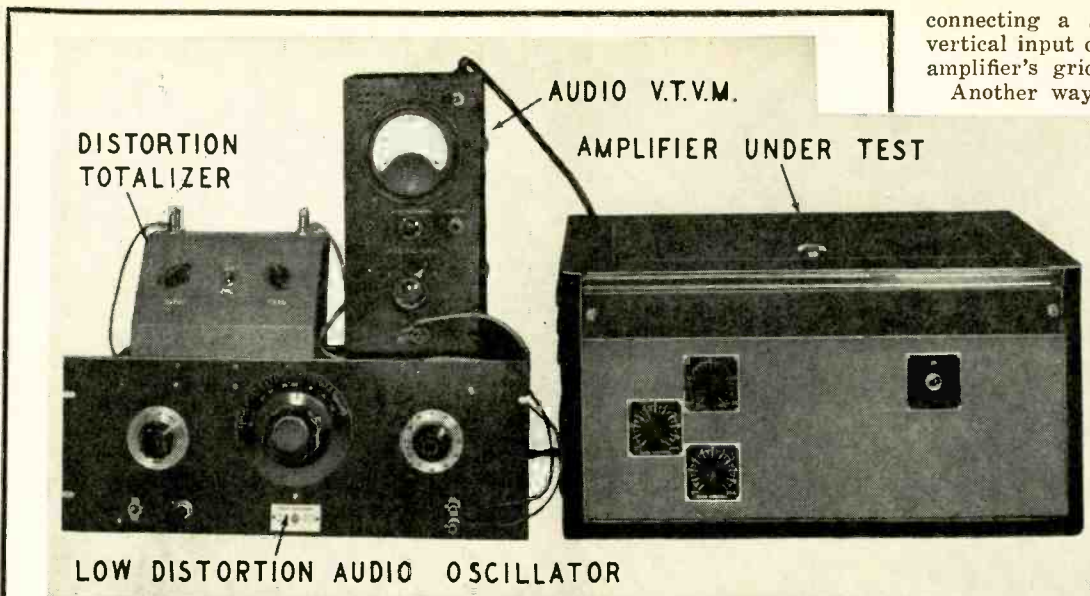

Fig. 4—Fig. 3 setup using audio sync.

TEST INSTRUMENTS



connecting a shielded lead from the vertical input of the oscilloscope to the amplifier's grid or plate. See Fig. 3. Another way to use the oscilloscope

Test setup for distortion measurement.

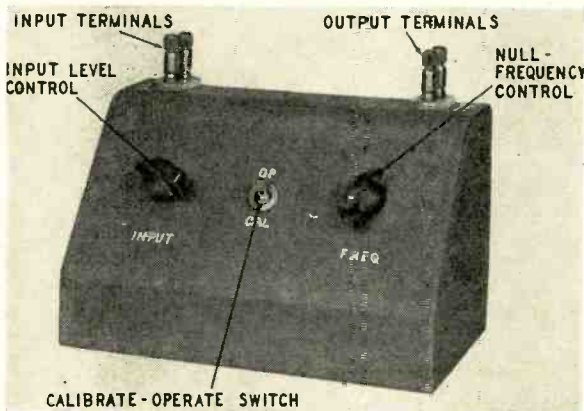

Controls indicate simplicity of operation.

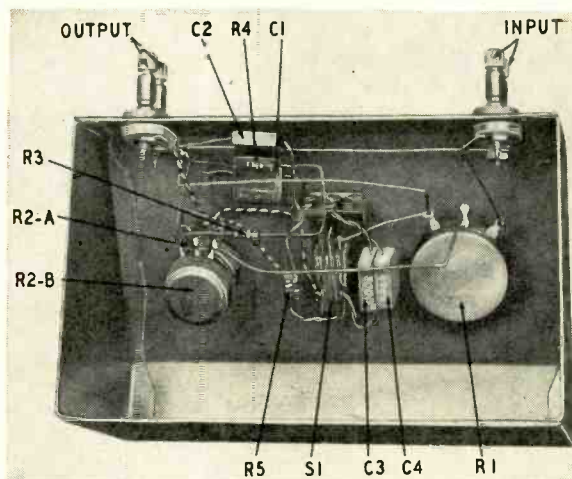

Internal view of distortion totalizer.

the amplifier stage being checked also will indicate a change in plate current (the voltmeter should not show a change in indicated voltage when a signal is applied or removed). See Fig. 1.

This method cannot be used on class B or class C (transmitter) amplifiers because grid current flows part of the time, and plate current varies with signal.

Another method that can be used on

all class-A1 and AB1 amplifiers is to connect a vacuum-tube d.c. voltmeter from grid to ground. A negative voltage will be indicated equal to the negative grid bias voltage. This should not fluctuate, and any variation is indicative of distortion. See Fig. 2.

The oscilloscope with an audio oscillator having good waveform, can be used to indicate distortion by connecting the oscillator to the amplifier input and

is to connect it as above but do not turn on the horizontal sweep. Instead, connect a shielded lead from the horizontal terminals of the scope to the audio oscillator output as shown in Fig. 4. Now the image on the screen will look somewhat like the various patterns in Fig. 5. With no phase shift, a straight diagonal line would be seen on the scope screen (Fig. 5-a); however, most amplifiers introduce some phase shift so that a more common image is the diagonal ellipse in Fig. 5-b. Distortion is indicated when the ellipse becomes irregular or broken in shape as shown in Fig. 5-c and 5-d. This method is described in the article beginning on page 58 of this issue.

Quantitative tests

The qualitative tests have their use in engineering, but for the service technician who wants a quick over-all look, the quantitative test is preferable.

In this type of test, a comparison is made between the signal at the output of the amplifier (or any stage)—with the oscillator fundamental present, and then with it suppressed.

The theory of operation depends on a dual-input parallel-T null network that was developed by C. F. White and K. A. Morgan of the Naval Research Laboratory and presented at the 8th National Electronics Conference in

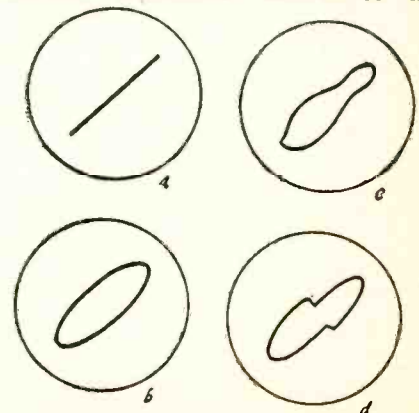

Fig. 5—Patterns indicate distortion.

TRACKING DOWN HORIZONTAL INSTABILITY

Part I—The
problems of
analysis
and location

By CYRUS GLICKSTEIN

HORIZONTAL instability in TV may appear in several ways:

1. Bending or pulling
2. Touchy horizontal hold
3. Tearing
4. Horizontal jitter
5. Intermittent loss of horizontal sync.

The fault usually arises from a defect in the video strip, sync section, horizontal a.f.c. circuit, or horizontal sweep section (Fig. 1). Instability may arise also from interference signals, generated either internally or externally. A horizontally stable picture requires four basic ingredients: good horizontal sync pulses (sufficient amplitude and correct shape); correct waveform in the horizontal sweep circuit with respect to amplitude, shape, and approximate frequency; normal action in the horizontal a.f.c. circuit to lock in the horizontal oscillator at the correct frequency; absence of internal or external interference to upset synchronization.

To provide good horizontal sync pulses both the video strip and the sync section must be operating normally. For correct waveform the horizontal sweep section and the horizontal a.f.c. circuit must be functioning correctly.

Localizing the trouble

It may be helpful to list the most common causes and symptoms of trouble in each section. Very often these symptoms provide clues which help localize the trouble quickly. It should be kept in mind that older sets occasionally may develop multiple troubles.

1. Video Strip. Consists of the tuner, the video i.f. section, video detector, video amplifier, and the C-R tube. Composite video signals, consisting of both video information and sync pulses, pass through the video strip. As a result, video-strip troubles may cause not only horizontal instability but also additional picture defects.

Overloading. Too strong a signal at the antenna terminals or a failure in the a.g.c. system can cause overloading. This shows up as excessive contrast.

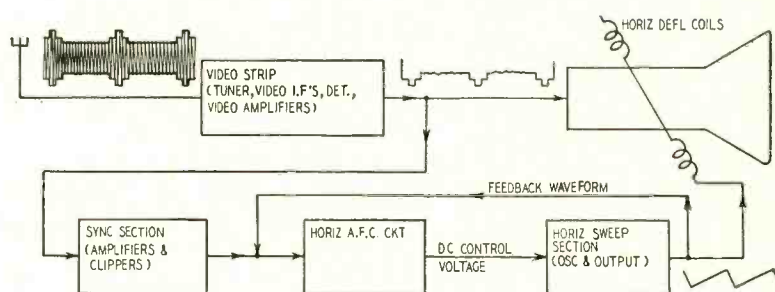

Fig. 1—Block diagram shows partial layout of a typical TV receiver.

Misalignment of the r.f. or i.f. sections. Shows up as a weak, smeared, or blurry picture. This condition usually produces weak sync pulses.

Hum pickup. Sixty-cycle hum pickup may result from leakage from the heater to other elements in any tube in the video strip. This produces a 60-cycle hum modulation of the picture (Fig. 2). Other types of hum pickup are 60-cycle or 120-cycle ripple in the B+ line to the video strip and 15,750-cycle pickup in the a.g.c. system, due to poor filtering of the a.g.c. output voltage. These also hum-modulate the picture with a characteristic pattern.

Nonlinear operation. A defective component such as a leaky coupling capacitor may cause nonlinear operation in a given stage, resulting in horizontal instability and a degraded picture.

External interference. Heavy noise pulses, ignition, diathermy, and other types of external interference which may affect horizontal synchronization usually show a characteristic noise pattern on the screen.

Internal interference. Internally generated interference—such as pickup from the sweep circuits—may feed into the video strip, the sync section, or the horizontal a.f.c. circuit. Horizontal sweep pickup in the video section may cause one or more vertical lines in the picture or raster as well as horizontal instability. Horizontal sweep pickup in the sync or a.f.c. circuit results only in unstable sync.

2. Sync section. Sync circuit defects

usually affect sync horizontally and vertically. Very often, the defect is more pronounced in a vertical direction, because of the stabilizing effect of the horizontal a.f.c. circuit. However, 60-cycle leakage between heater and cathode in one of the sync tubes may not greatly affect vertical operation but may still show up as a horizontal fault—horizontal bend. Hum originating in this section (or in the a.f.c. or horizontal sweep section) produces bend but does not hum-modulate the video information (Fig. 3). That is, there is no black stripe across the picture or raster. Generally, horizontal trouble originating in the sync circuit can be spotted by a check of the vertical hold control. If, in addition to horizontal instability, the vertical hold control is touchy and has less than the normal hold-in range, while video information is normal, a defect in the sync section is indicated.

3. Horizontal a.f.c. section. Horizontal a.f.c. circuit troubles usually affect horizontal synchronization only and have no effect on the vertical sweep. These troubles include 60- and 120-cycle pickup, vertical sweep coupling into the horizontal a.f.c. circuit, misalignment, and faulty operation due to component breakdown.

Hum pickup (60- or 120-cycle) in the a.f.c. circuit can cause a bend in the picture (Fig. 3). This will also show up on a blank channel as a bend along the side of the raster, if the raster is moved by the horizontal centering con-



Fig. 2—Sixty-cycle hum modulation.



Fig. 3—Horizontal bend due to cathode-heater short in sync amplifier.

trol or other centering adjustment so the side is visible. Since this can be caused also by hum pickup in the horizontal sweep circuit, one method of localization is to remove the a.f.c. tube and note the effect on the side of the raster.

Misalignment of the a.f.c. circuit can cause any of the symptoms of horizontal instability. In certain cases, it is difficult to determine whether the trouble is originating in the a.f.c. circuit or in the horizontal sweep section.

4. Horizontal sweep circuit. Faults in the horizontal sweep circuit which cause horizontal instability often cause other troubles at the same time—such as vertical lines on the picture or raster, horizontal foldover, or a dim raster. Most of these faults are seen on the raster (blank channels) as well as on the picture (active channels).

Some types of horizontal instability, such as touchy horizontal hold or an intermittent loss of horizontal sync, originating in the horizontal sweep section are noticeable only when there is a picture on the screen. Instability originating in this section may arise from incorrect settings of the horizontal frequency controls (hold, lock, etc.), component breakdown, changed values,

or incorrect values in the horizontal oscillator or output stages.

Trouble-shooting procedure

Although horizontal instability may originate in several sections of the receiver, the cause is usually not too difficult to track down if a systematic trouble-shooting procedure is followed.

As usual, the first problem is to find the defective section. This is usually solved as follows: Check the picture on each active channel and the raster on a blank channel. Then vary the pertinent controls to determine their effect on the picture. Check the effect of changing lead dress at critical points. If necessary, check waveforms.

Suppose, for example, a broad black horizontal stripe (60-cycle hum) is seen on the picture. Checking the raster on a blank channel will help localize the source of the hum. A 60-cycle signal by itself cannot pass through the r.f. and i.f. stages, since these stages are not designed to pass such low frequencies. The hum can pass through these stages only by modulating the incoming signal. On the other hand, a 60-cycle hum signal can be amplified directly in the video amplifier stages. Therefore, if the hum is noted on every

active channel, but not on a blank channel, it must arise from a fault in the tuner or video i.f. section. If the hum is also visible on the screen when a blank channel is tuned in, it must originate in the video detector or video amplifier stages.

In the same way, if a vertical line is seen on active channels only, it indicates a possible defect in the a.g.c. filter system. If the vertical line is seen on blank channels also, this indicates a fault in the horizontal sweep circuit, horizontal sweep pickup in the video amplifier stages, or input to the C-R tube.

Another step in localizing the defective section is to check the action of the pertinent controls. The most important are: horizontal hold, vertical hold, contrast, brightness, fine tuning, and horizontal lock. Additional controls which should be checked in receivers having them are the a.g.c. and the noise compensator (or equivalent) controls.

Each type of horizontal a.f.c. circuit has a certain hold-in range, varying from about one-quarter to full rotation of the horizontal hold control. Although this may vary somewhat in different models, the range is fairly uniform for each type of a.f.c. circuit. In checking horizontal instability, the horizontal hold should be varied to determine how much of the normal hold-in range is obtainable. Then the vertical hold should be checked. If the hold-in range of both the horizontal and vertical hold controls is abnormally low and the picture information is too light, too dark, or otherwise abnormal, the trouble is most likely in the video strip or in the incoming signal. If the hold-in range of both controls is abnormal while picture information is normal, the trouble is most likely in the sync section. If the vertical hold-in range is normal and the picture information is normal, while the horizontal hold has much less than the normal range, the trouble is most likely in the horizontal a.f.c. or horizontal sweep circuit.

In this last case, operating the horizontal hold control may localize the trouble further. If the horizontal hold control is very touchy throughout its range, but each readjustment temporarily returns the picture to a synchronized condition, while the vertical hold is normal, the trouble is very likely in the a.f.c. circuit. If the horizontal hold barely reaches a synchronized position at the end of its range, the a.f.c. circuit may need realignment, or else there has been a change in component value in the horizontal oscillator circuit.

To check whether a.f.c. realignment is necessary, leave the horizontal hold in the center of rotation. Turn the rear panel (or top-of-chassis) horizontal lock control a little in either direction. If some improvement is noticed, complete the regular alignment procedure for that type of a.f.c. system. If no improvement is noted, return the control to its original setting and continue trouble-shooting.

TELEVISION

Rotating the contrast control indicates whether the picture contrast has the normal range of variation and whether the video strip is functioning correctly. When there is a smeared picture or one with poor definition which cannot be cleared by rotating the fine-tuning control, then r.f. or i.f. misalignment or a breakdown in the video strip is indicated.

Rotating the a.g.c. control may eliminate an overcontrasted condition due to overload. In some receivers, misadjustment of the noise cancellation or equivalent control can cause a dark picture with poor sync action. In checking these two controls, turn them a little to either side of the original setting to determine if the condition improves and if the control is operating normally. If there is no improvement, return the control to the original setting and check further.

If control checking is completed and results are inconclusive, check whether poor lead dress is causing the trouble. Horizontal jitter or tearing can be caused by interaction between leads. Dress leads as far away from each other as possible without bringing them close to other circuits which may introduce interference. Take special care with: cathode (grid) lead of picture tube and deflection yoke cable, antenna lead-in to the tuner, and damper tube leads.

When the defective section or sections are localized, the next step is changing tubes. If the trouble is not due to a bad tube, the fault can be localized to a particular stage by signal tracing with an oscilloscope.

Using the oscilloscope is especially useful when all other checks prove inconclusive and it is not clear just where the trouble is originating. Signal tracing with an oscilloscope can usually localize the trouble not only to the section but to the particular stage that is defective. Once the trouble has been localized it can then be pinpointed by standard voltage and resistance measurements. With a little practice this procedure will prove highly profitable.

Check the waveform at each stage to determine at what point the output becomes defective, starting at the video detector and going on to the video amplifier, sync section, horizontal a.f.c., and horizontal oscillator stages. At the stage where the waveform becomes defective, check further with voltage and resistance measurements. This shows up the fault in most cases. When these measurements do not indicate the trouble, it is usually caused by an open capacitor or one that has changed value, so try substituting capacitors. In some cases, a coil or transformer with a few turns shorted or with a broken ferrite core may show normal voltage and resistance readings but may not function properly. In such cases, it may be necessary to substitute parts to determine the trouble. (TO BE CONTINUED)

NEW TELEVISION STATIONS

(List of stations which started operation since our last January list was printed)

Alaska			North Carolina		
KTVB	Anchorage	11	WAYS-TV	Charlotte	36
Arkansas			WMFD-TV	Wilmington	6
KARK-TV	Little Rock	4	WNCT	Greenville	9
KATV	Pine Bluff	7	North Dakota		
California			KFYR-TV	Bismarck	5
KBID-TV	Fresno	53	Ohio		
KQED	San Francisco	9	WSTV-TV	Steubenville	9
KSAN-TV	San Francisco	32	Oklahoma		
KTVU	Stockton	36	KCEB	Tulsa	13
Colorado			KTEN	Ada	10
KFXJ-TV	Grand Junction	5	KWTV	Oklahoma City	9
KOA-TV	Denver	4	Oregon		
Florida			KVAL-TV	Eugene	13
WDBO-TV	Orlando	6	Pennsylvania		
WINK-TV	Fort Myers	11	WARM-TV	Scranton	16
WITV	Fort Lauderdale	17	WQED	Pittsburgh	12
WJDM	Panama City	7	WSEE	Erie	35
WJHP-TV	Jacksonville	36	Puerto Rico		
Georgia			WAPA-TV	San Juan	4
WALB-TV	Albany	10	WKAQ-TV	San Juan	2
WRDW-TV	Augusta	12	Rhode Island		
WTOC-TV	Savannah	11	WNET	Providence	16
Hawaii			South Carolina		
KULA-TV	Honolulu	4	WAIM-TV	Anderson	40
Idaho			WFBC-TV	Greenville	4
KID-TV	Idaho Falls	3	Tennessee		
Illinois			WDEF-TV	Chattanooga	12
WBLN	Bloomington	15	Texas		
WDAN-TV	Danville	24	KBMT	Beaumont	31
WSIL-TV	Harrisburg	22	KMID-TV	Midland	2
Indiana			KRGV-TV	Weslaco	5
WSJV	Elkhart	52	KVDO-TV	Corpus Christi	22
Iowa			Virginia		
KGLO-TV	Mason City	3	WBTV-TV	Danville	24
WHO-TV	Des Moines	13	West Virginia		
Louisiana			WJPB-TV	Fairmont	35
KSLA	Shreveport	12	Wisconsin		
Maine			WEAU-TV	Eau Claire	13
WCSH-TV	Portland	6	WHA-TV	Madison	21
WGAN-TV	Portland	13	WNAM-TV	Neenah	42
WLAM-TV	Lewiston	17	Wyoming		
Maryland			KFBC-TV	Cheyenne	5
WBOC-TV	Salisbury	16			
Massachusetts					
WMGT	Adams-Pittsfield	74			
Michigan					
WKAR-TV	East Lansing	60			
WNEM-TV	Bay City-Saginaw	5			
WWTW	Cadillac	13			
Minnesota					
KDAL-TV	Duluth-Superior	3			
WDSM-TV	Duluth-Superior	6			
Mississippi					
WCOC-TV	Meridian	30			
WLBT	Jackson	3			
WSLI-TV	Jackson	12			
Missouri					
KOMU-TV	Columbia	8			
Montana					
KFBB-TV	Great Falls	5			
Nevada					
KHOL-TV	Kearney	13			
New Hampshire					
WMUR-TV	Manchester	9			
New Jersey					
WRTV	Asbury Park	58			
New York					
WKNY-TV	Kingston	66			
WTRI	Schenectady	35			

The following stations, which appear in the list on page 80 of the January, 1954, issue, have since gone off the air:

KRTV	Little Rock, Ark.	17
KDZA-TV	Pueblo, Colo.	3
WKLO-TV	Louisville, Ky.	21
KFAZ	Monroe, La.	43
WBKZ-TV	Battle Creek, Mich.	64
WTAC-TV	Flint, Mich.	16
KACY	Festus-St. Louis, Mo.	14
KCTV	Kansas City, Mo.	25
KFOR-TV	Lincoln, Nebr.	10
WPPG-TV	Atlanta City, N.J.	46
WBES-TV	Buffalo, N.Y.	59
WECT-TV	Elmira, N.Y.	18
WIFE	Dayton, O.	22
KETX	Tyler, Tex.	19
WACH	Newport News, Va.	33
WOSH-TV	Oshkosh, Wisc.	48

The following stations have changed channels: WRGB, Schenectady, N.Y., from channel 4 to 6; WOOD-TV, Grand Rapids, Mich., from channel 7 to 8. KEYL, San Antonio, Texas, channel 5, has changed its call letters to KGBS-TV. KGBS-TV, Harlingen, Texas, channel 4, has changed its call letters to KGBT-TV.

COLOR TV CIRCUITS

By KEN KLEIDON AND PHIL STEINBERG*

Part III—Burst amplifier, color oscillator, and control circuits

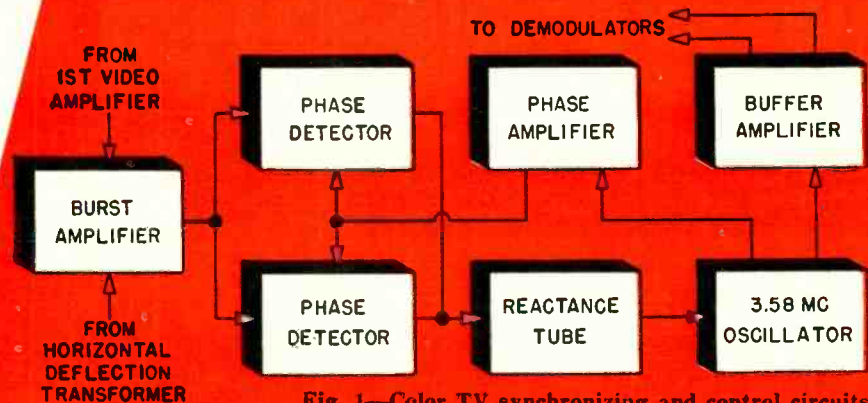

Fig. 1—Color TV synchronizing and control circuits.

THE circuits discussed in the two previous articles were common to any color receiver regardless of the type of picture tube used. The color sync channel, consisting of the burst amplifier, phase detector, reactance tube, oscillator, phase amplifier, and buffer amplifier (see Fig. 1), is basically the same whether the three-gun dot type (RCA or CBS) or the single-gun strip type (Lawrence) picture tube is employed.

As mentioned in the last article (Part II) the composite color video signal from the video detector is coupled to the first video amplifier, and then separated and fed to four different circuits. The signal we are interested in now is the one coupled to the burst amplifier. The other three signals were discussed in the previous article.

The composite color video signal contains the color burst on the horizontal blanking pedestal following the horizontal sync pulse as shown in Fig. 2. The color burst is nothing more than a synchronizing signal provided to control the phase and frequency of the color oscillator. It can be considered as additional sync information similar to the horizontal sync pulse, but its frequency and phase is accurately controlled at the transmitter. This color-burst signal is approximately 9 cycles of a continuous sine wave whose frequency is 3.579545 mc (approximately 3.58 mc). The 3.58-mc tuned transformer in the plate circuit of the first video amplifier serves as a pick-off coil for the color-burst signal which is applied to the burst amplifier and—by acting also as a 3.58 mc trap with respect to the monochrome or luminance take-off from either plate or cathode of the first video amplifier—keeps the color burst and subcarrier (color information) out of the luminance channel.

The color-burst signal is shown (see Fig. 2) in the composite color video signal and at the output of the 3.58 mc transformer. Actually some chromi-

nance or color information will also appear at the output of the 3.58-mc tuned transformer, as the color subcarrier is at the same frequency as the color-burst signal. To prevent this, the burst amplifier is *gated*—allowed to conduct only during the horizontal blanking period—by a pulse from a winding on the horizontal deflection transformer. Since the color-burst signal occurs during the horizontal blanking period (Fig. 2) and the burst amplifier is gated, only the color-burst signal will be amplified by the burst amplifier. This action is very similar to that of a gated a.g.c. circuit, where a pulse from the horizontal deflection transformer allows the a.g.c. tube to conduct only for the period corresponding to the horizontal sync pulse. The operation here is the same, only the pulse is delayed slightly by a resistance-capacitance network in the cathode circuit so the pulse will occur at the time of the burst. Applying a negative pulse to the cathode has the same effect as a positive pulse applied to the plate of an a.g.c. tube. Between pulses the tube is held at cutoff by a positive bias voltage applied to the cathode by a resistor network connected to B plus.

Referring to Fig. 1 again, the color-burst signal from the burst amplifier is applied to the phase detectors which feed a reactance tube which in turn controls the color oscillator. One output from the color oscillator feeds the I and Q demodulators through a buffer stage while the other output is fed back to the phase detectors through the phase amplifier. The operation and function of the phase detectors, oscillator, and phase amplifier are similar to that of the horizontal oscillator and control circuit in many monochrome and color receivers. Two sync pulses of opposite polarity and equal magnitude are usually derived from the incoming horizontal sync, and are fed to the phase detectors (a.f.c. diodes) which compare these pulses to a signal fed back from the horizontal oscillator. The discriminator action of the phase detectors pro-

duces a d.c. bias voltage when the oscillator is slightly off frequency and applies this d.c. bias voltage to the oscillator for frequency correction.

The phase detector input transformer in the plate circuit of the burst amplifier (Fig. 3) is tuned to the burst frequency (3.58 mc) and provides the two sync signals at 3.58 mc of equal magnitude and 180 degrees out of phase (opposite polarity) to the phase detectors by the split secondary winding. The signal from the oscillator coupled through the phase amplifier is compared to the incoming color-burst signals and is used as a reference so that any phase difference results in a d.c. bias voltage applied to the reactance tube. The polarity of the d.c. voltage depends on whether the oscillator signal is leading or lagging the reference burst signal and the magnitude is dependent on the degree of lead or lag.

The d.c. bias voltage is applied to the reactance tube which controls the frequency of the oscillator. The reactance tube, for simplicity, can be considered a variable capacitor in parallel with the crystal of the oscillator. The resulting or effective capacitance presented by the reactance tube varies according to the polarity and magnitude of the d.c. bias voltage from the phase detectors.

The crystal-controlled oscillator is connected as a cathode follower for the

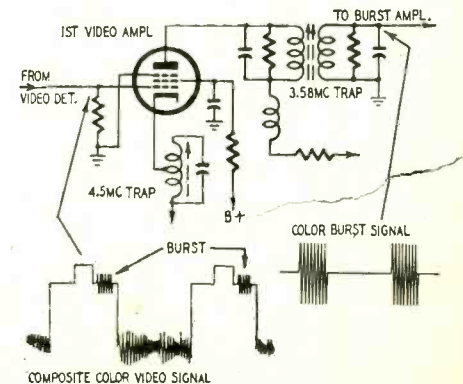

Fig. 2—The burst amplifier signals.

*Raytheon Manufacturing Company, Television and Radio Division.

TELEVISION

circuit shown and generates a 3.58-mc signal which is applied to a demodulator. The function of the color oscillator is identical to that of a local oscillator in a radio receiver. The demodulator can be considered similar to the first detector or converter in a radio receiver. The r.f. signal in a radio receiver is coupled to the converter stage along with the signal from the local oscillator. The difference frequency (local oscillator frequency minus r.f. signal frequency) is coupled to the i.f. amplifier. The chrominance signal or color information (similar to the r.f. signal) from the bandpass amplifier is coupled to the demodulator (similar to the converter stage) along with the signal from the color oscillator (similar to the local oscillator). The resulting signal (similar to the difference frequency) from the output of the demodulator is coupled to an amplifier.

From the above it can be seen that



A typical color sync crystal.

the only function of the color oscillator is to generate two signals at the same frequency (3.58-mc) and 90 degrees out of phase with each other, to be applied to the demodulators. Due to the composition of the chrominance signal, two demodulators are required, necessitating two signals—90 degrees out of phase with each other—from the color oscillator. This is accomplished in the buffer amplifier by transformer T4.

As mentioned previously, the color oscillator is crystal controlled. The color television standards are precise, so

the frequency and phase tolerance of the color oscillator are extremely critical. To meet these critical tolerances a crystal oscillator is used, as it has a very high Q so that once it is locked in phase and frequency it is very stable and difficult to disturb. A crystal oscillator may be something new to the average television service technician unless he is an amateur or has had experience with transmitters. The photograph shows a typical crystal used in a color oscillator. It is 5/16 by 11/16 by 3/4 inch in size and the operating frequency 3,579.545 kc. (3.58 mc.) is usually stamped on its top side. It is equivalent to a tuned circuit with a very low energy loss due to the low resistance value of R and so presents a very high Q.

Reviewing the over-all operation of the color oscillator and control circuits, assume that the oscillator is slightly off frequency. Since one of the outputs from the oscillator is coupled back to the phase detectors through the phase amplifier (an amplifier tuned to 3.58 mc) a phase difference will result between the burst and oscillator signals. This phase difference will cause a change in the d.c. bias voltage applied to the reactance tube, which will change the effective capacitance across the oscillator to change frequency and phase to correspond to that of the burst signal. This elaborate control network for the color oscillator is necessary as a frequency tolerance of not more than 11 cycles deviation is allowable. False color information will result with even the slightest change in the frequency of the color oscillator.

The other output from the oscillator is coupled to a buffer amplifier. In the plate circuit a quadrature transformer (T4 in Fig. 3) is used to obtain two signals 90 degrees out of phase (one signal lagging the other by quarter of a sine-wave cycle) for application to the demodulators. The demodulators, to be covered in our next article, beat the chrominance signal with the two signals from the oscillator to obtain the three color signals (red, green, and

blue) after matrixing.

The only function of the oscillator and control circuits is to provide two signals to the demodulators, and the burst signal's only function is to synchronize the color oscillator with the station to assure proper color registration. Any defects in this section of a color receiver will cause one of two conditions: Either no color information will appear on the picture tube or the color information will not be synchronized with the black-and-white information. The face of the picture tube may then portray a stationary monochrome or black-and-white picture with color bars running diagonally. This is similar to the out-of-horizontal-sync condition often encountered in monochrome servicing. It will occur when the color oscillator is slightly off frequency, and the number of color bars running diagonally will vary according to the number of cycles the oscillator differs in frequency from the burst signal. The greater the difference in frequency, the greater the number of color bars. Coil L2 in Fig. 3 will have the greatest effect on the operating frequency of the color oscillator and this adjustment will be provided as a control at the rear of the receiver. If a condition of out-of-color-sync (color bars running diagonally) occurs, adjusting L2 will usually correct the condition.

In some instances the color oscillator may be so far out of sync that the number of color bars will be very high and they will not be distinguishable. Such a condition would generally be caused by a circuit defect. Whenever a condition of out-of-color-sync occurs you can be sure that the defect is in the color oscillator or control circuits. Of course any control that could cause this condition, such as tuning or coil L2, should be adjusted to correct the condition and then all the tubes in the suspected circuit should be substituted for.

If when tuned to a color telecast and only a black-and-white picture appears, the color oscillator and control circuits may be at fault. However, other circuits—such as the color killer and the burst amplifier, if defective—will cause the same condition.

Trouble-shooting in this section of a color receiver, once its function and operation are understood, should not be difficult. However, due to the critical phase and frequency tolerances, caution is necessary when component replacements are required. A number of resistors, capacitors, and coils have close tolerances, and exact part replacements should be obtained if at all possible. The general-purpose scopes of most service shops will be inadequate for checking this section because of the limited frequency response of the vertical amplifier. A scope with a vertical amplifier frequency response of at least 3.6 mc. will be needed to observe the color burst and oscillator signals.

(TO BE CONTINUED)

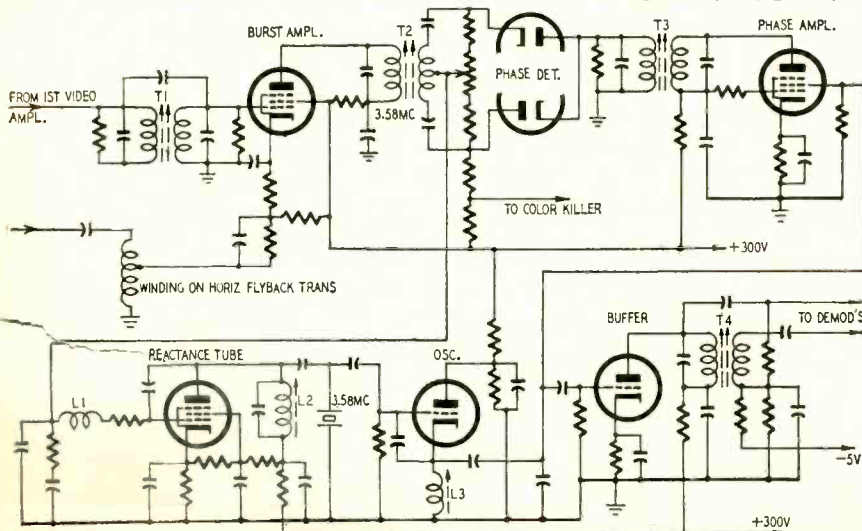

Fig. 3—These are the circuits that synchronize the color in the picture.

GHOST ATTENUATOR

By H. E. WARRINER

AFTER opening the TV door for maximum input from a good roof antenna installation, many of us have found that the excellent signal strength has included a bounty of dead cats. This is true particularly in city installations considered primary telecast zones—the dead cats being persistent ghosts from nearby tall buildings, chimneys, or gas tanks. This problem, encountered so close to the transmitters, calls for a compromise one way or another. You either live with double vision or seek out new antenna locations and set up separate narrow-beam antennas with matching stubs.

But what else can be done about persistent ghosts after you have done the best possible job of orienting your roof antenna in a strong multipath area? Before you compromise on one or two clear channels and discount the rest, here's how to put the principles of mismatch to work in a positive way: Attenuate the ghost!

For fringe-area reception the antenna lead-in should be perfectly matched to the TV set. Mismatch of the line will choke off reception as standing waves form on the line. Equalizing devices such as variable matching stubs will correct line mismatch for maximum fringe area reception.

In local strong-signal areas line mismatch creates standing waves that are amplified into visible ghosts by the great strength of the transmitted signal. The antenna may also produce ghosts from the crossfire of multipath reflections. The city dweller living close to transmitters receives too much signal power.

The handling of excess signal strength is recognized by many TV manufacturers who install *local* and *distance* switches in their equipment, or provide attenuation-pad instructions to accommodate their sensitive tuners. Too much signal input creates harmonics and too much contrast or loss of definition. So there is a definite need for control of the signal before it enters the TV set.

Since there are situations where multipath effect is almost unavoidable, lead-in mismatch and too much signal strength can further aggravate the problem. However, these factors can be harnessed to work just as well for good reception as against it. The 4-way antenna attenuator (Fig. 1) will give you a wide variable control of your TV antenna and lead-in. If you must accept a ghost-present compromise at the antenna you may still be able to fade the ghost before it reaches your screen.

Ghosts in a primary service area are subject to antenna and lead-in attenuation because there are two or more signals in the system, the original being the stronger. If the roof antenna is properly oriented toward the transmitters, any ghost-producing secondary signals will be entering the antenna pattern from the sides or rear. Their strength is therefore less than that of the primary signals. Because of this it is possible, by skillful attenuation and a degree of controlled mismatch, to minimize or completely eliminate such unwanted secondary signals. This can be done without sacrifice of a good picture from the original signal since it is over-abundant. There is a margin of decrease which is actually good, for the set is relieved of overload. This effect can be seen on clear channels where some attenuation improves picture quality.

Construction

The attenuator consists of four carbon potentiometers (taper unknown, probably linear) wired in a conventional attenuation network, mounted on a 4 x 4-inch lucite blank (Fig. 2). One 2-inch angle bracket holds the attenuator on the back of the set close to one side within easy reach for adjustment while you watch the picture screen. Lucite was selected for its low-loss characteristic at v.h.f., even though the attenuator was designed to insert losses into the line. The fact remains that there may be channels on which you will need maximum gain.

Experiments with and without line-matching stubs at the set terminals show that the line can be balanced to the set by proper adjustment of the attenuator so no additional line balancers are required. The device has also been used with excellent results from simple dipole, indoor antennas, giving improved reception in every case.

In the schematic, Fig. 3, two 5,000-ohm carbon potentiometers, A and B, are the main attenuators through which both legs of the line pass. Crossover 1,000-ohm balancing potentiometers C and D are equipped with regular line switches for cutting in and out of the circuit as needed. Some ghost conditions clear up best with either C or D in the circuit, or both. In my case, channel 2, New York City, which is perfectly clear without any attenuation, yields a better picture with some attenuation on A and B and a shade of crossover balance from D. Channel 4 requires the full system, while channel 7 needs only attenuation on B. The

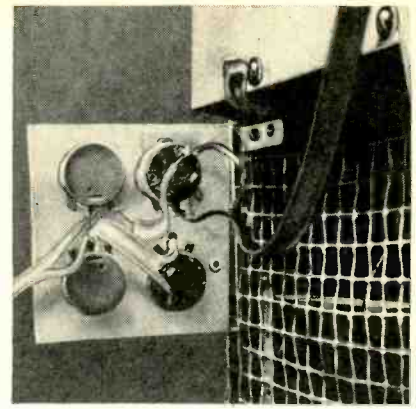

Fig. 1—4-way antenna attenuator.

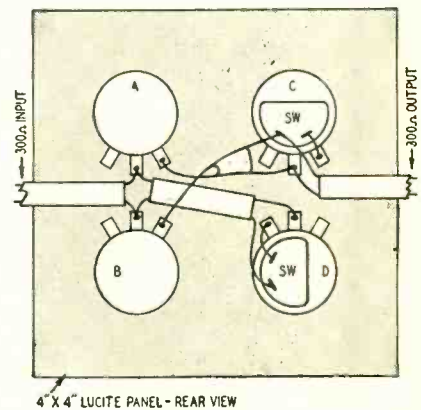

Fig. 2—Diagram shows the physical layout of the carbon potentiometers.

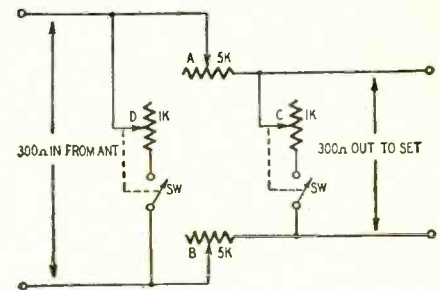

Fig. 3—Schematic of TV attenuator.

resistance values are high for purpose of strong ghost medicine on the low channels of the v.h.f. band.

Operation

The method of operation is simple and the only rule to follow is to watch your screen closely for the desired results—clear pictures. If your set has LOCAL and DISTANCE switching, turn to DISTANCE when using this attenuator; it will perform best at full input. With C and D cut out of the circuit, turn A and B away from zero until ghosts are eliminated or minimized. These controls work against each other as you are inserting degrees of mismatch into the lines. Then cut in C and D for line balance, checking all adjustments against each other for desirable shading. You will find that proper adjustment will reach a point of minimizing or routing the unwanted ghost. END

TELEVISION . . . it's a cinch

From the original "La Télévision? . . . Mais c'est très simple!" Translated from the French by Fred Shunaman. All North American rights reserved. No extract may be printed without the permission of RADIO-ELECTRONICS and the author.

By E. AISBERG

Twelfth conversation, first half: r.f. problems, visible noise, selectivity versus bandpass

WILL—Now that we've taken your "Empire State Tower" view of how a television receiver is made up, how about getting right down to circuits this time?

KEN—O.K.! Suppose today we follow the video signal from the antenna to the picture tube. We can forget the power supply, sync, and other auxiliary circuits for the time being.

WILL—In other words, we'll go through the r.f. amplifier, frequency changer, picture i.f., detector, and video-amplifier circuits. I didn't realize that TV was so much like radio—the only difference seems to be that instead of audio, we have video signals. All the rest is just the same!

KEN—You've been wrong plenty of times before, Will, but not often quite as dead wrong as you are now! How many times have I tried to tell you that even the best broadcast radio transmission has a bandwidth of less than 20 kilocycles, while a single television video channel is 4 megacycles wide? That one thing makes each and every circuit different!

WILL—Different, but not difficult. For instance, you wouldn't have to make your circuits as selective as in radio. You get out of one difficulty right there!

KEN—You mean you get into one! Just as in AM radio, you have to worry about trying to satisfy the opposite demands of selectivity and fidelity, so in television you are faced with the struggle between getting a broad enough band and getting enough gain.

WILL—You seem to have a few contradictions today yourself! Isn't it just the circuits that aren't selective that pass a wide band? When I remember how much trouble we used to have making our circuits selective enough, I don't think there can be much difficulty in cutting down the selectivity. All you have to do is use what in radio we called low-quality circuits.

KEN—This time you're right. Unfortunately, you can't get very much gain with "low-quality circuits." And you have to apply up to 50 video volts to the picture tube's control element, even though the signal on the antenna may be measured in microvolts. You need a voltage gain of several hundred thousand to do that!

WILL—So that's why a TV receiver has so many stages of different kinds of amplification?

KEN—That's the main reason. We'll go into some of the other reasons later.

Why the r.f. stage?

WILL—I've noticed that you can have a couple of r.f. stages, a number of i.f., and two or three video amplifier stages.

KEN—You don't see many sets like that! But sets with one r.f., three i.f., and one or two video stages are becoming the common type. And notice, Will, that when you have your i.f.'s tuned up above 40 mc, you are already in the v.h.f. range. So you can be studying v.h.f. while you learn how the i.f.'s operate.

WILL—But if that's so, why bother dividing up the amplification between r.f. and i.f. stages? Why not use just one 5-stage i.f. amplifier?

KEN—First of all, your amplifier is likely to oscillate if you cascade too many stages, even though the gain of each stage is pretty low. With two amplifiers working at different frequencies, you're going to have less regenerative

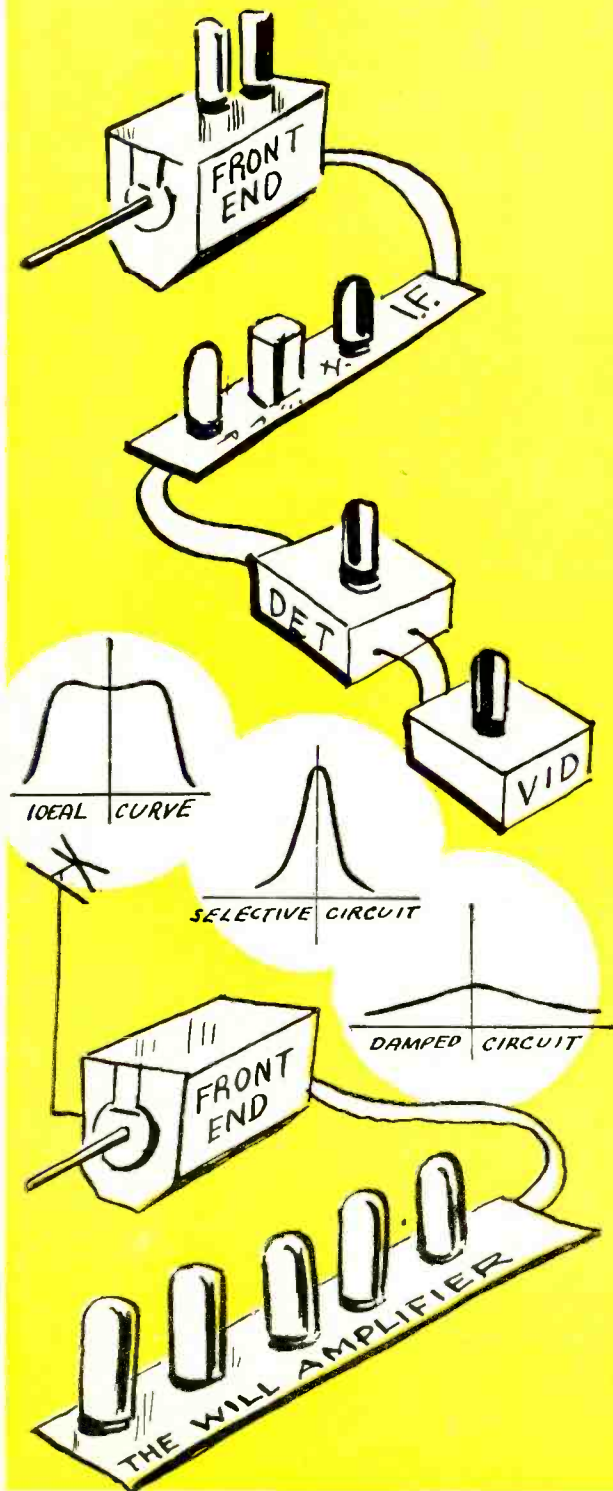

feedback. But the r.f. amplifier has a far more important advantage. You can use it to cut down the amount of noise as compared with signal.

WILL—But why worry about *noise* in a picture receiver?

KEN—The word “noise” came from AM radio, but we give it a little different meaning in television. It means all those current irregularities that result in the confused rushing noise you hear in an AM radio with no signal and the gain turned up. It’s caused by several things: the current flowing through resistors, oscillating circuit irregularities, and unevenness in the cathode emission of the many tubes in the set.

WILL—But even then, noise is inaudible in a video channel!

KEN—Yeah, but it’s not invisible! These irregularities of current—amplified through all the stages of a TV receiver—modulate the electron beam just as a video signal from a transmitter would. So the noise comes out on the screen as snow or a grainy image. I’m sure you’ve seen both, though maybe you didn’t know you were looking at noise!

WILL—So r.f. amplification makes the pictures less snowy?

KEN—Exactly! In more technical terms, r.f. amplification improves the signal-noise ratio. And it has still another advantage. Even though TV r.f. stages are not particularly selective, they are a great help in cutting down interference from stations on neighboring channels.

WILL—But I thought the FCC didn’t allot adjacent channels in the same area.

KEN—It’s supposed to work out that way, but there are places where there is adjacent-channel interference. And you have image frequencies to think about.

WILL—Oh, yes! If I remember right, they are frequencies that are the same distance away from your oscillator as are the frequencies you want to receive?

KEN—Queerly put, but I think you have the idea. But to make sure, suppose you have a channel 6 video signal at 83.25 mc. With the oscillator at 129 mc, you have an i.f. of 45.75. A signal at 174.75 mc will give you the same i.f. with the same 129 mc oscillator. The video carrier of channel 7 is at 175.25 mc, only a half megacycle away—well within the fine-tuning range of the usual receiver. Suppose you lived in a region where channel 7 was a strong station and channel 6 a weak one...?

WILL—... maybe I could get two programs at once, without buying the expensive special receiver I read about not long ago!

KEN—Except that you couldn’t unscramble them with polarized glasses! But seriously, I think you’ve learned enough to know how useful r.f. amplification can be in a TV receiver.

WILL—So let’s start with the r.f. stage. How about a diagram?

KEN—Here it is. You’ll recognize an old friend—the tuned-plate circuit—in this schematic.

WILL—Are you kidding? Don’t tell me that coil and resistor in the plate circuit are a tuned circuit!

KEN—Haven’t we talked about invisible components before? If not, we’d better start now—they keep getting more important as the frequency goes up! The capacitor you can’t see across the coil is really there! It’s made up of all the capacitances shunted across the winding—its own distributed capacitance, stray wiring capacitances, and the interelectrode capacitances (between the plate and the other electrodes of the first tube and the grid and other electrodes of the second tube).

WILL—But why not use a variable capacitor, like a real self-respecting tuned circuit...?

KEN—Because—to get any gain at all—we need as much inductance and as little capacitance as possible in our circuit. We even have to space the coil turns and keep leads as short as possible, to cut down distributed and wiring capacitances.

WILL—I suppose the first grid coil is also a tuned circuit?

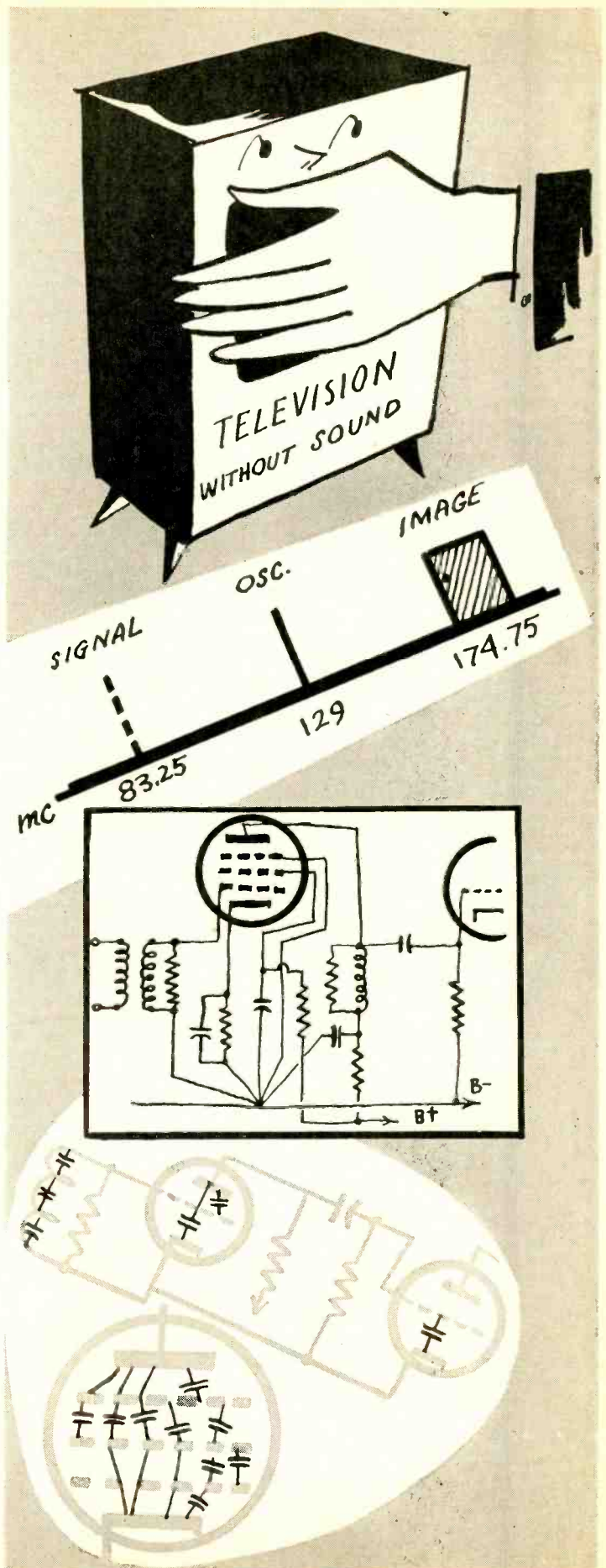

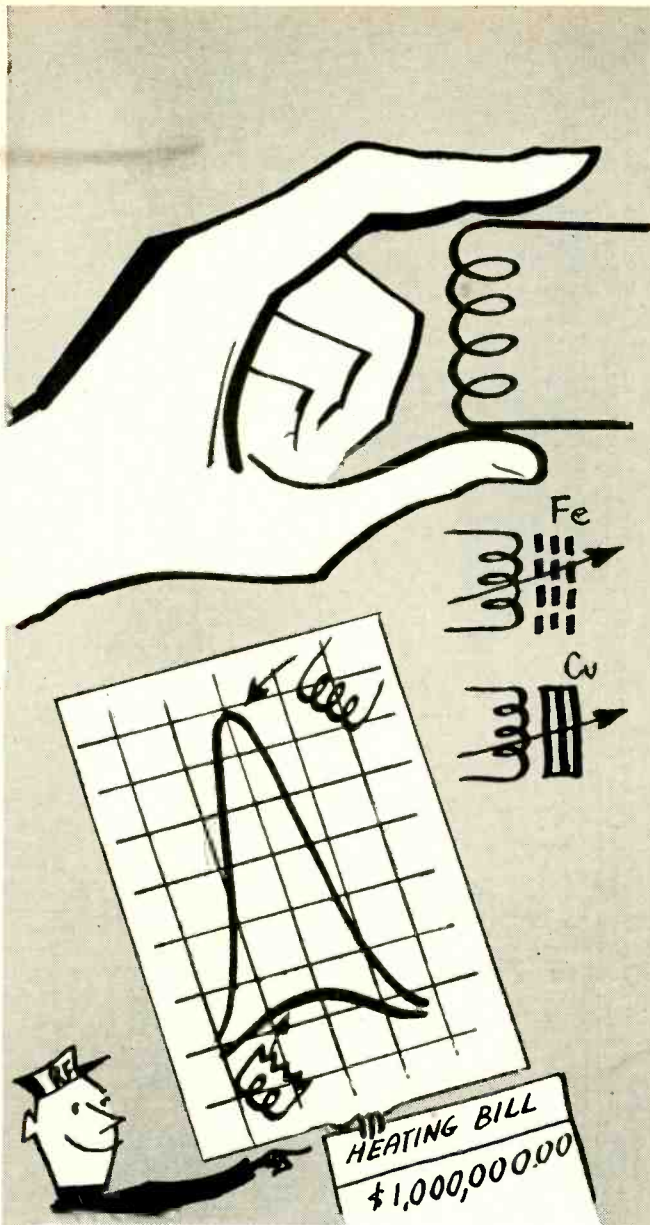

KEN—Yes. And you'll note that it's also inductively coupled to the antenna coil.

WILL—But I don't see any variable capacitors or cores if these are *tuned* circuits, how do you tune them?

KEN—By changing the coil inductance. Most of these coils are made of a few turns of fairly stiff wire, so you can tune them by squeezing the turns together or pulling them apart a little. But they use permeability-tuned coils occasionally at these frequencies, with cores of powdered iron or of copper.

WILL—I understand the magnetic core all right. But how can a nonmagnetic core change the inductance of a coil?

KEN—The r.f. fields set up eddy currents in the conducting core. And these currents set up fields that oppose and weaken the field of the coil. The effect is to reduce its apparent inductance. You'll notice that conductive cores have an opposite effect to that of magnetic ones, which increase the inductance.

WILL—Then I see a practical difficulty. How are you going to adjust the cores? If you move them in and out of the coil by turning a screw, isn't the metal in the screw going to get into the argument?

KEN—Quite correct. And that's the reason you'll often find the screws on this kind of coil made out of insulating material.

WILL—You see, I think of everything! But let's get back to our diagram. I see you have resistors shunted across your grid and plate coils. I hope they're high-resistance units! Otherwise they're going to absorb a lot of that high-frequency energy you've been trying to save.

KEN—I've bad news for you, Will! Their resistance is pretty low—may go down to 5,000 ohms or so. But you're quite right about their absorbing a lot of the energy in the circuits. That results in what the technicians call "damping." And it's just such damping or flattening of the selectivity curve that lets the circuit pass the necessary wide-frequency band.

WILL—That's not my idea of a smart operation. Just to pass all the video modulation frequencies, you feed the tiny parcels of energy you get from the antenna into these damped circuits. There you dissipate them in heat, instead of amplifying them to help the signal. Isn't that the most expensive form of heating in the world?

KEN—You're absolutely right, but we can't get away from it! Now you understand why stage gain is low. But, to make up for it, you can use very high-gain tubes. Some pentodes with extremely high gain have been developed specially for TV r.f. amplifiers. But, unfortunately, the more elements you get in a tube, the more noise it produces. So some manufacturers prefer to stick to the triode, with its lower gain and better signal-noise ratio. Now practically all TV front ends have an r.f. amplifier that uses the famous *cascode* circuit, which consists of two triodes so hooked up that they give the gain of a pentode with the much lower noise level of two triodes.

(TO BE CONTINUED)

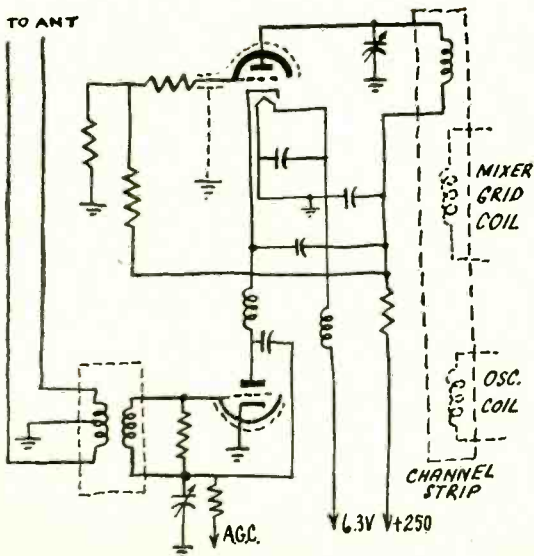

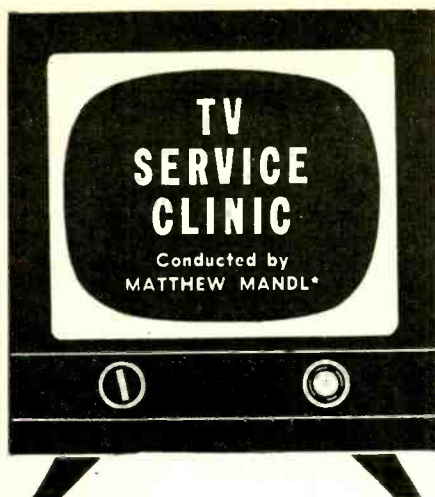

MENTION mathematics to some service technicians and you get either a cold stare or an effort on their part to change the subject—but quick! Perhaps my mention of math in this opening paragraph has the same effect on you and you're thinking: "If he's going to discuss *that* this month, I might as well skip reading the Clinic this time."

I hope you keep reading, however, because simple math can help you with many servicing problems. I'd like to illustrate:

Example 1. Sometimes you suspect that the second-anode current of a picture tube is excessive. It's easy enough to measure the current—but what amount is excessive? The general rule given by tube manufacturers is that the second-anode voltage multiplied by the average anode current should not exceed 6 watts. Thus, suppose you measure 12,000 volts on a 16GP4 tube—what is the current limit? Since current flow is equal to power divided by voltage, we divide 6 by 12,000 and get 0.0005 ampere, or 0.5 milliamperere. Thus, ½ milliamperere of current is our limit for the 16GP4 with 12,000 volts at the second anode.

Example 2. There are 20 horizontal dark bars on the screen of a picture tube during reception. What is the frequency of the interfering signal? Since the screen is darkened 20 times during the vertical scan which occurs in 1/60 of a second, the frequency of the interfering signal is 60 times 20, or 1,200 cycles. (One or two bars may not be visible because of retrace, but the calculation will give a fairly good idea of the approximate frequency of the interfering signal.)

For vertical bar interference, multiply the number of visible bars by 15,750 to calculate for the frequency of the interfering signal *which is reaching the picture tube.*

If the interfering signal is arriving at the antenna and is not generated within the set itself, the above calculation indicates the *difference* frequency

*Author: Mandl's Television Servicing



Fig. 1—Mis-adjusted focus assembly.

Fig. 2—Video amplifier overpeaking.

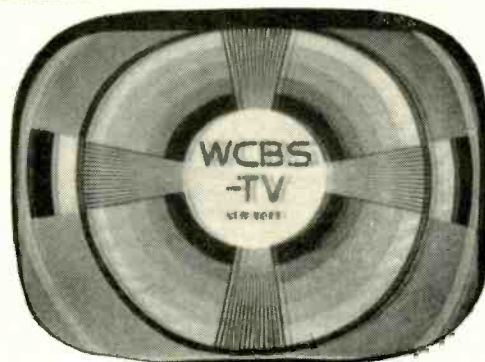

which results when the interfering signal mixes with the local oscillator signal in the tuner.

Example 3. Your customer wants a 12-inch speaker mounted in his console television. The set now has a 6-inch speaker, but you don't know its impedance. The schematic indicates that a single 6V6 audio output tube is used. The tube manual recommends an 8,500-ohm load resistance. You disconnect the voice coil from the output transformer, and remove the 6V6 tube. You now put 1 volt a.c. on the secondary of the audio output transformer and read the primary voltage. (Assume the primary voltage now reads 46 volts a.c.) This indicates the turns ratio of the transformer, 46 to 1. Now square 46: $46 \times 46 = 2,116$. Divide the recommended load resistance by 2,116: 8,500 divided by 2,116 equals 4 (approximately). You then get a new speaker having a 4-ohm voice coil.

The foregoing samples require simple mathematics. If you become more proficient as well as familiar with the many formulas which can be used, you will find it saves considerable time.

NOTE: I regret to inform the readers of the Service Clinic that the press of other work forces me to withdraw from editing this column. The Clinic will continue, however, so keep sending in any queries you have on television servicing. I'll still be associated with this magazine as television consultant and as a contributor of articles from time to time.

Inverted picture

After replacing the vertical output transformer in a Philco model 2272 receiver the picture was upside-down. I'm sure I wired the secondary to the

yoke properly, but I had to reverse the leads to get the picture right-side up. Is there some condition which I've missed with respect to the picture inverting? What other conditions cause an upside-down picture? J. V., Bethpage, L. I.

The color code of the secondary may have been incorrectly indicated. Since the picture is now all right, it is obvious that reversed leads caused the trouble. The only other condition which gives an inverted picture is extreme fold-over. During the latter condition the picture overlaps and the secondary image will be inverted.

Bottom margin

I have been attempting to correct a black margin at the bottom of the picture tube in a Stromberg-Carlson model 317. I suspect the circuit associated with the 6BL7-GT tube is creating this condition. Is there some circuit change which I could make to correct this condition? O. J. B., Olean, N. Y.

When this condition appears, circuits should not be changed, but rather the faulty tube or component causing this trouble should be located. A black margin at the bottom may be caused by improper picture positioning. For this reason the focus assembly should be adjusted to center the picture properly, and the height control should be adjusted to fill out the mask. A mis-adjusted focus assembly can cause considerable picture shift, as shown in Fig. 1. If height is inadequate, the vertical output tube should be replaced. If this does not help, a check should be made of the resistors and capacitors as well as other components in the vertical oscillator and output amplifier.

TELEVISION

The vertical linearity control may have to be readjusted when the height is changed, since these controls often affect each other.

27NP4 substitution

I would like to change the 27NP4 picture tube in a Muntz chassis 17B8 to some other 27-inch picture tube. What tube will produce the most brilliancy and contrast and be mechanically interchangeable with the 27NP4? E. C. P., Park Forest, Ill.

You could use the 27RP4 tube which has an aluminized face. This will give you better brilliancy and contrast, and this tube is interchangeable with the 27NP4. With the 27RP4, however, you may get a brilliancy decrease if the high-voltage system of the receiver is not operating at peak efficiency. Usually the 27RP4 is operated at approximately 1,000 volts more on the second anode than the 27NP4 for the brilliancy necessary for daylight viewing. The 27RP4 is 1/16 inch longer than the original tube. You could also use a 27LP4, except that this tube is 1 23/64 inches longer than the 27NP4. The 27LP4 requires approximately 2,000 volts more than the 27NP4.

Color conversion

One of our local television stations is broadcasting some programs in color. I am interested in receiving these in color, and have been wondering whether or not it would be practical to convert a present black-and-white set to color. If it is practical, I would appreciate advice on what problems are involved. W. E. M., Charlotte, N. C.

It is not practical to convert a present black-and-white receiver to color, since the cost would be almost that of a new color receiver. For color reception it is essential that the video i.f. stages and the turner have a bandpass of 4.2 megacycles to receive full color information. Many existing black-and-white receivers have an i.f. bandpass of only approximately 3.5 to 3.8 mc. and would thus be unable to properly handle the color information. In addition, it is necessary to have color demodulator circuits, a subcarrier oscillator, bandpass amplifiers, matrix systems, and a much higher second-anode voltage. These factors, plus numerous other circuit modifications, make the project impractical at the present state of the art.

Sync troubles

I have just completed wiring a 630 type television kit. The picture quality is excellent but I receive a picture where both the vertical and horizontal blanking bars meet at the center of the screen. By decreasing the vertical oscillator grid leak the picture moved up into its correct position vertically. By decreasing the 27,000-ohm horizontal oscillator grid leak, the other blanking bar disappeared to the right. I can hold the picture in the center of

the screen now, but the horizontal and vertical hold controls no longer lock in at the center of their range and they are critical. The horizontal and vertical controls are at the extreme end of the range and the core of the synchrolock discriminator secondary is screwed all the way in to keep the blanking bar at the right of the screen. Could you tell me how to correct these defects? P. C., Toronto, Ontario.

Off-value parts in the vertical and horizontal oscillators would necessitate setting the controls at the extreme end of the range for proper synchronization. This can be corrected by checking all parts values against the schematic and replacing any which are off by more than 5%. If this does not help, the lack of center-range control may be caused by improper lead dress. Wires should be kept short and spaced from other component parts or adjacent wiring. If this does not help, the series resistors in the hold-control circuits can be changed to permit center setting. When the vertical circuit is out of synchronization it should roll and not lock in with the blanking bar across the center. When the latter occurs, it usually indicates a higher than normal hum level. When a 60-cycle hum enters the vertical circuits, the hum signal can cause a lock-in, and, depending on the phase of the 60-cycle signal with respect to the sync, the blanking bar may be visible across the screen.

Incorrect voltages in the horizontal oscillator also will cause unstable synchronization. Most technicians are not aware that the synchro-lock horizontal a.f.c. system used in the 630 receiver requires a step-by-step adjustment for good lock-in as well as pull-in. This involves adjustment of the phasing control and the frequency control, as well as the hold control. If this information was not furnished with the kit, you can find it in the original RCA 630 service notes.

Overpeaking

In several receivers I have serviced lately I noticed a picture which either has a very slight ghost effect along the right-hand side of the objects or a slight highlight along such edges. The fine-tuning will, in some instances, partially eliminate some of this trouble, but usually not completely. I understand the cause for the ghost reception, but would like your explanation regarding the cause for the faint highlights or repeat lines following objects in the picture. C. C. M., Seardsdale, N. Y.

Such repeat lines may be caused by overpeaking in the video amplifiers (see Fig. 2) or by a misoriented antenna. For this reason, check the antenna orientation, and if this does not help, you will have to check the tubes and parts in the video-amplifier stages. Incorrect values in the peaking coils, or shorted turns in the latter will affect fine detail. When the peaking

coils do not have the right value they may over-accentuate the high-frequency response, which will result in trailing edges at fine-detail picture information. Voltage checks also should be made, since abnormal voltages can aggravate the high peaking condition. The most simple testing procedures consist of checking tubes. If these do not help, voltages and part values should be tested, using accurate equipment.

Weak volume

I am servicing an RCA model 7T103B chassis KCS47F. The complaint is low sound output, although the picture is O.K. This is a split-carrier type, taking the sound i.f. from the 3rd video i.f. stage through a sound take-off coil. The sound is not distorted and it is not extremely weak, except that the volume control must be turned up all the way for normal listening. All of the tubes in the sound i.f. stage and audio have been replaced and the i.f. coil feeding the limiter has been taken apart and examined and found to be O.K. I can short out the limiter screen resistor and raise the sound output almost 3 times, but the fine-tuning control must be readjusted to get the increased sound, and then the picture detail suffers. All capacitors and resistors check, so I am at a loss to understand the low audio output, unless it could be caused by a defective sound take-off coil or discriminator coil. When adjusting the discriminator to zero at 21 mc it seems that the dip from positive to negative is not as sharp as it should be, as I must keep turning the adjusting screw several turns before it starts in the other direction. Any help you can offer me in correcting the above trouble will be very much appreciated.

Since the picture is all right, the weak sound undoubtedly is caused by troubles after the sound take-off. You mentioned having checked all the tubes as well as replacing the i.f. coil feeding the limiter. Since you have also checked capacitors and resistors, the trouble is probably caused by incorrect sound i.f. alignment. For this reason you should check the sound i.f. and discriminator alignment, using accurate equipment and referring to the step-by-step procedures given in the service notes for this receiver.

If you have adjusted the controls without accurate generators, you may have thrown them off to a point where the cumulative effects are contributing to a decline in output. If proper alignment fails to give good results, and if you are sure that tubes and components are all right, you may have to replace the sound take-off coil as well as the discriminator inductance. Before doing this, however, check the output transformer to make sure no shorted turns or other defects exist. When difficulty is encountered in adjusting the discriminator circuit, it is usually caused by an unbalance. END

REJECTION FILTER FOR TV BUZZ

Sync buzz, 60-cycle hum, and other audio interference can be eliminated with a notch type filter like the parallel-T

By IRVING GOTTLIEB

MANY intercarrier TV receivers produce an annoying 60-cycle buzz or hum despite correct adjustment and compliance with the manufacturer's operating instructions. This is caused because the audio amplifier responds to the 60-cycle field repetition rate. Ideal design would eliminate this undesired signal ahead of the audio channel. This is hard to do in practice. However, it can be trapped out of the audio amplifier by substituting for the conventional R-C

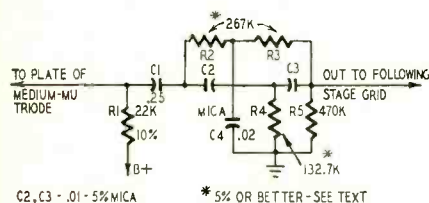

Fig. 1—The parallel-T filter network.

coupling elements a special parallel-T filter network. The technique is also suitable for audio amplifiers in other applications which are plagued with 60-cycle interference from the power lines.

The 60-cycle interstage coupling filter is shown in Fig. 1. Many combinations of resistance and capacitance attenuate 60 cycles. Only a few of these are satisfactory for use with vacuum tubes. The values shown were found to provide the best compromise between insertion loss, good audio frequency response, and effective 60-cycle rejection. The parallel-T coupling network reduces the gain to about 85% of that obtained with the conventional R-C coupling network it replaces. This figure was obtained experimentally by measurements at 1,000 cycles. In other words, the insertion loss is about 1.5 db. In TV receivers, this can generally be tolerated, and is a worthwhile exchange for annoying 60-cycle buzz.

Fig. 2 shows the frequency response of a test audio amplifier incorporating the parallel-T coupling network. The degree of network balance affects the response. Good balance increases the attenuation of 60 cycles and improves

the over-all audio frequency response as well. The high-frequency response is very good—better, in fact, than that from the conventional R-C coupling circuit. The combined effects of grid input capacitance and stray wiring capacitance do not degrade the response at high frequencies as rapidly as the ordinary R-C coupling network.

For good balance the parallel-T components (C2, C3, C4, R2, R3, and R4) should all have tolerances of 5% or better. Values specified in Fig. 1 give best results when working from the plate circuit of a medium- μ triode. Other types increase the insertion losses. R2 and R3 are each made by connecting 240,000- and 27,000-ohm 5% resistors in series. R4 is made by putting 2,700- and 130,000-ohm 5% units in series. R1 and R5 need not be precise values. Optimum performance in any given circuit is obtained by substituting variable components for C4 and R4 and

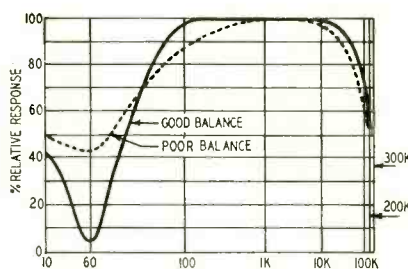

Fig. 2—Sharpness rejection notch varies with values of the components.

adjusting these for exact circuit balance. A 250,000-ohm potentiometer may be used for R4. Replace C4 with a .015- μ f capacitor. Connect .001 μ f capacitors in parallel with C4 to bring the effective capacitance up to the vicinity of the nominal .02 μ f. For each change in one arm, the other should be readjusted. This tuning procedure is easy with the test circuit of Fig. 3. Although the performance of the bridge is greatly improved by precise adjustment of all its elements, tuning the shunt arms alone will produce a 60-cycle voltage rejection ratio of somewhere between 80 and 150 to 1. This

is more than enough to trap out 60-cycle interference and yield good audio frequency response in television receiver and amplifier applications in general. If an extremely sharp rejection characteristic is required, vernier adjustments of the series elements will be needed. The actual calculated value of R2 and R3 is 265,770 ohms; that of R4 is 132,885 ohms. These values were derived in terms of the 0.01- μ f and the 0.02- μ f capacitors used in the other bridge arms. The equation for balance or resonance is $C4 \times R2 = 4 \times C2 \times R4$ when using the configuration in Fig. 1 where $R2 = R3 = 2R4$ and $C2 = C3 = \frac{1}{2}C4$. The resonant frequency in cycles equals $0.159/C4 \times R4$, where C is in microfarads and R is in megohms.

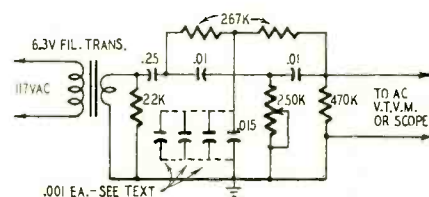

Fig. 3—Setup for tuning the network.

Parallel-T filters such as this have numerous other applications in audio, electronic control, and communications. A filter tuned to 10 kc may be inserted in the audio-amplifier circuits of a high-fidelity tuner or receiver to attenuate adjacent-channel heterodynes and whistles. Tunable filters may be used in communications receivers to eliminate heterodynes and interference. Tuned amplifiers for communications and electronic control often use a parallel-T network in a feedback loop. The feedback voltage is lowest and the amplifier gain is maximum at the resonant frequency. All other signals are attenuated in proportion to the feedback voltage at that frequency.

The parallel-T is the ideal frequency-selective network for miniaturization of circuits in audio oscillators, tuned amplifiers, and filters in electronic control applications such as radio control of model boats and airplanes. END

HIGH - QUALITY AUDIO

Part XII—A popular “inverter,”

the cross-coupled amplifier

By RICHARD H. DORF*

THE final type of phase splitter we shall discuss here is more complex than the previous ones. It is known as the *cross-coupled* circuit and was designed to overcome the one characteristic disadvantage of all the more common types.

Almost every common phase splitter is unbalanced at the high and low fre-

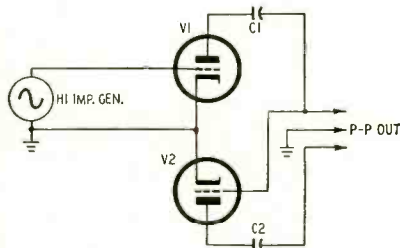

Fig. 1—Conventional phase splitter.

quencies because of two factors: First, the inverted signal goes through two vacuum-tube amplifiers, while the uninverted signal presented to the other output-tube grid goes through only one. Thus the inverted signal is twice subjected to the effects of tube output capacitance and Miller effect, with the result that its treble output is lower than that of the uninverted signal. Second, the inverted signal goes through d.c. blocking capacitors twice, so that its low-frequency output is somewhat poorer. And of course at both ends of the spectrum the phase of the two signals is not exactly opposite because of the unequal phase-shifting effects of the unequal capacitive reactances.

It is true that in a well-designed conventional circuit this characteristic unbalance can be reduced to a very low degree by a good choice of com-

*Audio Consultant, New York City

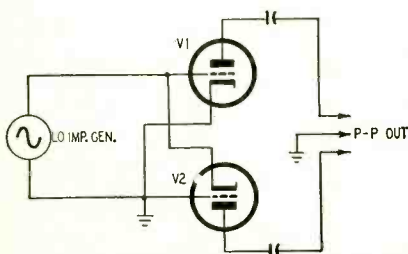

Fig. 2—A balanced phase splitter.

ponent values, and most amplifier designers do not go to the trouble and expense of using the cross-coupled circuit. However, some amplifiers do contain it, and it does maintain balance over a larger spectrum, with resulting possibility of more negative feedback and less danger of instability.

The cross-coupled circuit really does only one thing. It makes sure that both the inverted and uninverted signals are subjected to the same (or very nearly the same) reactive effects.

Figs. 1 and 2 make this clear. Fig. 1 is a simplified a.c. diagram of a conventional phase splitter. A generator (phonograph preamplifier, or a voltage-amplifier stage) feeds the grid of V1. The output of V1 goes through C1 to the upper output lead. So far so good. Some of the signal from the upper output lead (voltage divider not shown) is fed to the grid of V2, and the V2 output goes through C2 to the lower output lead. Notice that the upper output signal has gone through one tube and one capacitor; the lower signal has gone through two of each. Obviously, there is no balance.

The split-load inversion circuit has the same defect because, as we explained last month, the plate output is at a high impedance, allowing tube output capacitance to have its effect, while the cathode output capacitance is swamped by a low output impedance.

Fig. 2 shows the ideal balanced splitter (again as a simplified a.c. diagram). The identical signal is applied to both tubes, but in phase opposition. Each signal goes through only one tube, and if the tubes are identical the outputs must be balanced. There is, of course, one additional requirement. The lower tube V2 is operating as a grounded-grid amplifier with cathode input, so its input impedance is low. The source of signal, shown as a generator, must therefore also be of low impedance. And the low generator impedance swamps out the input capacitances which exist across the grid circuit of V1.

If we tried to replace the generator symbol of Fig. 2 with a practical source such as a preamplifier output and, without using transformers, tried to fill in the details and make Fig. 2 practical, we would have quite a problem in completing the d.c. circuits for plate cur-

rent and bias. For that reason it is necessary to use two additional triodes as shown in the complete circuit of Fig. 3. (Actually two duo-triode tubes are used.)

Cross-coupled amplifier

The 6SL7-GT V3-V4 performs in the same way as V1 and V2 in Fig. 2. The 6SN7-GT V1 and V2 of Fig. 3 simply provides the low-impedance source and facilitates the d.c. connections. V1 and V2 do no phase inverting in themselves.

The sequence of events is not hard to understand. The single-ended input signal is placed between V1 grid and ground, across R1. V1 is a cathode follower and its output appears between its cathode and ground—that is, across R2 and the upper part of R3.

A cathode-follower output signal would normally be applied to the grid of the following tube. However, remembering what we said in connection with Fig. 2, the signal is fed to the cathode rather than the grid of V3.

Let us assume for a moment that R4 does not exist and that the V3 and V1 cathodes are connected together. We know that a signal fed into a tube must be effectively placed between grid and cathode (remembering that it is usually “grid-and-ground” simply because the cathode is usually grounded). But the grid of V3 is not connected to any signal point where, as far as we can see, this condition is fulfilled.

The answer to this is simple. The V1 and V2 circuits are symmetrical for

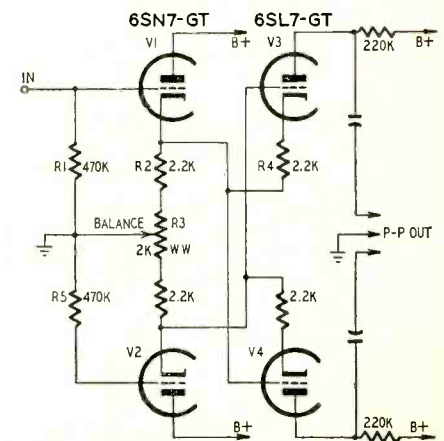
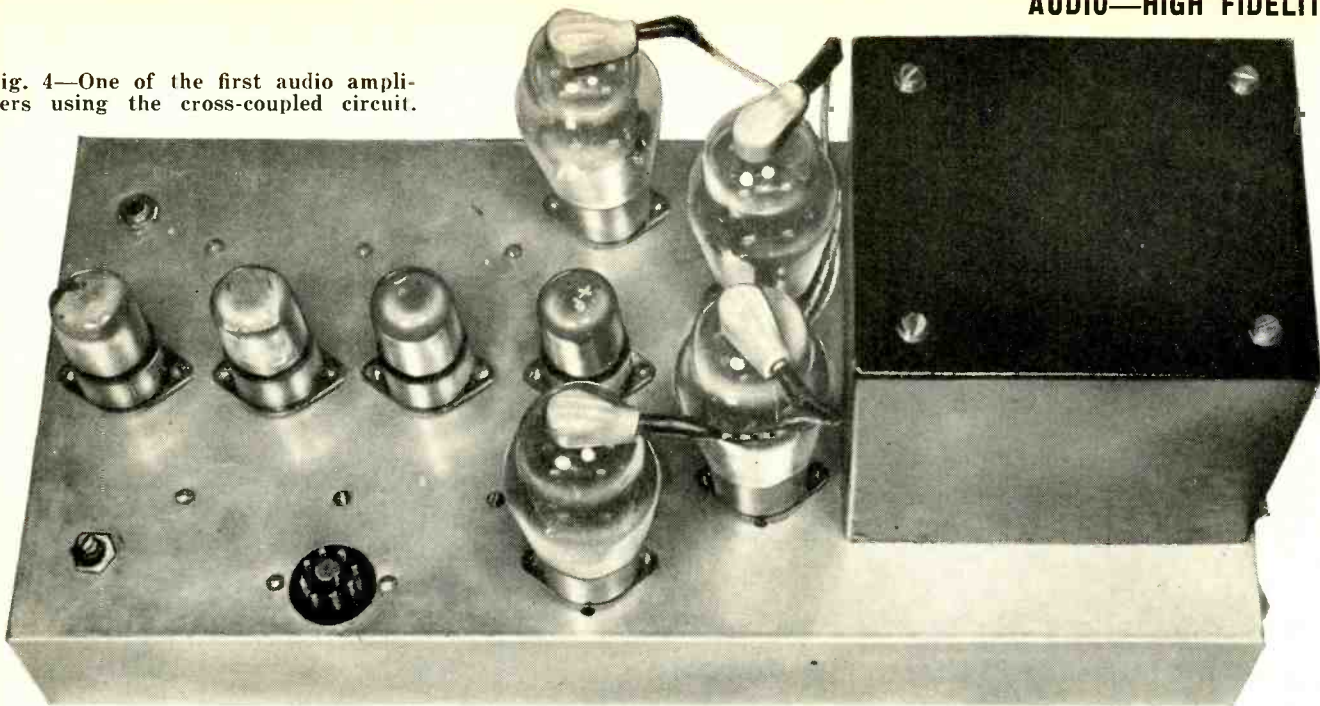

Fig. 3—The cross-coupled amplifier.

Fig. 4—One of the first audio amplifiers using the cross-coupled circuit.



d.c., and, because of the cathode resistors, both cathodes are positive with respect to ground. For a.c. the cathode of V2 corresponds to ground; so that connecting the V3 grid to that point is the same as connecting it to ground, as far as the signal is concerned. With the V3 cathode at the same potential as V1 cathode and the V3 grid at ground, the a.c. signal excites V3 and an audio signal is produced at its plate.

The d.c. potentials at the cathode and grid of V3 (with R4 shorted) are identical, so that V3 is operating with zero bias. To get the correct bias we insert R4. Current passes through R4, making the V3 cathode more positive than the V1 cathode and the V3 grid—and there is the bias. (But even though a d.c. voltage drop across R4 creates bias, there is no audio voltage drop across R4 which would reduce the transfer of signal from V1 to V3. This is simply because we apply only a potential to a tube input to excite it and the tube input draws no current).

Now let us see how V4 operates. The V4 grid is connected to the V1 cathode, while the V4 cathode is connected to the V2 cathode. This is exactly the opposite to the V3 connections. The V2 cathode serves merely as a point of equal potential and handles no signal.

It should be obvious now that the V3-V4 circuit of Fig. 3 is a practical design of Fig. 2, and obvious why *cross-coupled* is a good term to apply. The low-impedance generator required in Fig. 2 is the cathode-follower V1 of Fig. 3. V2 does no work of the kind usually expected of a tube; it simply provides a necessary d.c. level. The balance potentiometer R3 compensates for any variation in tubes or components and allows the d.c. level at the V2 cathode to be set so that it is exactly the same as that at the V1 cathode.

However, there are three very useful ways in which V2 can be put to more profitable use. Notice that the entire circuit from beginning to end is perfectly symmetrical. Obviously the input can be applied to either V1 or V2 with equivalent results except that the phase at the push-pull output will change. The circuit thus can be used as a push-pull amplifier for balanced signals. A typical use might be as a transformerless bridge to monitor a balanced broadcast or telephone line.

Two separate single-ended signals also may be applied to the two grids, in which case the circuit is a combination electronic mixer and phase splitter. For this use R1 and R5 might be made potentiometers, with the grids connected to the arms.

The third use, which is desirable wherever the circuit is used, is as a self-balancer so that no instruments need be used to set R3 properly. If a single-ended signal will change phase at the output when changed over from one grid to the other, then the same single-ended signal applied to both grids in parallel will produce cancellation and zero output—if the circuit is properly balanced. Therefore, to set the balance control, any single-ended signal is applied between ground and both grids temporarily connected together (perhaps by a push-button). Then R3 is varied until no output is heard, and balance is perfect.

The circuit as shown in Fig. 3, once the balance adjustment is set, can be unbalanced only by a difference in the output capacitances of V3 and V4. This is only a fraction of a μf and unbalance is negligible up to almost 1 mc. The voltage gain of the circuit is 25, and the output can be run up to 50 volts or more (meaning input maximum of 2 volts or so) without significant distortion. Negative feedback from the output transformer can be fed to the

V1 cathode. It need not be fed symmetrically to the V2 cathode as well, because a signal fed only to the V1 cathode will give balanced results for the same reason that the V1 signal itself does. The feedback could be connected to V2 instead, of course, with the same results.

Fig. 4 shows one of the first amplifiers made available to high-quality audio enthusiasts using the cross-coupled circuit. It was designed by Ulric J. Childs. The first two tubes at left are for the cross-coupled circuit. The next is a gainless feedback stage, and the fourth is a direct-coupled driver for the push-pull-parallel 807 power stage.

Power output stages

The power output stage of an amplifier might well be characterized as the most important because it is the hardest stage to design and operate correctly. The output stage, unlike those preceding it, is concerned with power, a good deal of power which must drive a loudspeaker required to push a considerable amount of air—a substance not as light as some might think. Designing a good power stage is a little like training an elephant to dance the more delicate selections from Tchaikovsky's *Swan Lake* ballet. Just as in mechanical engineering bodies are harder to move accurately and quickly when they are larger and heavier and require more pushing power, so power output stages are harder to control accurately than voltage amplifiers which merely deal with voltages and do little if any actual work.

The reasons for the difficulties and the methods used to clear them up are more intricate than in mechanical engineering and brute force is of little value. Next month we shall embark on our discussion of the power amplifier.

(TO BE CONTINUED)

servicing

HIGH-FIDELITY

equipment

Part VI—Using oscilloscope patterns for analyzing and locating troubles

By JOSEPH MARSHALL

THE testing routine using the IM analyzer with or without a scope as detailed in my last article, is by far the most effective when the IM is below 10 or 12%. But when the IM distortion is higher, amplitude distortion usually exceeds 3%, and in that case using an audio generator and a scope to give a phase-shift pattern is faster and yields more information. This method has been described many times, but seldom from the point of view of the service technician—that is, with the purpose of pointing out how it may be used most effectively to diagnose trouble.

The layout for this type of testing is shown in Fig. 1. The amplifier is loaded by the internal load of a wattmeter, or, if no wattmeter is available,

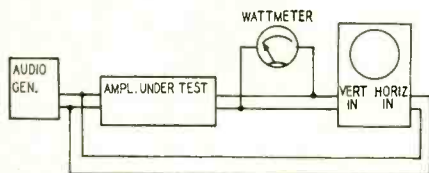

Fig. 1—Audio amplifier test setup.

by an appropriate load resistance. The wattmeter is most helpful as an indicator of the output level at which distortion begins.

The IM analyzer should be handy for making IM runs, since it is still the best measure of real high-fidelity performance. All that is necessary to make an IM run is to substitute the signal from the IM analyzer for that coming from the audio generator, and to shift amplifier output from scope to the analyzer portion of the IM meter. The shop specializing in hi-fi servicing might very well construct a junction

and switch box (Fig. 2). Thus the instruments could be connected to the junction box more or less permanently. All that would be necessary to make a test would be to run three wires from the amplifier under test—a common ground, a hot input and a hot output. The double-throw switch would automatically change the setup from scope to IM analysis.

The test procedure is simple, once it has been tried a few times. We will assume your scope has a square on the ruled grid, of the type shown in various diagrams of Fig. 3. If it does not, you can ink one on or make a new one of thin plastic to slip over the present one. Such a marking is of very great assistance in interpreting the patterns and diagnosing causes of changes in it.

Phase-shift patterns

Set the audio generator for around 1,000 cycles. Adjust the generator output, the amplifier gain, the scope gain and positioning until you obtain a straight line running diagonally from corner to corner of the square, as in *a* of Fig. 3. If you do not get a straight line, but rather some sort of oval or ellipse, shift the generator frequency until you find a point at which a line is formed. It will take some experimenting to learn how the various controls are manipulated to obtain this diagonal line. It will help if you remember that increasing the vertical amplitude or gain of the scope or the volume control of the amplifier will tilt the line upward, while increasing horizontal gain will tilt it downward. Concentrate at first on obtaining a line of any length, which tilts the necessary 45°. When you have this, position it in the center of the square. Now an increase or decrease of generator out-

put will either stretch the line or contract it so that it goes from corner to corner of the square without changing the tilt.

The straight line, running from corner to corner of the square, indicates that the voltage applied to the horizontal plates of the scope is exactly equal to that applied to the vertical plates; and that there is no (or 180°) phase shift between generator output and amplifier output. Any change in the output of the generator, the gain of the amplifier, and any shift in phase, will be indicated by a change in the pattern. Changes in output or gain will change the *size* of the pattern; changes in phase will change the form or shape and possibly the size too. What's more you can tell at a glance whether the change is due to a change in generator, amplifier, or both.

For example, let us suppose the amplifier is flat but the generator is not. If generator output increases or decreases, the pattern will enlarge or contract in *both* directions. If generator output increases, the straight line will expand beyond the square; if lowered, it will contract inside the square. If instead of a line, there is an ellipse or circle, these too will either expand beyond the square or contract within it. Ordinarily a change in generator output will not produce a change in the form of the pattern, but the inclination or angle of the line or pattern may change. These changes are detailed in *a* of Fig. 3.

If the generator output is constant, but amplifier gain varies, the pattern may shift in form because of phase shift, and will enlarge or contract in the *vertical* direction. *As long as the generator output is constant, the extremes of the pattern will continue to*

touch the sides of the square; but, if amplifier gain varies, they will no longer touch the top and bottom. These effects are shown in *b*. You may have both a shift in size and a shift in form. If amplifier gain is constant, but there is a phase shift within it, the size of the pattern will be the same, but the line will turn into an ellipse or vice versa. On the other hand, you may have both a change in phase and a change in gain; in that case the form will change and the pattern will enlarge or contract vertically. The important thing here is to keep in mind that whatever the change in the pattern, if it continues to contact the two sides the change is due entirely to a shift in amplifier characteristics.

There may be a combination of effects—the generator output may change and the amplifier gain may simultaneously increase or decrease. The change in the trace will depend on the net effect and can be analyzed by examining the relation of the trace to the sides of the square. Thus if the generator output decreases but amplifier gain increases to a greater extent, the pattern will no longer touch the sides of the square, and will pass through the top and bottom; conversely, if generator gain increases, but amplifier gain falls off to a lesser extent, the pattern will pass through the sides of the square but will no longer touch top and bottom.

In other words, the pattern reflects the changes in both the generator and the amplifier under test and you can tell at a glance whether the change is due to generator or amplifier or both. There is no necessity for monitoring the output of the generator or the amplifier; the scope simultaneously monitors both of them. Drawings at *c* in Fig. 3 show effects of changes in generator output and amplifier gain.

Distortion indications

All the forms of distortion which occur in amplifiers are indicated on the phase-angle patterns. For instance, clipping due to underbiasing or overdriving will be indicated by a very sharp bend of the line toward the outside of the square and an extension of the line parallel to the top or bottom as the overdriving becomes more severe. If you will recall what I have already said about the behavior of this setup, you can understand this readily. Clipping means that the amplifier is saturated—its gain stops and a further input of signal produces no further increase in output. So the signal delivered to the vertical plates of the scope does not increase. On the other hand (assuming that we control gain and produce the distortion by increasing generator output) the input to the vertical plates continues to increase. So the line pattern stops growing upward, but continues to grow sideward. Because the relation between the two forces has changed, the angle of the line at its end changes, therefore the

sudden bend in the line pattern.

At any rate, clipping due to either overdriving or underbias produces a very severe and sharp bend as indicated in *a* of Fig. 4. If the clipping occurs only on the positive or the negative peak, the bend will show on one end of the line only. If it occurs on both positive and negative peaks, you have a similar bend on both ends. A single bend may result from overdriving a single-ended amplifier such as a pre-amp; or it might be the result of overdriving one side of an unbalanced push-pull stage. Symmetrical bending occurs only in push-pull stages; if the two bends appear at about the same signal input level, the stage is well balanced; but if one bend appears long before the other, the stage is unbalanced.

If the pattern is ellipsoid or circular, the top of the trace will be squared to a straight line and a crimp will appear in the rounded portion close to one end and on the outside of the pattern. In symmetrical clipping, the effect occurs on both ends.

How do you tell whether the distortion is due to overdriving or underbiasing? Very easily. In a well-designed amplifier, such as any commercial high-fidelity amplifier, overdriving occurs only near maximum output. So watch the wattmeter as you force the bend to appear by increasing generator output. If the bend starts reasonably close to maximum rated output, it is caused by overdriving; but if it occurs considerably below maximum rated output, it is due to an underbias condition caused by some shifting of the operating characteristics of one or more stages. Be careful to take line voltage into account; when the line voltage is unusually low, the bend will appear considerably below rated output even in a perfect amplifier; while if the line voltage is much higher, it will appear around rated output in a bad amplifier. Often, excess distortion is due to nothing more serious than low line voltage.

The effect due to overbiasing or operation on the bend of a tube's curve, is indicated in *b* for the various shapes. The bend due to clipping is a very sharp one; the bend due to curvature is much more gentle, really a curve rather than a bend.

When the pattern is an ellipse or circle, curvature merely flattens the ends, whereas clipping turns them into straight lines. The crimp in the outside edge is more gentle and more kidney-shaped. When in doubt, however, you can always turn the scope to the internal sweep position, synchronize, and look at the sine wave. Clipping squares the top severely—in extreme cases makes a square wave out of the sine wave—while curvature merely spreads the peak, producing a wider bend.

The bend due to curvature may also be symmetrical or single-ended. Here too, the single-ended one can be due to

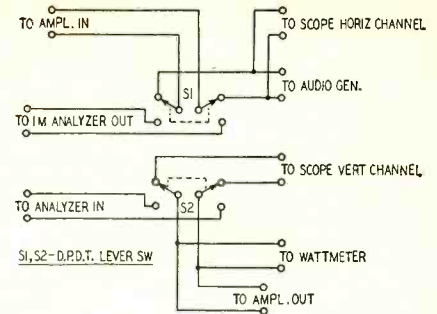

Fig. 2—A junction and switch box.

a single-ended stage or to an unbalanced push-pull stage, and the unbalance can be determined by the difference in the appearance of the two bends.

It is possible to have clipping on one end and curvature on the other end. This would appear when the operating point of a stage is very close to the middle of its operating curve. The positive peaks would be clipped when the grid turns positive; and the negative peaks would be curved when the tube gets close to cutoff. Although, theoretically, this should occur often,

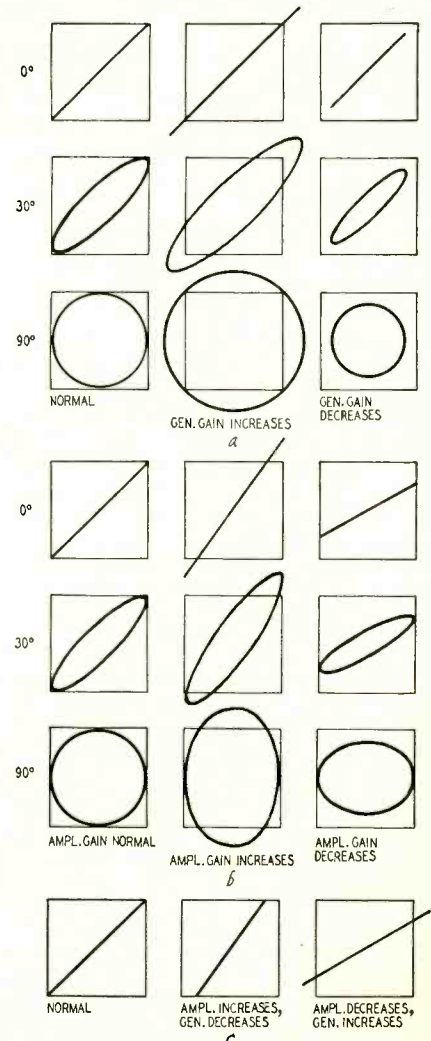

Fig. 3—Gain and phase angle patterns.

AUDIO—HIGH FIDELITY

in practice it seldom does, since few operating curves are that symmetrical. This form can also occur in a not very well balanced push-pull stage, especially one with a balancing control. In this case one half can be overbiased and the other half underbiased.

In high-fidelity amplifiers in which most or all stages operate class A and not beyond AB₁, clipping is likely to occur earlier than curvature. This is because in a class A stage the quiescent operating point is usually nearer the zero bias than the cutoff point. So if a curvature bend occurs before a clipping bend, an abnormal overbias condition is indicated.

In-phase distortion

The common forms of distortion are out-of-phase with the original signal; but there are some forms of distortion which are in-phase. These are indicated by a bend toward the inside of the square as shown in *c*. The shape of the bend is similar to that of curvature, but the direction is opposite; the figure will usually expand vertically a little, but this is not usually very noticeable. The single-ended type of in-phase distortion is sometimes found in amplifiers, like the Williamson, which use the split-load or cathodyne inverter. This happens if the output tube or amplifier driven by the cathode is overdriven hard enough to draw grid current. When this happens the cathode of the inverter is partially shorted. The result is that the plate-side gain increases to more than 1. This is easily spotted because shifting to the sine-wave pattern will show that the sine wave has a peak on it, instead of being flattened or squared.

Symmetrical in-phase distortion occurs normally only under class B operation and therefore is unlikely to be found in a high-fidelity amplifier. If it does show up, it indicates that the output-stage characteristics have shifted so severely as to throw the stage into or near class B operation. This could happen if the bias supply has gone haywire and has increased the bias voltage severely.

Figures in *d* indicate the changes in the pattern caused by transformer core saturation or magnetization. It will occur with almost any amplifier at half-power output or more below 40 cycles. If it happens far below maximum rated output it could be due to unbalance in the output tubes since this would cause the uncanceled d.c. in the primary to increase and thus produce earlier saturation and magnetization. The straight-line pattern is the least likely in this case because in most amplifiers there will be some phase shift below 50 cycles and the pattern will be an ellipse or circle. It is easily distinguished from all others by the extreme squaring off of two sides of the pattern. When the effect is really bad, you may get two parallel straight lines joined by curves or loops.

In *e* we have the effect of parasitics

or ringing. Very aptly the pattern acquires *riders* very similar to those which are produced on an i.f. alignment curve by the marker generator.

Many of these distortions can be found in any amplifier—even one in perfect operating condition. The difference is that in a good amplifier they appear only at or beyond the useful maximum output; whereas in an ailing one they occur very much earlier. A good way to familiarize yourself with the method is to put together a training amplifier with variable resistors or potentiometers in the cathodes and plate circuits; and to observe the traces as various operating conditions are varied.

One caution: Always be careful not to overdrive the scope amplifiers. For this reason I keep the size of the initial or reference square on a scope with a 7-inch face to 2 inches on each side, and I change attenuator setting when the pattern exceeds 4 inches on a side. For smaller scopes, a smaller initial square is called for. If you're not careful about this, the curvature you'll observe may be the result of the scope amplifiers, not the amplifier under test.

Analyzing the amplifier

Now then, let us run through a step-by-step analysis of an ailing amplifier with this method:

1. Set the generator at around 1,000 cycles and establish the reference line from corner to corner of the square.

2. Make a quick sweep of the whole audio spectrum at a low input and output level. Do this with the tone controls in their flat position. Observe the behavior of the trace. In today's good hi-fi amplifiers the phase shift from 1,000 cycles downward and upward will be small—usually the pattern will not pass beyond a narrow ellipse up to 10,000 and down to 50 cycles. Beyond those points the ellipse may expand into a circle, which indicates a phase shift of 90°.

You might think that since an amplifier is said to be flat within this range, the line ought to remain straight and not open into an ellipse. However, keep in mind that the input capacitor of any amplifier is outside the feedback loop, and although one time-constant does not produce a great phase shift it does produce some. Furthermore, you can have a constant and gradual phase shift from one end of the range to the other without a significant change in gain or flatness. If the phase shift does not go beyond a circle at the two extremes, the situation is all right. But if it goes beyond a circle and approaches a straight line inclined in the other direction, which would be a phase shift of 180 degrees, there is serious danger of instability, motorboating, ringing, and a poor transient response.

3. You can check for such instability by increasing generator output at 20 cycles and 20,000 cycles. Be sure to change the attenuators on the scope.

The presence of high-frequency ringing will be seen by riders on the patterns; low-frequency motorboating will produce a violent distortion of the trace. If neither of these things happen up to maximum output you can assume the amplifier is stable at all frequencies. If there is evidence of instability, make a note of it and deal with the problem later as I detailed in the previous chapter on IM analysis.

4. Determine how bad the distortion is. Return the generator to around 1,000 cycles and, remembering to change the attenuator settings, increase the generator output and amplifier gain, if necessary, until you obtain evidence of some kind of distortion. Determine by watching the wattmeter, or by interpreting the output voltage as read on a voltmeter, at what point in the dynamic range the distortion occurs. If it occurs only at or near maximum output, the amplifier is in pretty good shape; and balancing and a change of tubes ought to bring it around to good condition. But if it occurs at a lower output level, something is seriously wrong.

5. Analyze the type of distortion from the illustrations and descriptions I have given. If necessary to make sure of the type, shift the horizontal channel of the scope to internal sweep and examine the sine wave. Note whether the distortion is overdrive or curvature type, single-ended or symmetrical.

For instance, suppose you get a sharp, overdrive type bend at half-rated output. This would indicate a single-ended stage being overdriven because it is underbiased. To check, increase the generator output to see if you can produce another bend in the other end. If you do not get it up to or near maximum output, you're pretty safe in deciding it is in fact a single-ended stage that's causing trouble.

But suppose that by driving the amplifier a little harder you get another similar bend on the other end. You know now it cannot be single-ended because a single-ended stage won't clip both positive and negative peaks. So the indications are that it is an underbiased and unbalanced push-pull stage. You can judge the amount of unbalance by noting how much additional input voltage is necessary to produce the second bend.

What if driving harder produces a curvature bend on the other end? A little reflection will show you that two things could account for this: First, it could happen with a single-ended stage—the overdrive-type bend being produced when the positive peak is clipped, and the curvature-type bend being produced when the negative peak reaches the knee of the curve. You can judge how far the quiescent point is from the center of the operating curve by noting how much difference in input voltage is necessary to produce the second bend. Actually this condition is not likely to occur unless the

plate voltage supplied to the single-ended stage has for some reason been seriously reduced. In a well-designed amplifier, overdrive of a single-ended stage should occur only at maximum rated output, and the curvature bend would then be unlikely to show up until way past maximum rated output. So, here you have a pointed indication of a faulty filter capacitor, bad rectifier, shorted decoupling resistor or plate load, etc.

The appearance of a trace with an overdrive bend on one end and a curvature bend in the other could occur in a push-pull stage which has a balancing potentiometer across both cathodes. A misadjustment of such a potentiometer would underbias one side, overbias the other, and produce the asymmetrical double-ended bend. A push-pull stage in which the two tubes have separate bias resistors also could produce this effect if one tube draws much more current either because the bias resistor is too low, because the tube itself is abnormal, or because the plate load has changed or has been partially shorted. Since it is almost impossible that a single amplifier would have all three types of amplified stages, a look at the circuit diagram should make it possible to put the finger on the most likely possibility.

If the output stage has a balancing potentiometer, you can check that possibility by adjusting it. If the distortion is really produced in that stage, changing the balancing adjustment will change the pattern, removing one or both bends, or transposing them. Even if the potentiometer doesn't affect the bends, you can adjust balance, which will be indicated by making the line straight again; by putting similar bends on both ends; or by a point at which the line or pattern is narrowest and least deformed. The last situation is almost conclusive proof that a single-ended stage is involved. In this case a point will be found in varying the balance control at which the pattern will open and close. The bend will remain, but as you move the potentiometer slightly on each side, the pattern will tend to open. The proper setting is at the point where the pattern is most completely closed. If you observe the wattmeter you will see that this point also produces maximum output with a given input signal, another indication of good balance.

6. Now that you have some idea of the trouble and its seriousness, and location, you can open up the amplifier and examine the stage which is the most likely offender. If your scope permits push-pull input, so much the better. If not, you will have to look first at one side and then at the other; and you'll want to do this in any case when the push-pull stage is the offending one, since the trouble usually is in one side only.

7. When you have definitely isolated the stage, you can proceed with ohmmeter and v.t.v.m. to determine the

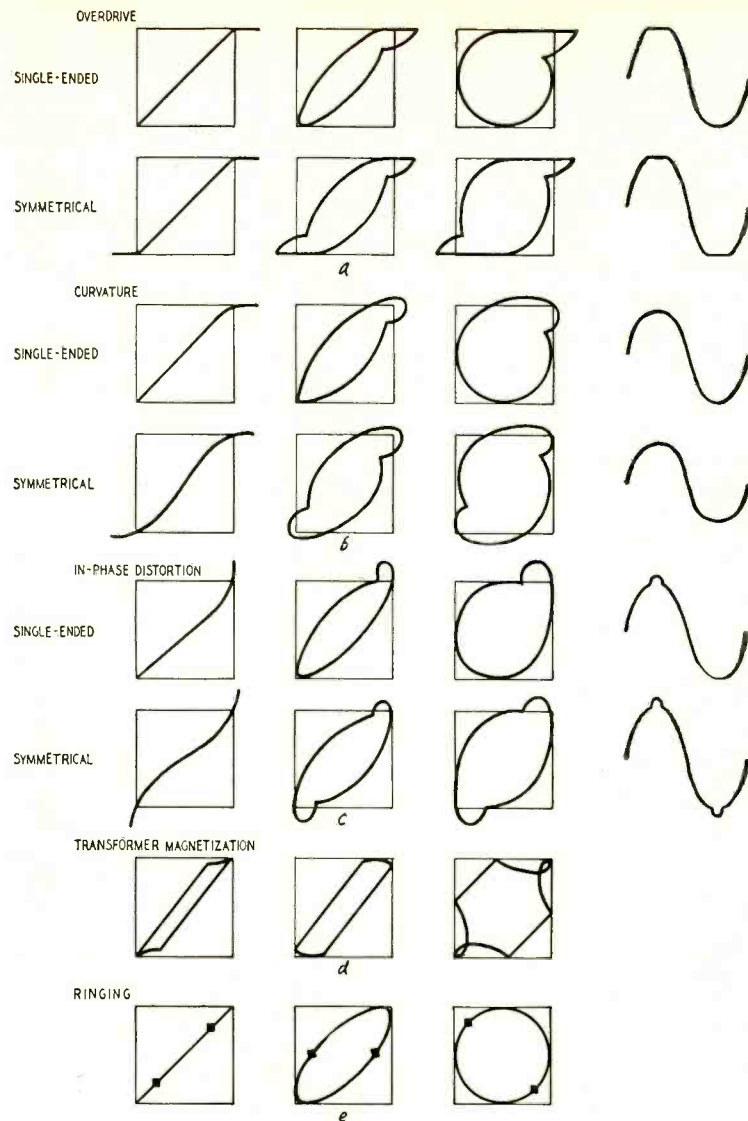

Fig. 4—Various distortion patterns.

exact trouble. The scope will give you an immediate indication of improvement or worsening as you make adjustments or changes.

8. Having reduced the distortion in the offending stage so that it no longer occurs or only at or beyond maximum rated output, it would be wise to take an IM reading to see if there are any other, smaller troubles. If not, balance the amplifier, with the scope trace if you like. If you do balance with the trace, take IM readings both at maximum output and a low output. Sometimes balancing at maximum output like this will unbalance the stage at lower levels. In that case, rebalance, using a voltmeter, plate to plate, for an indicator.

9. Make another frequency run at low levels; and then one at or just below maximum output. In the first instance watch to see that the response is flat and the phase shift small; in the latter, see if the distortion remains fairly constant as the frequency is varied.

10. If the amplifier has tone controls you can set them for the flattest re-

sponse. Set the generator at 50-60 cycles and boost or attenuate with the bass control to produce the straightest line or narrowest oval; do the same with the treble at 10,000 cycles. Mark these positions for the benefit of the customer; or, if you like, loosen the set-screws on the knob and reset them so the pointers are at the flat position.

11. If your audio generator permits a square-wave output, it won't take over a couple of minutes to check the response to square waves at 20, 60, 1,000, 10,000, and 20,000 cycles. This will give you a good idea of the amplifier curve below and above audibility. If the waveform is fairly good at 60 and 10,000 cycles—with not over a 50% slope at 50 cycles and neither too much ringing nor too much rounding-off at 10,000 cycles, the job is flat enough for hi-fi use.

This would complete the job of testing and checking. Although it seems complicated, familiarity will bring speed with it. No other method is so rapid. A good man can test, diagnose, repair, and adjust an amplifier in less than an hour. (TO BE CONTINUED)

HIGH-FIDELITY LOUDSPEAKERS

Part IV—The enclosure, cabinet, or baffle can be a decisive factor

By H. A. HARTLEY*

EVERY loudspeaker making any pretensions to providing high-fidelity reproduction must be mounted in a way that agrees with its design. Horn-loaded speakers obviously must be loaded with a horn, but direct radiators can be mounted in various types of housings. Not all are equally good, nor can any particular design be chosen as the best mounting for any given speaker. The housing must be designed for the unit which will work in it. The only exception to this rule is the original and simplest mounting—the flat baffle—and it is now generally recognized that this is not the best design, with the sole exception of a hole in the wall. That is very nearly perfect, if the back of the wall is not obstructed.

The baffle

The effective size of any baffle is the shortest path from the edge of the cone in front of the baffle board to the edge of the cone behind the board. Under certain circumstances the speaker can be deliberately mounted off center to reduce interference patterns in the sound waves, but this is a type of ex-

periment that can be done only by trial and error, the mathematical analysis being hopelessly involved. The larger the baffle the better the bass response. Fig. 1 gives the bass loss at various frequencies for different sizes of baffles. Intermediate sizes can be interpolated.

The baffle must be made of thick material. Wood, well braced and backed with sound-absorbent material for deadening purposes, is as convenient as anything. The thickness must be increased with increased size, for the vibration from the speaker can set the baffle in motion at its own natural frequency—it acts like the skin of a drum. The front edge of the speaker cone should be in the same plane as the front of the baffle, for even the short tunnel of the baffle opening can impair results. If the baffle is placed across the corner of a room, the sides should not touch the walls; otherwise air-column resonance will be set up in the triangular space behind the baffle. By the same token, a speaker mounted in a hole in the wall should play into another room, not into a cupboard.

The baffle need not be flat. It can be "bent"—even to the point where it becomes a box with open back. The effective size is still the shortest distance from the front to the back of the cone, and the diagram for bass cutoff given for flat baffles (Fig. 1) still applies. However, with a box baffle, complications creep in. If the speaker has no bass resonance—and very few have none—the flat baffle performance will be as shown in the diagram; if it is mounted in a box, two additional resonances will be generated. One is the resonance of the enclosed air; the other is the resonance of the box itself, which is more pronounced than with a flat baffle. The deeper the box the more pronounced is the air-column resonance.

Lining the box with absorbent ma-

terial will help to deaden box resonance, but it seems to be very difficult to convince some people that this does nothing to kill the air-column resonance. This latter is resonance of the air itself, and it can be overcome only by introducing specially designed absorbent screens or by eliminating the air. Such is clearly impossible, but an equivalent effect can be got by packing the whole of the interior space with lightly compressed sound-absorbent material. A recently published book on high-fidelity reproduction states that "such . . . resonance can be eliminated simply by closing the rear opening of the box, thus completely enclosing the loudspeaker." Such a statement cannot be justified. If there is air inside the box, open or closed, it will resonate at its own natural frequency when set in motion by the movement of the speaker cone.

A unique method that I developed uses what are, in effect, acoustical filters. Fig. 2 shows a section of the

*H. A. Hartley Co., Inc.

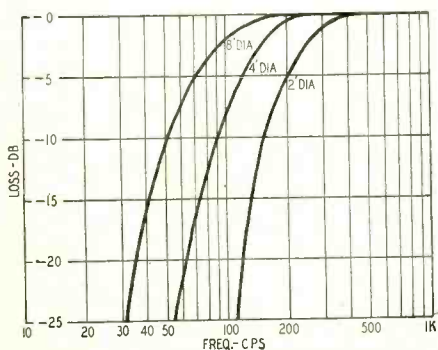

Fig. 1—Bass loss with finite baffles.

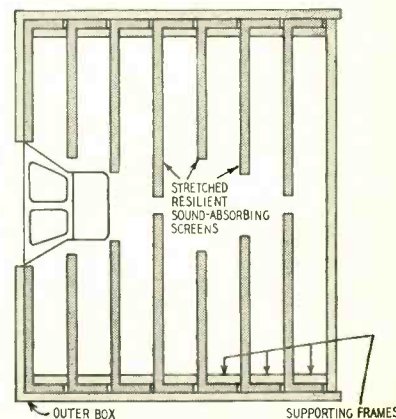
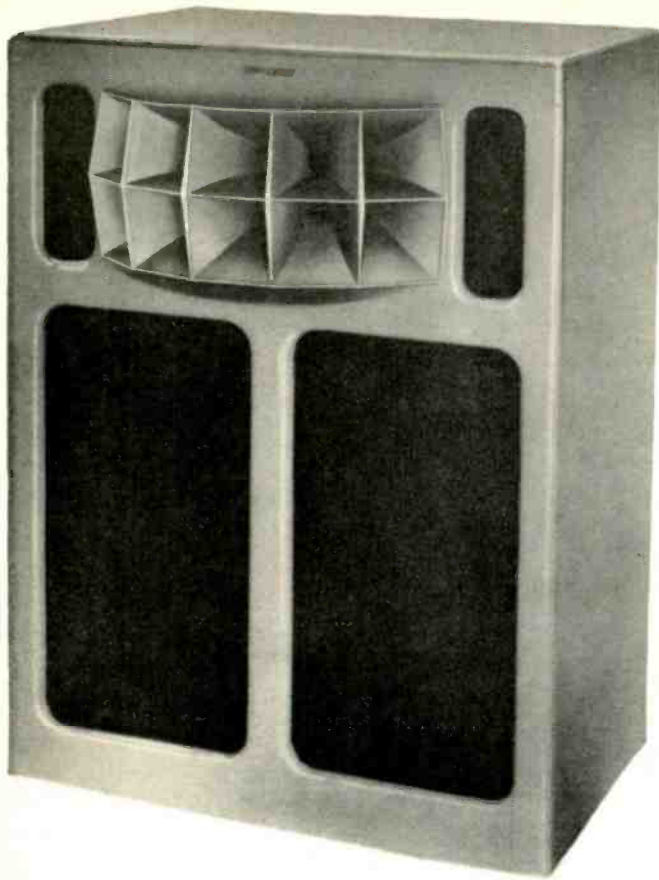
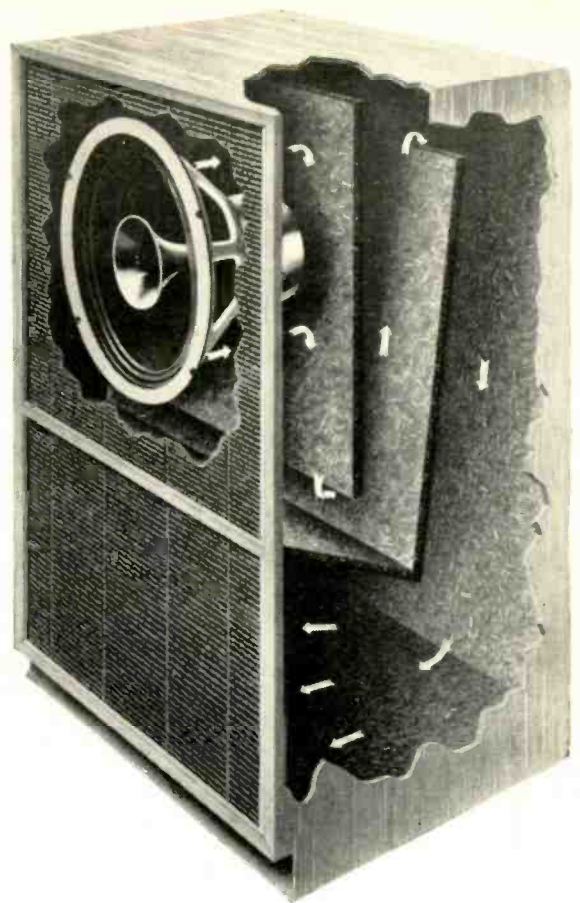

Fig. 2—The author's nonresonant box baffle makes use of acoustic filters.



Stephens enclosure with tweeter horn.



Stromberg-Carlson speaker enclosure using an acoustic labyrinth. Arrows show air path from rear of the cone.

speaker box in which there are two series of sound-absorbing screens. The screens are made up of absorbent material stretched across wooden frames, the material being carried around the frames so that it is nipped between the frames and the cabinet. This dodge not only keeps the screens in place but damps out vibration in the sides of the box. The distance between screens should be about 2 inches, and the back of the box is not closed. The scheme can be used in any square or rectangular container; the effective baffle area is about half as great again as an ordinary unfilled box, and there is neither air-column resonance nor cabinet resonance.

Electrical filters are made up of inductors, capacitors, and resistors. The components of acoustic filters are masses, springs, and friction. In this design, the air between the screens forms the masses, the stretched screens themselves are the springs, and the absorbercy of the screens represents the friction. The holes in the screens, tapering in size, control the slope of the filter; Fig. 2 shows a two-stage filter. The action is somewhat as follows: The enclosed air is broken up into small sections, each of which has a rather high resonant frequency. The energy of the moving air in each section is absorbed by the screen immedi-

ately behind it. The first section gets the greatest impact from the moving air, so the first screen has a rather large hole to allow most of the moving air to escape into the second section; the smaller hole in the second screen allows the same *proportion* of air to escape into the third section, and so on, to the end of that stage in the filter. The process can be repeated several times if the cabinet is so deep as to form a real tunnel.

Absorption of the lowest frequencies can be made complete, but experience has indicated that a total volume of about 4 cubic feet is all that is necessary for a 10-inch speaker. The box should not be placed closer than 4 inches from a wall.

Completely closed boxes, so-called infinite baffles, have quite different properties. As already explained, the enclosed air will resonate at its own frequency and this produces a peak in the impedance curve of the speaker. Standing waves inside the box cannot be absorbed by soft lining, because their wavelength is much greater than the thickness of the lining. A perfectly smooth surface reflects a sound wave perfectly, a soft absorbent surface will absorb a wave up to the limit of its absorption movement. Properly designed anechoic test rooms have a lining some feet deep, usually arranged in

wedges to break up the standing waves. The thin lining of a closed box can only help to deaden the box structure itself.

If the box is so dimensioned that the enclosed air resonates at some frequency which makes good a lack of response in the speaker, then the air-column resonance can be turned to good purpose; apart from this the presence of it is nothing more or less than a nuisance. In particular the air-column resonance must not coincide with the bass resonant frequency of the speaker, otherwise distortion and boom at this frequency will be very bad. The simple rule is that the box size should increase as the speaker resonance falls. Some suitable figures are given:

Speaker bass resonance in c.p.s.	80	70	60	50	40
Box size in cubic feet	1.5	2	3	5	10

Cabinets

Phase-inverter or bass-reflex housings are deservedly popular because they minimize one of the most common defects in speakers—the bass resonance due to tight suspension. On the other hand, if the selected speaker has no bass resonance, a phase-inverter cabinet will spoil its performance. This

AUDIO—HIGH FIDELITY

type of housing can be used as a carefully designed cabinet for a given speaker, when it is called a matched phase-inverter, or it can be used in an unmatched condition, when it is not designed to fit the speaker but is adjusted to make a pleasant noise. These applications must be considered separately.

A matched phase inverter improves the bass, decreases the bass-resonance impedance, increases power-handling capacity above the bass-resonant frequency, and reduces the movement of the cone at bass resonance. The construction must be substantial and free from resonances in the component parts of which it is made. As with a horn the ideal construction would be precast concrete, but this is inconvenient for household use. The port opening should have the same area as the speaker diaphragm, and the tunnel behind the port may be as short as the thickness of the front of the cabinet or as long as 1/12 wavelength of the bass-resonant frequency; the length of the tunnel affects the design of the cabinet. If the cabinet is too small it will behave as a completely closed box. Regardless of how it is designed it will have two defects inherent in the idea: introduction of two resonant peaks, above and below the bass-resonant frequency, and phase shift at resonant frequency.

There will be loss of treble through reflections and absorption; a single wide-range speaker used in such a cabinet therefore will not be as good as on a flat baffle. However, if the phase-inverter is used to house a bass unit, this is an advantage, and the interior may well be lined with soft material to provide a further treble loss; this will, in some small degree, help to reduce phase distortion at crossover frequency. Design of the complete housing is simple, using the following equation:

$$V = \pi r^2 \left(\frac{1.84 \times 10^8}{(2\pi f)^2} \times \frac{1}{1.7r + 1} + 1 \right)$$

where V = volume in cubic inches; r = radius of cone in inches, l = length of tunnel in inches, f = vent resonant frequency (which can be taken as the speaker bass-resonant frequency). The vent area is obviously equal to πr^2 .

If internal bracing is used to strengthen the cabinet, allowance must be made for the volume of this in computing the total volume, and it must be remembered that the figure for volume is the volume of enclosed air, not the external size of the cabinet.

The unmatched phase inverter is, as indicated, an experimental device, in which the resonances of the cabinet are used to fill out defects in the speaker response or to introduce some synthetic bass to give body to the reproduction. Some reasonable size of cabinet is selected, the tunnel is predetermined, and adjustable vents are used to get the desired effect. Once the cabinet has been built, the vent is the only way

of altering the speaker characteristics.

From the outside, an acoustic labyrinth looks like a phase inverter in that there is a speaker at the top and a hole at the bottom; generally, however, the speaker will be displaced from the center and the bottom opening will be larger than a bass-reflex port. The acoustic labyrinth behaves like an organ pipe. It is of little importance how the pipe of the labyrinth is shaped, provided the form is as simple as possible. Whether the enclosure is called a labyrinth, an air column, or something else, it is virtually putting the speaker at the end of a wooden pipe of constant cross-section. For minimum distortion the construction should be as simple as possible, and as rigid as possible, and the length of the pipe should be one-quarter of the wavelength of the bass-resonant frequency of the speaker. The unique property of the acoustic labyrinth is that it lowers the bass-resonant frequency of the speaker; all other cabinets dependent on acoustic jugglery raise it to a greater or lesser extent.

Folded horn enclosures *must* be

properly designed to be effective; if they are not, electroacoustic efficiency will be impaired, phase distortion will be excessive, and harmonic distortion will be generated in the throat, and the sound chamber will undo all the good that might result from good design. Constructional diagrams of the better-known folded horns have appeared many times and there is no need to repeat them here; the mathematical design is beyond the scope of the present series. For those who wish to design their own horns the following basic formulas apply:

Exponential horns. $A = A_e e^{mx}$ where A = area of cross-section (in any convenient unit of area) at any point x feet along the axis; A_e = area of throat (in the same units); e (epsilon) = 2.71828; m = flaring constant (which determines the total bulk of the folded horn).

Hyperbolic exponential horns. $A = A_e (\cosh mx + S \sinh mx)^2$ where the symbols are the same as in the previous formula and S is the shape parameter, which may be anything from zero to infinity. A usual value is between 0.5 and 0.7. (TO BE CONTINUED)

High Fidelity for TV

GOOD sound reproduction is as important in some respects as a sharp, linear picture for real enjoyment of television, especially musical programs. Yet this is one of the weakest points in most television receiver designs. Audio circuits provide a bare minimum of performance; speakers are small and poorly placed; tone controls usually are absent. This is especially regrettable since the general quality of the sound signal received is fully worthy of a good wide-range audio system.

The diagram shows a way to improve this situation. The assembly uses an AM-FM tuner chassis with built-in high-fidelity audio, operated by remote control from the TV chassis. Any high-quality radio receiver (or audio amplifier) can be used as the tuner.

The controls are simple and fool-proof. The tuner can be turned on with its own switch (without turning on the TV) and AM, FM, or phono can be selected with the regular tuner selector switch.

When the TV switch is turned on, the plate current of the otherwise unused TV audio output tube actuates the double-pole double-throw relay. One section of the relay turns on the

117-volt power for the tuner and the other section switches in the TV audio signal. This relay section is so placed that when the TV set is on, sound is obtained regardless of the setting of the tuner selector switch. The tuner tone control, between the first and second audio stages, functions for TV, FM, AM, or phono.

The value of R can be chosen to give proper operating current for whatever relay may be desired or available. Placing the relay in the cathode circuit of the output tube keeps all connecting cables between the two chassis at low potential. (Special precautions may be needed to prevent hum pickup from the a.c. lines wired to one set of contacts on the relay. We suggest using a relay with wide separation between the individual switching sections. Use shielding braid on the a.c. leads between the line switch on the tuner and the relay contacts.—Editor)

In the event that either the TV set or the tuner uses a transformerless power supply, a common ground should be avoided. The shield of the grid wire can be brought to a.c. ground potential by grounding it through a .05- μ f 600-volt capacitor.—Stanley I. Rowson

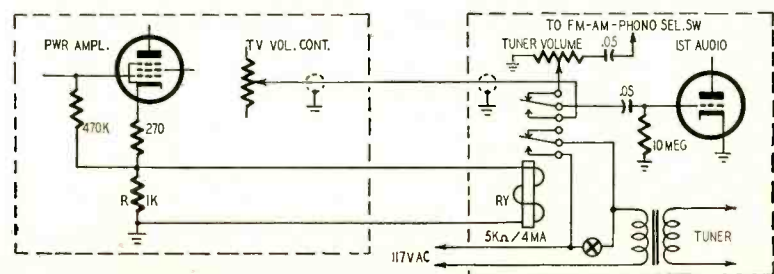

**It's New! 3 Years in Development
-NOW READY FOR YOU!**

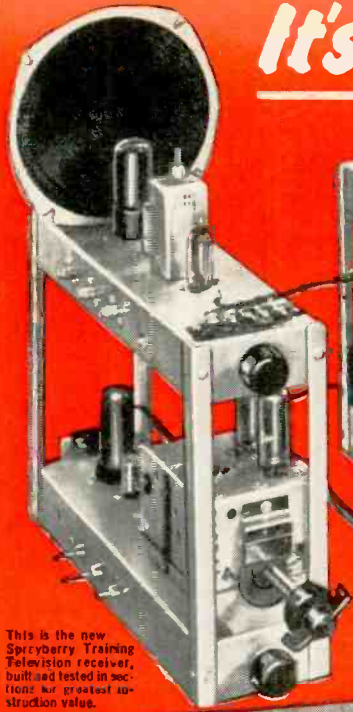

This is the new Sprayberry Training Television receiver, built and tested in sections for greatest instruction value.

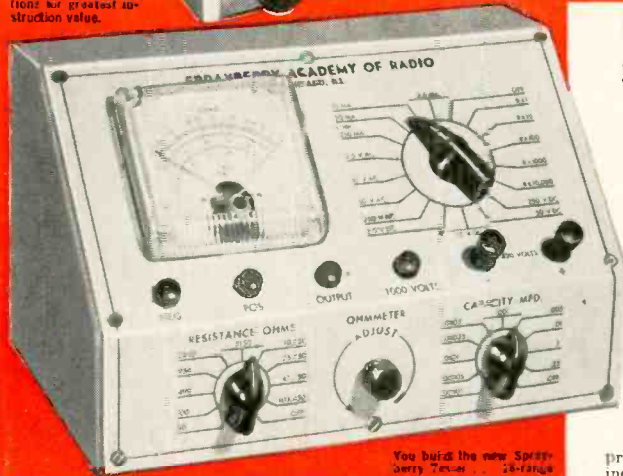
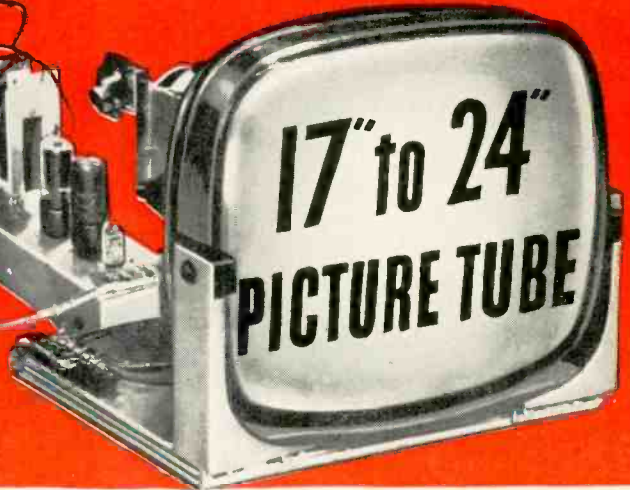
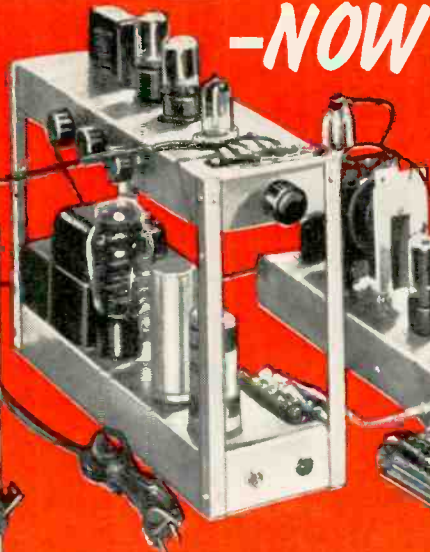

These photos show only a small part of the training equipment I send my students.

You build the new Sprayberry Test Set - 50-25000 Volt-Ohm - Milli-ammeter readings plus output meter and condenser and resistor substitution selector.



You will build this powerful short wave and broadcast superhet radio receiver for valuable shop instruction practice.

New Equipment! New Lessons! Enlarged Course!
SPRAYBERRY PRACTICAL TRAINING IN
RADIO-TELEVISION
3 NO OBLIGATION TRAINING PLANS



Frank L. Sprayberry
President, Sprayberry
Academy of Radio

You have NO MONTHLY PAYMENT CONTRACT to sign ... pay for this outstanding training as you learn!

The complete facts are so big and so important to any man seeking training in Radio-Television that I urge you to mail the coupon below at once for my big all-new 56 page **FREE CATALOG** and **FREE Sample Lesson**. Get the full story of this remarkable new and up-to-the-second Training Plan. You'll read about my 3 **NO OBLIGATION PLANS** or "packaged unit" instruction for both beginners and the experienced man. You'll learn how I can now prepare you in as little as 10 **MONTHS** to take your place in this fast moving big money industry as a Trained Radio-Television Technician. You'll see that you take no risk in enrolling for my Training because you **DO NOT SIGN A BINDING TIME PAYMENT CONTRACT**. I have been training successful Radio-TV technicians for 22 years . . . I can prepare you, too, to get into your own profitable Service Shop or a good paying job, even if you have no knowledge of Radio-Television. Mail the coupon . . . I rush full information **FREE** and without obligation. (No salesman will call.)

NEWEST DEVELOPMENTS

Your training covers **U H F, Color Television, FM, Oscilloscope Servicing, High Fidelity Sound and Transistors.**

PRACTICE AND TRAIN AT HOME WITH 25 NEW KITS OF EQUIPMENT

You get valuable practical experience in construction, testing and shop practice. You build a powerful 2 band superhet radio, the all-new 18 range Sprayberry multimeter, the new Sprayberry Training Television receiver, signal generator, signal tracer and many other projects. All equipment is yours to use and keep . . . and you have practically everything needed to set up a Radio-Television Service Shop.

All your training is **IN YOUR HOME** in spare hours. Keep on with your present job and income while learning. I help you earn extra spare time money while you learn. If you expect to be in the armed forces later, there is no better preparation than practical Sprayberry Radio-Television training. Rush coupon below for all the facts—**FREE!**

SPRAYBERRY ACADEMY OF RADIO
111 NORTH CANAL STREET, DEPT. 20-M, CHICAGO 6, ILLINOIS

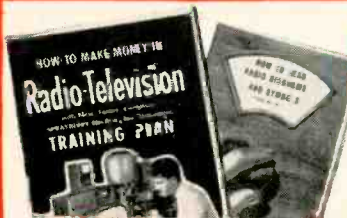

FREE CATALOG AND SAMPLE LESSON

Rush coupon for my catalog "How to Make Money in Radio-Television". **PLUS** an actual sample Sprayberry Lesson without obligation—**ALL FREE**. Mail coupon **NOW!**

SPRAYBERRY ACADEMY OF RADIO MAIL THIS COUPON FOR FREE
Dept. 20-M 111 N. Canal St., Chicago 6, Ill. **FACTS AND SAMPLE LESSON**

Please rush all information on your **ALL-NEW** Radio-Television Training Plan. I understand this does not obligate me and that no salesman will call upon me. Include New Catalog and Sample Lesson **FREE**.

Name _____ Age _____

Address _____

City _____ Zone _____ State _____



low-noise transistor preamplifier

The new CK727 insures both quiet operation and high voltage gain

By RUFUS P. TURNER*

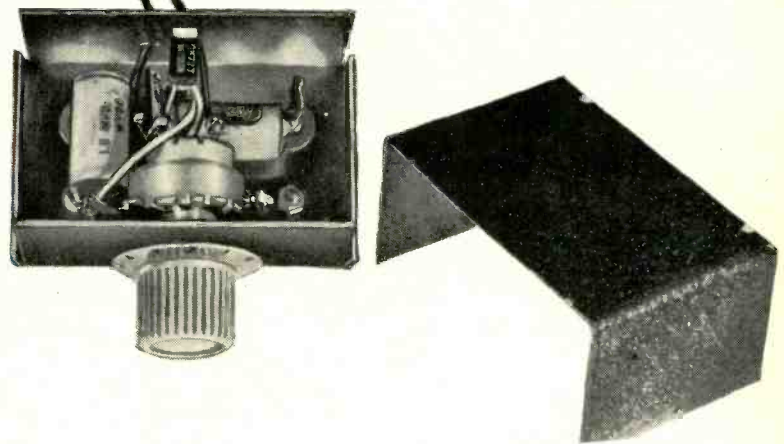

ALTHOUGH the junction transistor in the common-emitter circuit always has offered attractive possibilities as a high-gain, single-stage, nonmicrophonic, single-battery, voltage preamplifier, there has been some objection to its use because of the inherent high noise level of the transistor. When operated ahead of a main amplifier having high voltage gain, this noise voltage has appeared

Fig. 1 shows a common-emitter preamplifier circuit which I found optimum for my particular requirements. This resistance-capacitance-coupled arrangement is designed to operate into a high impedance, such as an a.c. vacuum-tube voltmeter or the grid circuit of an amplifier, which will allow full use of the preamplifier voltage gain.

For the transistor tested, voltage gain at 1,000 cycles is 93. The maximum 1,000-cycle input-signal voltage before rounding of the positive peaks of the output signal is 10 millivolts. Output voltage is 0.93 volt across 1 megohm connected to the amplifier output terminals. The measured input impedance at 1,000 cycles is 7,500 ohms (output impedance of the signal generator used was 600 ohms, resistive). The noise voltage, measured with a vacuum-tube a.c. millivoltmeter at the amplifier output terminals, was 3 millivolts with the input terminals short-circuited. This is 49.8 db below maximum signal-voltage output.

Fig. 2 shows the frequency response of the single-stage amplifier when worked into a 1-megohm load resistor connected to the output terminals. Response is constant from 500 to 5,000 cycles, and is 1.66 db down at 50 cycles and 3.75 db down at 50 kc. It is 1.29 db down at 20 kc. This curve was plotted with a constant 10-mv input signal and with the amplifier gain control set at maximum output.

A single 4.5-volt battery powers the

amplifier. Since the current drain is only 100 microamperes d.c., this can be a miniature battery, for example three 1.5-volt penlight cells connected in series. The battery switch can be operated by the volume-control potentiometer. I used small metallized-paper 1- μ f coupling capacitors for C1 and C2. For compact installations, however, these components may be miniature tantalum electrolytic capacitors. If the latter are used, the positive

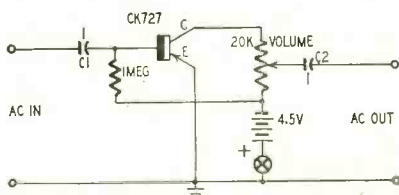

Fig. 1—Common-emitter preamplifier.

as an annoying hiss in the final output.

The new Raytheon CK727 p-n-p transistor has a lower noise factor (18 db maximum in the common-emitter circuit with 1.5 volts collector potential) than previous high-alpha units. In other respects, the room-temperature characteristics of this new transistor are similar to those of the CK721 in the 1.5-volt common-emitter circuit, except for a collector resistance in the CK727 of 1 megohm, base resistance of 800 ohms, and cutoff current of 5 μ a.

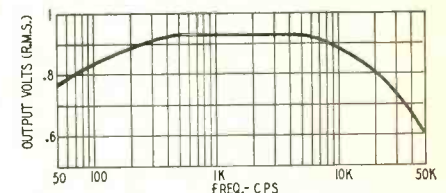

Fig. 2—Amplifier frequency response.

terminal of C1 must be connected to the top a.c.-input terminal, and the positive terminal of C2 to the top a.c. output terminal.

It is a comparatively simple matter to build this preamplifier into a test probe, microphone case, stethoscope pickup, or similar accessory requiring high voltage gain with few components, freedom from the power line, and a simple circuit. Its low power drain (around 500 microwatts d.c.) makes it economical to operate for long periods and prevents the mortal sin of forgetting to turn it off. **END**

*Author, *Transistors, Theory and Practice*.

BUILD YOUR OWN

Heathkits



- TEST INSTRUMENTS
- AMPLIFIERS
- RECEIVERS, etc.

- ① Save by ordering direct from manufacturer.
- ② All high quality standard brand components.
- ③ Increased knowledge through actual construction.
- ④ Sound engineering insures excellent performance.
- ⑤ Kit construction is fascinating and enjoyable.



MODEL O-9
\$59⁵⁰
Shipping
Wt. 28 lbs.

Heathkit MODEL O-9 OSCILLOSCOPE KIT

New features unheard of in a kit oscilloscope have been added to the already popular Heathkit series. All top quality components are used including a brand new RCA 5U11 CRT. Ten other first line tubes complete the lineup. Voltage regulation provides a rock steady pattern regardless of normal line voltage variations. A built-in blanking amplifier eliminates the retrace line entirely. Other important advantages are a phasing control, Z axis input, direct connections to the deflection plates, 1 volt peak-to-peak calibration voltage and a calibrated grid screen.

Wiring is simplified by the use of the harness technique which also results in a neat professional appearance. Extremely wide vertical bandwidth allows accurate reproduction of even a 500 KC square wave. Excellent focusing characteristics are made possible by the use of the new RCA 5U11 CRT and a spot shape control. One of the most versatile of test instruments, the Heathkit O-9 Oscilloscope will be invaluable in the radio and TV service shop, as a work project in schools and for all types of circuit investigation work in the laboratory. Its new features make Model O-9 comparable in every way to many commercially built oscilloscopes selling for as much as \$400. Don't pass up this opportunity to add a really fine instrument to your service or experimental lab.

Heathkit

VOLTAGE CALIBRATOR KIT

The use of a Voltage Calibrator will greatly increase oscilloscope usefulness. Provides a convenient method of making peak to peak voltage measurements by establishing a relationship between the unknown wave shape and the Voltage Calibrator. Voltage ranges .01-100 volts peak to peak. The Voltage Calibrator features direct reading scales and a regulated power supply system.



MODEL VC-2
\$11⁵⁰
Shipping
Wt. 4 lbs.

Heathkit

ELECTRONIC SWITCH KIT

The Heathkit Electronic Switch Kit will further extend scope usefulness by permitting simultaneous observation of two individually controlled traces. Continuously variable switching rates 10 cps to 2,000 cps in three ranges. Will also serve as a square wave generator over the range of switching frequencies.



MODEL S-2
\$23⁵⁰
Shipping
Wt. 11 lbs.

Heathkit VACUUM TUBE VOLTMETER KIT

The beautiful new 1953 Heathkit Model V-6 VTVM, the world's most popular kit instrument, now offers many outstanding new features in addition to retaining all of the refinements developed and proven through the production of over 70,000 VTVM kits. The Heathkit VTVM now features extended voltage ranges with 50% greater coverage on the DC range. New 1½ volt low scale provides well over 2¼ inches of scale length per volt permitting faster measurements with greater accuracy. AC and DC ranges are 0-1.5-5-15-50-150-500-1500 volts (1,000 volts maximum on AC). Ohmmeter ranges are X1, X10, X100, X1,000, X10K, X100K, X1 meg. Measures .1 ohm to 1,000 megohms. Other features are db scale, center scale zero adjust and polarity reversal switch. High 11 megohm input resistance virtually eliminates circuit loading.

The low anti-inflation price of this tremendously popular kit includes all tubes, necessary constructional material, test leads and the construction manual.



MODEL V-6
\$24⁵⁰
Shipping
Wt. 6 lbs.



Heathkit AC VACUUM TUBE VOLTMETER KIT

MODEL AV-2
\$29⁵⁰
Shipping
Wt. 5 lbs.

A new amplifier type AC VTVM that makes possible those sensitive measurements so essential in laboratory or audio work. Ten voltage ranges covering from .01 RMS full scale to 300 volts RMS full scale. Input impedance 1 megohm with frequency response 20-50,000 cycles. Ten DB ranges from -52 to +52 DB. Four diodes in meter bridge circuit for maximum linearity.



Heathkit

HANDITESTER KIT

MODEL M-1
\$14⁵⁰
Shipping
Wt. 3 lbs.

The ever popular Handitester is now supplied with a Simpson 400 microampere meter movement. Provides AC and DC voltage ranges 0-10-30-300-1,000-5,000 volts. Ohmmeter ranges 0-3,000 and 0-300,000 ohms. DC current measurements 0-10 and 0-100 milliamperes. A completely self contained portable instrument.



HEATH COMPANY • Benton Harbor 20, Mich.

HEATHKITS for the ENGINEER

Heathkit VISUAL AURAL SIGNAL TRACER KIT

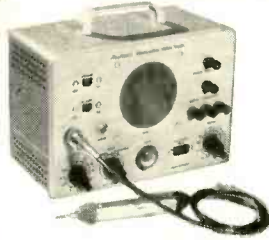

MODEL T-3 **\$23⁵⁰**

Shipping
Wt. 10 lbs.

Designed especially for service applications in AM-SW-FM-TV repair work. RF and audio two channel input. More than adequate sensitivity—new noise locator circuit—calibrated wattmeter—substitution speaker—visual signal indication. Can be used with scope and VTVM, checks phono cartridges, phono mechanisms, microphones, tuners, etc. Let the Heathkit Visual Aural Signal Tracer help you.

Heathkit CONDENSER CHECKER KIT

An instrument designed solely for its particular job. Not a "sideline" or a multiple function instrument. Measures value and quality of unknown condensers and resistors. Capacity range .00001 mfd to 1,000 mfd. Resistance range 100 ohms to 5 megohms. Sensitive electron beam indicator—five polarizing test voltages—safety spring return leakage test switch. An amazingly accurate instrument at this low price.



MODEL C-3
\$19⁵⁰ Shipping
Wt. 8 lbs.

Heathkit SIGNAL GENERATOR KIT



MODEL SG-8
\$19⁵⁰

Ship. Wt. 8 lbs.

The standard service instrument for alignment work. .1 volts output from 160 KC to 110 MC. Calibrated harmonics up to 220 MC. Internal (400 CPS) and external modulation. Pre-calibrated coils for all 5 bands. Good stability and accuracy. All test leads included.

Heathkit GRID DIP METER KIT



MODEL GD-1B
\$19⁵⁰

Ship. Wt. 4 lbs.

One hand operation. 5 pre-wound coils cover 2—250 MC. Controlled sensitivity. Usable as an oscillator or an absorption wavemeter. Extra low frequency coils available.

Heathkit LABORATORY REGULATED POWER SUPPLY KIT



MODEL PS-2
\$33⁵⁰

Ship. Wt. 20 lbs.

A regulated variable 160-450 volt DC output power supply for the lab or service shop. Accurate voltage and current measurements with large Simpson meter. AC supply 6.3 volts at 4 amperes—standby switch eliminates warmup time. Low hum content—5 tube circuit. AC and DC output voltages isolated from panel for maximum operational flexibility.

Heathkit RESISTANCE SUBSTITUTION BOX KIT

MODEL RS-1

Ship. Wt. **\$5⁵⁰**
2 lbs.



Choice of 36 switch selected resistance values 15 ohms to 10 megohms. All standard RTMA 1 watt 10% resistors. Buy several for those lab and service applications.

NEW Heathkit 20,000 OHMS PER VOLT MULTIMETER KIT

Here is the solution to all service problems requiring a portable measuring device of high accuracy. 20,000 ohms/volt sensitivity on DC and 5000 ohms/volt on AC. Full scale voltage ranges of 1.5, 5, 50, 150, 500, 1500 and 5000. DC current ranges of 150 microamperes; 15, 150 and 500 milliamperes; and 15 amperes. Resistances are measured from .2 ohms to 20 megohms in 3 ranges and decibels from -10 to +65 db.

Model MM-1 uses standard commercially available batteries and is not affected by strong RF fields as encountered in and near transmitting equipment. 1% precision resistors on a very easily wired ring type range switch and a highly accurate Simpson 50 microampere meter fully qualifies the Heathkit Multimeter for close tolerance laboratory and service work. The meter movement is placed in a recessed position for maximum non-glare readability. The kit includes the attractive black bakelite cabinet, 2 color meter scales, test leads, batteries and all other necessary components. Overall cabinet size is 5 1/2" wide x 4" deep x 7 1/2" high.



MODEL MM-1

\$26⁵⁰

Ship. Wt. 6 lbs.

Heathkit TUBE CHECKER KIT



MODEL TC-2
\$29⁵⁰

Shipping Wt. 12 lbs.

Checks overall tube quality, filament continuity, and individual elements for shorts and opens. Features chart illumination, harness type wiring, and large 3-color meter scale.

Portable Model TC-2P at \$34.50. Wt. 14 lbs. No. 91-8 Cabinet only at \$7.50. Wt. 7 lbs. No. 355 TV Picture Tube Adapter at \$4.50. Wt. 1 lb.

Heathkit LABORATORY GENERATOR KIT



MODEL LG-1
Ship. Wt. **\$39⁵⁰**
16 lbs.

A professional laboratory instrument designed for extreme accuracy in frequency and output level. Colpitts oscillator operates in 5 ranges from 150 KC to 30 MC. Panel meter calibrated in output voltage and percent of modulation. Output in excess of .1 volts. Features complete shielding of oscillator, buffer and attenuator sections; regulated power supply and 50 ohm output cable. Comparable instruments priced many times higher than the cost of this new kit.

Heathkit AUDIO WATTMETER KIT



MODEL AW-1
Ship. Wt. **\$29⁵⁰**
6 lbs.

Measure output power levels directly with the Heathkit Audio Wattmeter. Flat response to frequencies from 10 CPS to 250 KC. Full scale ranges of 5 MW, 50 MW, 500 MW, 5 W and 50 W. Db calibration from -10 to +48. Uses non-inductive built-in load resistors providing impedances of 4, 8, 16 and 600 ohms. Meter bridge uses 4 germanium diodes.

HEATH COMPANY • Benton Harbor 20, Mich.

SERVICEMAN • AMATEUR • STUDENT

Heathkit IMPEDANCE BRIDGE KIT

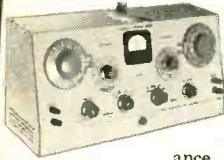

MODEL IB-2
\$59⁵⁰

Ship. Wt. 15 lbs.

Modern design with built-in 1 KC generator for AC measurements. A choice of the Wheatstone, Maxwell, Hay or capacitance comparison bridges for measuring resistance, capacitance, inductance, dissipation factor and storage factor. 1/2% resistors and precision mica condensers provide maximum accuracy. Completely AC operated.

Heathkit DECADE RESISTANCE KIT

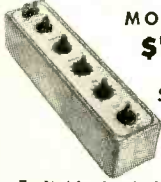

MODEL DR-1
\$19⁵⁰

Ship. Wt.
4 lbs.

Individual switch selection of twenty 1% precision resistors in 1 ohm steps from 1 to 99,999 ohms. Sturdy ceramic wafer switches featuring silver plated contacts and smooth, positive detent action.

Heathkit COMMUNICATIONS RECEIVER KIT



MODEL AR-2
\$25⁵⁰
Ship. Wt. 12 lbs.
(Less Cabinet)

Full coverage from 550 KC to 35 MC on 4 bands, with good sensitivity and selectivity. Features electrical bandspread, BFO, headphone jack, slide rule dial with ham band identification, RF gain control, noise limiter and phone-standby-CW switch. Top quality, high gain components used throughout. Pre-wound coils in a shielded turret assembly and a transformer operated power supply assure trouble-free performance.

Cabinet available separately. No. 91-10. Shipping wt. 5 lbs. Price \$4.50.

Heathkit AUDIO OSCILLATOR KIT

MODEL AO-1
\$24⁵⁰

Ship. Wt.
11 lbs.



Features sine or square wave coverage from 20-20,000 cycles in 3 ranges. Variable 10 volt output level at 600 ohms impedance. Thermistor controlled linearity—precision multiplier resistors—distortion less than .6%. An outstanding instrument value at this amazing low price.

Heathkit Q METER KIT

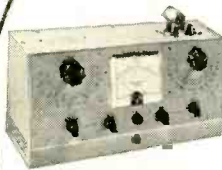

MODEL QM-1
\$44⁵⁰ Ship. Wt. 14 lbs.

A typical Heathkit invasion of the laboratory instrument field. Here is the first successful low priced Q meter ever offered in kit form. Oscillator supplies RF in the range of 150 KC to 18 mc. Reads Q directly on calibrated meter scales. Measures Q of condensers, RF resistance and distributed capacity of coils. Calibrate capacitor with range of 40 mmf to 450 mmf with vernier ±3 mmf. All measurements made at the operating frequency.

Heathkit AMATEUR TRANSMITTER KIT



MODEL AT-1
\$29⁵⁰

Ship. Wt. 16 lbs.

Power input up to 35 watts on 80, 40, 20, 15, 11 and 10 meters. Can be crystal or VFO excited. Complete with modulator input socket and VFO power output provisions. Other desirable features are good shielding, AC line filter, key click filter, standby switch and a 52 ohm coaxial output. Model AT-1 is AC operated and is suitable as an exciter for a higher powered rig. Complete with full instructions for construction and use.

Heathkit TELEVISION SWEEP GENERATOR KIT



MODEL TS-3
\$44⁵⁰

Ship. Wt. 18 lbs.

Simplify your TV alignment jobs with the new Heathkit TS-3. Full coverage on fundamentals from 4 MC to 220 MC at an output of well over 100,000 microvolts. . . Automatic blanking and wide range phasing. A triple marker system ranges from 19 MC to 180 MC using a Colpitts oscillator plus the 4.5 MC crystal controlled oscillator for check points (crystal furnished). Provisions are also made for using an external marker. Featured is the new sweep system, using an *INCREDUCTOR controllable inductor. Sweep width is variable from 0 to 12 MC at the lower RF frequencies and increases to 0-50 MC at the highest. . . Other advantages are power supply regulation, constant RF output level, independent marker and RF output control circuits, low impedance output and properly terminated output cables. The construction manual is complete in all detail and with a reasonable amount of care, Model TS-3 will serve faithfully for many years to come.

*Trademark, C.G.S. Laboratories, Stamford, Connecticut

Heathkit DECADE CONDENSER KIT

Switch selected 1% silver mica precision condensers providing capacity range of 100 mmf. to 0.111 mfd. in steps of 100 mmf.

MODEL DC-1
\$16⁵⁰

Shipping Wt. 4 lbs.



Heathkit AUDIO GENERATOR KIT

A new extended range 18 cycles —1 megacycle audio instrument at a remarkably low price. Five continuously variable output ranges—600 ohm output impedance—low distortion figure, less than .4% from 100 cps through audible range.



MODEL AG-8
\$29⁵⁰

Ship. Wt. 11 lbs.

Heathkit BAR GENERATOR KIT



Small, compact and easy to use. Model BG-1 supplies horizontal or vertical bars for TV linearity adjustments. Output cable clips directly to the TV receiver antenna terminals.

MODEL BG-1

Ship. Wt. 6 lbs. **\$14⁵⁰**

Heathkit BATTERY ELIMINATOR KIT

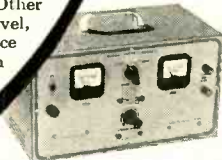

MODEL BE-4
\$31⁵⁰ Ship. Wt. 18 lbs.

6 or 12 volt operation with current and voltage constantly monitored. Double protection with a fused transformer and automatic overload relay. Well filtered output and all heavy duty components. Designed for auto radio repair and as a storage battery charger.

WRITE FOR *Free* CATALOG

New 40 page 1954 Catalog lists all kits, specifications and latest price information.

HEATH COMPANY • Benton Harbor 20, Mich.

SPACE SOUND

*New discovery may
pave the way for
the inertialess
loudspeaker*

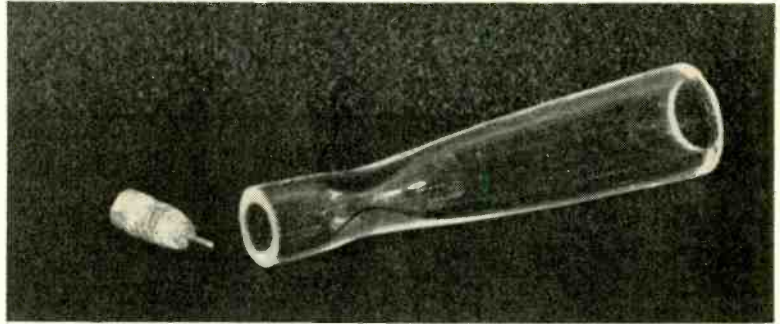

The fundamental Ionophone unit, demonstrated in the U. S. recently.

A RECENT report from France states that audible sounds have been produced in the empty space between two loudspeakers, both of which were operating at an ultrasonic frequency. This accomplishment was reported by Siegfried Klein, inventor of the Ionophone, in a paper published in the January 1954 issue of the *Annales des Telecommunications*. This sound is produced only when the two speakers face each other an integral number of half waves apart. It is strongest in the vicinity of the nodes and loops of the standing-wave pattern between the speakers.

Musicians are familiar with beats between two sound waves of nearly the same frequency, and radiomen know that the superheterodyne receiver

noted only at very low frequencies; presumably when the beat rises far enough in frequency to be heard as a musical sound it is masked by the two louder notes that produce it.)

If two ultrasonic waves beat together at an audible rate, only the beat frequency can be audible. Two Ionophones, operating 2,000 cycles apart, were used to produce the sound-in-space effects.

The Ionophone (RADIO-ELECTRONICS, November and December, 1951) is a true molecular speaker, and works better as the frequency is increased. As illustrated in the photo, it is a small quartz glass exponential horn, approximately 2 inches long. Its larger end is butted smoothly to the small end of a larger horn, which continues the exponential curve to make the unit look like an ordinary tweeter. (This description is of a unit commercially manufactured by the British firm of Plessey as the tweeter of a woofer-tweeter combination.)

The smaller end of the Ionophone is just large enough to admit a fine platinum wire. Radio-frequency energy (at about 27 mc) applied to this wire causes it to ionize the air around it, producing a pink glow in the "throat" of the horn. When the r.f. current is modulated by speech or music, the varying ionization sets up pressures in the air as would a moving diaphragm. These variations in pressure are heard as sound.

As a generator of ultrasonics, the Ionophone approaches the ideal, though probably its results in the sound-from-

space experiment might be reproduced with a magnetostriction transducer or possibly even with one of the new capacitor tweeters, which also become more efficient as they leave the audio range.

How the sound is produced

Two Ionophones are mounted 4 to 6 inches apart, pointing directly at each other. In the first experiments, one was excited at 30,000 cycles (30 kc) and the other at 32 kc. The distance between the speakers is varied slightly to bring them to an integral number of half wavelengths apart. (The adjustment is approximate, may be calculated at 30 or 32 kc or some point between them, and is best made by experiment.) At the correct point, a 2,000-cycle beat note is heard coming from the space between the two loudspeakers.

To prove that the sound is not subjective, a microphone and oscilloscope may be used, as in Fig. 1, to pick up the sound. If one of the signals is modulated, as shown in Fig. 2, the 2,000-cycle output note is modulated correspondingly.

In the experiments, reproduction fell short of perfection. One of the bugs was intrusion of the beat-note "carrier." Further work is being undertaken, in which the speaker frequencies will be above 50 kc and far enough apart in frequency that the beat note will itself be ultrasonic. Then only the modulation will be audible.

At present, work is in the purely experimental stages—much at the point the Ionophone was when first reported in late 1951. Enough has been learned, however, to foreshadow the possible development of an entirely new type of loudspeaker, without moving parts—because of the Ionophone—without cone, horn or enclosure—due to ultrasonics—and possibly with a new method of reproducing bass notes by frequency-modulating one of the waves so that the wavelength (and therefore the amplitude of the standing-wave pattern and the sound produced by that pattern) is varied accordingly.

END

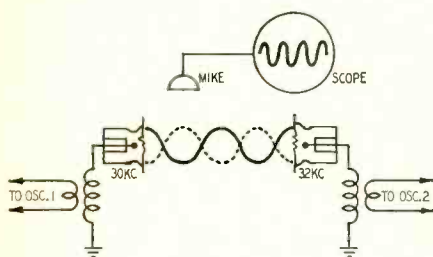

Fig. 1—Microphone and scope are used to explore area where sound is produced.

works because of similar beats between two r.f. waves. As in the radio circuit, the sound beats occur at a rate equal to the frequency difference between the two waves. (These beats have been

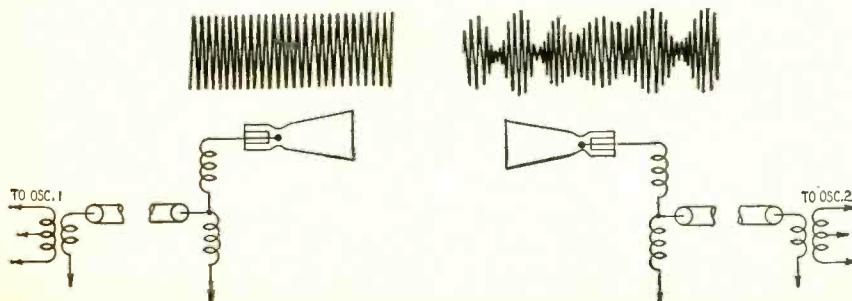

Fig. 2—Experimental setup for modulation with speech and music frequencies.

SOUND DESTROYS SOUND

A noise-reducing system which amplifies the sound and uses it to oppose and cancel the original noise

THE April, 1952, issue of RADIO-ELECTRONICS carried an article about a strange apparatus which was supposed to neutralize noise by picking it up with a microphone, amplifying it, and reproducing it at the original loudness, but 180 degrees out of phase. The original sound and that produced by the speaker would then annihilate each other. That article was not meant to be taken seriously—it was in fact our annual April Fool story. But many people *did* take it seriously, and many requests for more information were received. Apparently there is a big need for just such a noise neutralizer.

Prospective users were not the only ones interested in noise neutralization. Such minds as Dr. Harry F. Olson of RCA, possibly the country's foremost acoustical authority, were also working on it. The reason is that the stand-

ard method of absorbing sound in some porous material becomes progressively less efficient as the frequency is lowered. For example, in the well-padded interior of an airplane high-frequency noises are practically absent, and conversation sounds as it would in a sound-conditioned room. But the low-frequency roar of the engine comes through with near-maddening intensity. Looking for a way to reduce low-frequency noise, RCA scientists turned to resonators and out-of-phase sound waves for a solution.

Cancellation of out-of-phase sound

waves is not a new idea. For many years high-school students have experimented with the setup of Fig. 1. The two large-mouthed bottles are so "tuned" by glass slides placed across their mouths as to resonate loudly with the tuning fork. Correct tuning and positioning of the jars then results in a great reduction of sound as the waves from the bottles cancel each other.

Why not, then, use simple resonators as sound absorbers? They do work, but they have serious disadvantages. At the low frequencies where they are needed, they would be very bulky. And they are rather sharply tuned. A battery of 20 such resonators with a total content of 40 cubic feet would be needed to cover the range from 30 to 200 cycles, according to Dr. Olson.

The electronic sound absorber can be made to act like a whole group of individual resonators, absorbing sound over a wide band in the lower frequencies. It consists of a microphone, amplifier, and speaker, arranged as in Fig. 2. The phasing of the signal is so controlled that the output of the speaker acts to reduce the sound pressure around the area of the microphone.

The equipment has to meet some rather particular specifications. The speaker, for example, is only 3 inches in diameter (to keep the enclosure size down) yet has a natural resonance of 30 cycles (to work most effectively at low frequencies). The soundproof enclosure is dictated by the fact that no sound can be permitted to come from the back of the speaker. The microphone is a special electronic type chosen for low-frequency response and phase characteristics. (RCA Radiotron 5734, described in this magazine July, 1948, page 36).

The microphone is oriented in the

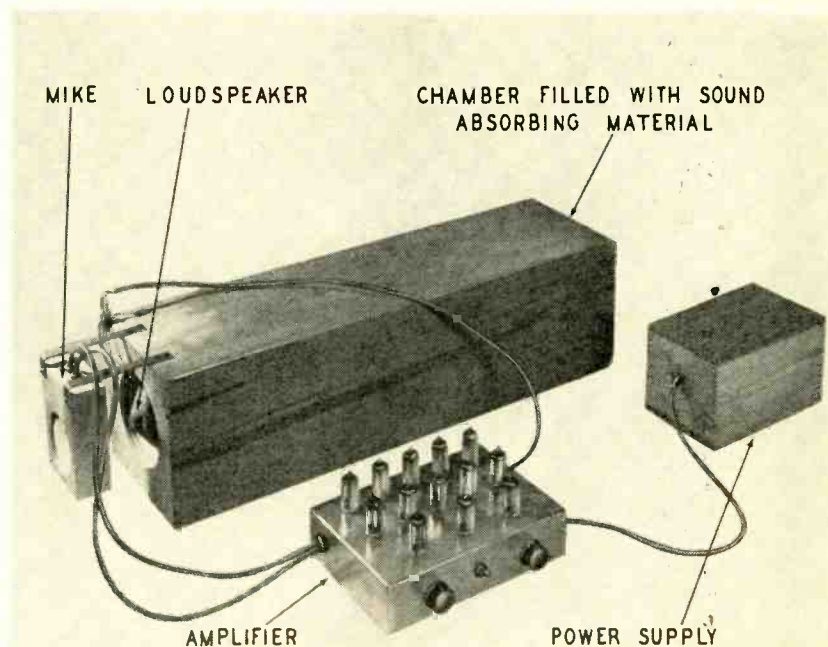
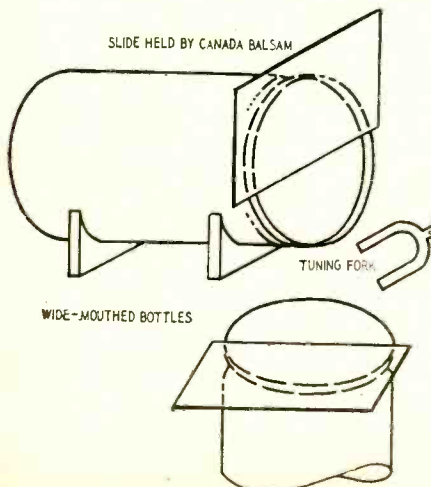

Fig. 1—Setup for sound cancellation. The absorber includes three units: microphone, speaker-enclosure and amplifier.

AUDIO—HIGH FIDELITY

direction of the sound to be suppressed, and shielded from sound from its own speaker. The complete enclosure—less than half a cubic foot in bulk—can then be used to reduce noise over a small or larger area.

For spot noise reduction, the equipment is placed in the center of the spot

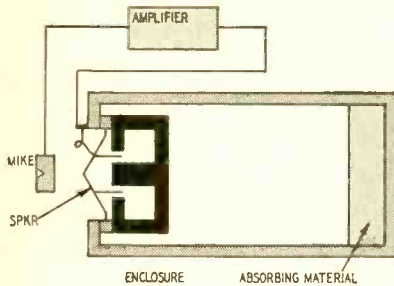

Fig. 2—The electronic sound absorber.

of desired low noise level. It is suggested, for example, that it could be placed in or on the back of an airplane seat, reducing the sound level 10 to 20 decibels. A sound absorber might also be mounted near the head of the operator of a noisy machine, putting the

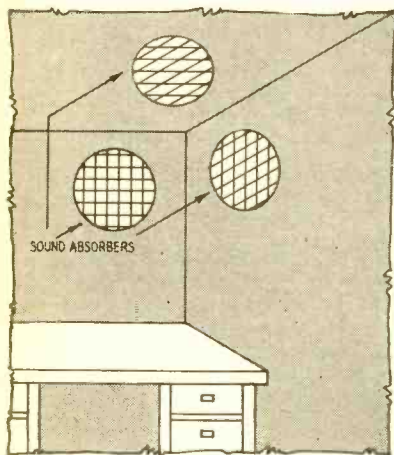

Fig. 3—Reducing sound in room corner.

operator's ears in a region of lower noise. Since many machine operations are such that the operator's head normally remains in the same small area most of the time, the noise he hears could be reduced tremendously in many cases.

To reduce the noise level over a wider area, a bank of absorbers may be used, much in the manner of ordinary sound-absorbing material. Fig. 3 shows three mounted around the corner of a room or office.

Another application of the large-area absorber is to mount a bank of units near the point the noise is produced. Thus noise neutralizers could be used to reduce sound intensity around large internal-combustion engine exhausts, air conditioner ducts and similar sources of loud low-frequency noise. **END**

Announcing—

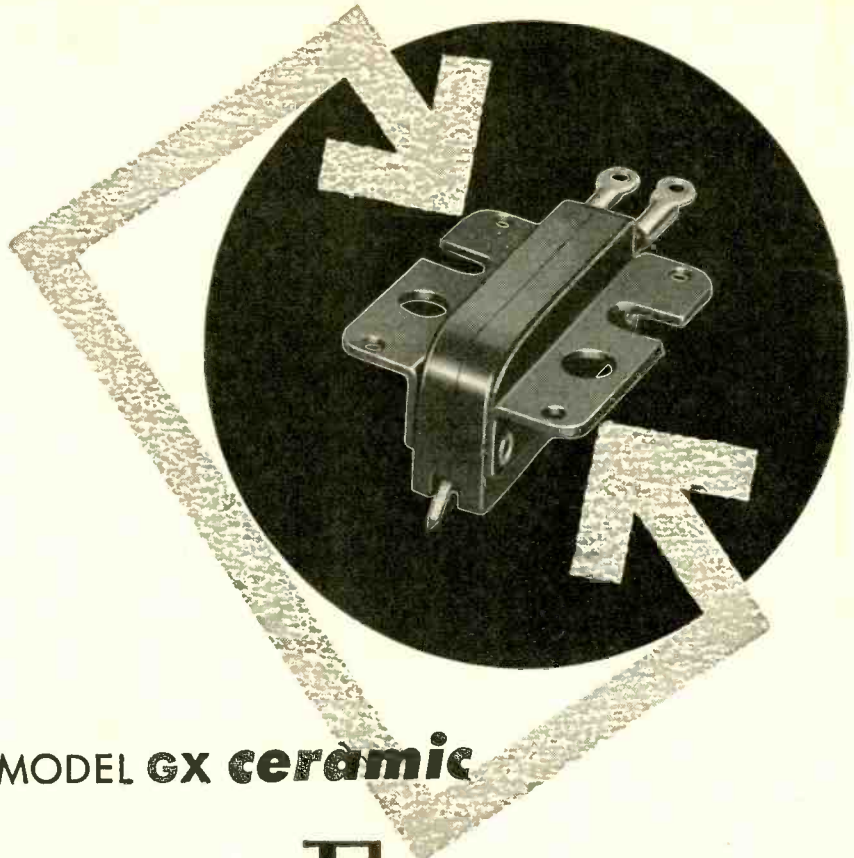

MODEL GX ceramic

WEBSTER ELECTRIC
Featheride[®]

REPLACEMENT CARTRIDGE
for 33 $\frac{1}{3}$ and 45 rpm use

• Here is WEBSTER ELECTRIC's answer to the wide demand for a high quality, small-sized, durable **ceramic** replacement cartridge. The new Model GX defies any weather and climate—its ceramic construction enables it to withstand extremes of temperature and humidity.

It is designed especially for fast on-the-spot replacement in any standard RMA $\frac{1}{2}$ " mounting, such as the Columbia 33 $\frac{1}{3}$ —also in all RCA 45 record players ($\frac{1}{2}$ " to $\frac{5}{8}$ " mounting).

Stock and sell this new **ceramic** member of the famous Featheride family for added sales and profits. Write today for full information.

DATA ON THE MODEL GX

TYPE • Single-needle ceramic cartridge for 33 $\frac{1}{3}$ and 45 rpm use

OUTPUT • Develops 0.6 volt at 33 $\frac{1}{3}$ rpm ... 0.8 volt at 45 rpm

TRACKING PRESSURE 7.0 gr.

CUTOFF FREQUENCY 10,000 C.P.S.

NET WEIGHT • 5.0 gr.

NEEDLE • Single 1-mil Osmium

WEBSTER
RACINE



ELECTRIC
WISCONSIN

"Where Quality Is a Responsibility and Fair Dealing an Obligation"
WEBSTER ELECTRIC COMPANY, RACINE, WISCONSIN • EST. 1909

AUDIO—HIGH FIDELITY

versus frequency for a small, constant-input voltage, showing that the low-level power output is constant to within 3 db from 25 to 15,000 c.p.s. The square-

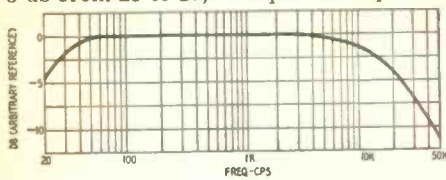

Fig. 2—Output versus frequency curve.

wave response of the amplifier is smooth and well-damped, displaying no ringing or overshoot. There is also no tendency toward transient oscillation when the amplifier is overdriven. Fig. 3 is the power output in decibels above 1 watt for 1% total harmonic distortion.

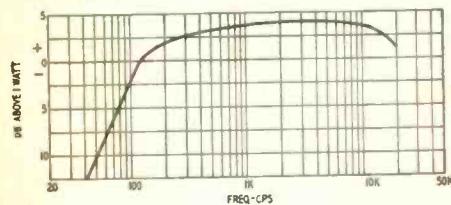

Fig. 3—Amplifier output in db above 1 watt for 1% total harmonic distortion.

Curve A in Fig. 4 shows the total harmonic distortion in percent for 1 watt power output. At this power level, the harmonic distortion is less than 2% for all audio frequencies above 70 c.p.s. Curve B is the harmonic distortion for 2 watts output. Fig. 5 is a

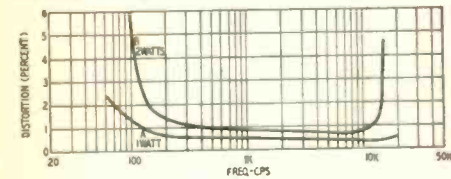

Fig. 4—Curves of total harmonic distortion for 1 and 2 watts power output.

plot of amplifier output impedance versus frequency. At low frequencies, where loudspeaker damping is important, the output impedance is slightly greater than 1 ohm. At 1,000

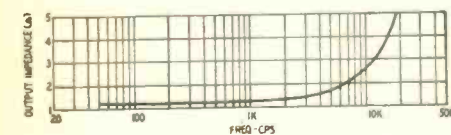

Fig. 5—Output impedance is below 2 ohms for frequencies below 7,000 cycles.

Materials for low-cost amplifier

Resistors: 1—40 ohms, 10 watts, 1—150, 1—33,000, 1—100,000 ohms, 1 watt; 2—2,200, 1—4,700, 4—220,000 ohms, 1/2 watt; 1—100,000, 1—250,000 ohms, potentiometer with audio taper.

Capacitors: (Paper) 1—0.1, 1—1.0 μ f, 200 volts or more; 2—.05 μ f, 400 volts. (Electrolytic) 2—10, 1—40 μ f, 150 volts; 1—40 μ f, 250 volts.

Miscellaneous: 1—Audio-output transformer, 3,500-ohm primary, 3.5-ohm secondary, 8 watts (Merit A-3018 or equivalent); 1—s.p.s.t. switch; 2—octal sockets, 1—9-pin miniature socket with shield; chassis, hookup wire, line cord, hardware.

c.p.s. and full gain, the amplifier delivers 2 watts to a 4.7-ohm load with an r.m.s. input of 120 millivolts. END

across the spectrum...

it's TACO that gets 'em!

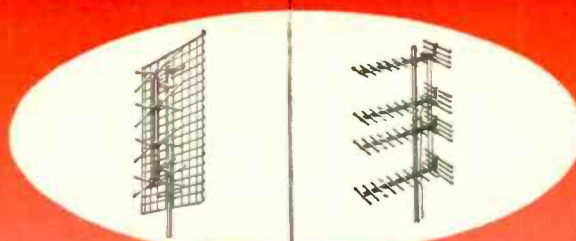

CAT. NO. 3006C Four-stacked bow-tie—Receives all UHF channels. Exceptional gain. Fine directivity. Available in many models from single bow-tie to array of 12.

CAT. NO. 3015 Grid yagi—Finest UHF antenna made. Available as single, double or four-stacked array. Excellent front-to-back ratio.

83

UHF

14

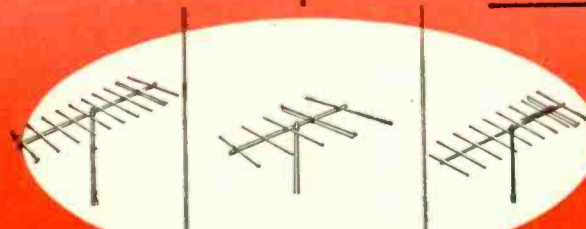

CAT. NO. 1830 Silver Streak High-band—Optimum gain and signal-to-noise ratio on any single high-band VHF channel. Recommended for weakest signal areas.

CAT. NO. 1350 3-element yagi high-band—The best buy among medium price antennas. Provides excellent gain and directivity on any single high band channel.

CAT. NO. 1860 Bazooka-Tuned high-band—Provides yagi gain and directivity throughout entire VHF high band. Bazooka element assures perfect impedance match on all channels.

13

VHF

7

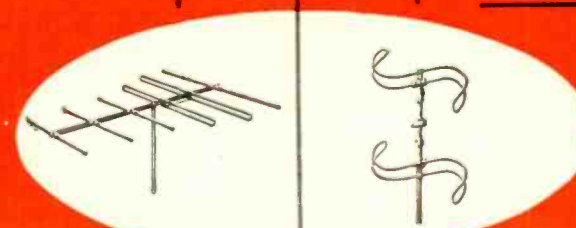

CAT. NO. 644 Twin-driven FM—Ideal for fringe areas. Receives entire UHF band with highest signal-to-noise ratio. Sharp directivity. Single or stacked.

CAT. NO. 6245T Omni-directional—Perfect circular gain pattern. Receives FM from all directions without mechanical rotating. Single or stacked.

FM

6

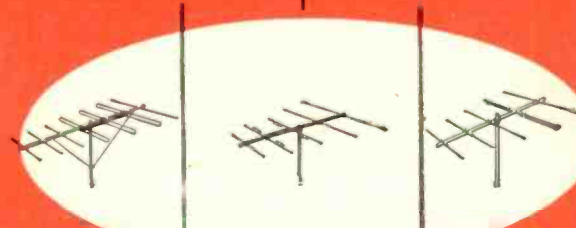

CAT. NO. 1840 Triple-driven yagi—Single channel yagi characteristics throughout the low-band. Provides maximum signal pickup and gain.

CAT. NO. 1880 Broad band Trapper—The most revolutionary TV antenna ever offered. Peak performance on channels 2 through 13. Also UHF in prime service areas.

CAT. NO. 1325 3-element yagi—For those installations where price is a "must." Yagi gain and characteristics in a medium priced antenna.

VHF

2

FOR COMPLETE INFORMATION ON THESE AND OTHER TACO ANTENNAS, ASK FOR YOUR COPY OF THE TACO LOCALIZED CATALOG...

TECHNICAL APPLIANCE CORPORATION, SHERBURNE, N. Y.

In Canada: Hackbusch Electronics Ltd., Toronto 4, Ont.



Measures 6 1/4" x 9 1/2" x 4 1/2"

Superior's new
Model 670-A

SUPER METER

A COMBINATION VOLT-OHM MILLIAMMETER PLUS
CAPACITY REACTANCE INDUCTANCE AND DECIBEL MEASUREMENTS

SPECIFICATIONS:

D.C. VOLTS: 0 to 7.5/15/75/150/750/1,500/7,500 Volts
A.C. VOLTS: 0 to 15/30/150/300/1,500/3,000 Volts
OUTPUT VOLTS: 0 to 15/30/150/300/1,500/3,000 Volts
D.C. CURRENT: 0 to 1.5/15/150 Ma. 0 to 1.5/15 Amperes
RESISTANCE: 0 to 1,000/100,000 Ohms 0 to 10 Megohms
CAPACITY: .001 to 1 Mfd. 1 to 50 Mfd. (Quality test for electrolytics)
REACTANCE: 50 to 2,500 Ohms 2,500 Ohms to 2.5 Megohms
INDUCTANCE: .15 to 7 Henries 7 to 7,000 Henries
DECIBELS: -6 to +18 +14 to +38 +34 to +58

ADDED FEATURE:

The Model 670-A includes a special **GOOD-BAD** scale for checking the quality of electrolytic condensers at a test potential of 150 Volts.

The Model 670-A comes housed, in a rugged crackle-finished steel cabinet complete with test leads and operating instructions.

\$28⁴⁰
NET



Superior's new
Model TV-11

TUBE TESTER

SPECIFICATIONS:

- ★ Tests all tubes including 4, 5, 6, 7, Octal, Lock-in, Peanut, Bantam, Hearing Aid, Thyatron Miniatures, Sub-miniatures, Novals, Sub-minars, Proximity fuse types, etc.
- ★ Uses the new self-cleaning Lever Action Switches for individual element testing. Because all elements are numbered according to pin-number in the RMA base numbering system, the user can instantly identify which element is under test. Tubes having tapped filaments and tubes with filaments terminating in more than one pin are truly tested with the Model TV-11 as any of the pins may be placed in the neutral position when necessary.
- ★ The Model TV-11 does not use any combination type sockets. Instead individual sockets are used for each type of tube. Thus it is impossible

to damage a tube by inserting it in the wrong socket.

- ★ Free-moving built-in roll chart provides complete data for all tubes.
- ★ Newly designed Line Voltage Control compensates for variation of any Line Voltage between 105 Volts and 130 Volts.
- ★ **NOISE TEST:** Phono-jack on front panel for plugging in either phones or external amplifier will detect microphonic tubes or noise due to faulty elements and loose internal connections.

The model TV-11 operates on 105-130 Volt 60 Cycles A.C. Comes housed in a beautiful hand-rubbed oak cabinet complete with portable cover

\$47⁵⁰
NET

EXTRA SERVICE—The Model TV-11 may be used as an extremely sensitive Condenser Leakage Checker. A relaxation

type oscillator incorporated in this model will detect leakages even when the frequency is one per minute.

SUPERIOR'S NEW MODEL TV-40

C.R.T. TUBE TESTER

A complete picture tube tester
★ for little more than the price of a "make-shift" adapter!!

★ Tests all magnetically deflected tubes . . . in the set . . . out of the set . . . in the carton!!

The Model TV-40 is absolutely complete! Self-contained, including built-in power supply. It tests picture tubes in the only practical way to efficiently test such tubes; that is by the use of a separate instrument which is designed exclusively to test the ever increasing number of picture tubes!

EASY TO USE:

Simply insert line cord into any 110 volt A.C. outlet, then attach tester socket to tube base (Ion Trap Need Not Be on Tube). Throw switch up for quality test . . . read direct on Good-Bad scale. Throw switch down for all leakage tests.

SPECIFICATIONS:

- Tests ALL magnetically deflected picture tubes from 7 inch to 30 inch types.
- Tests for quality by the well established emission method. All readings on "Good-Bad" scale.
- Tests for inter-element shorts and leakages up to 5 megohms.
- Test for open elements.

Model TV-40 C.R.T. Tube Tester comes absolutely complete—nothing else to buy. Housed in round cornered, molded bakelite case. Only

\$15⁸⁵
NET



**SHIPPED ON APPROVAL
NO MONEY WITH ORDER — NO C. O. D.**

Try any one of the above instruments for 10 days before you buy. If completely satisfied then send down payment and pay balance as indicated on coupon. No Interest or Carrying Charges Added! If not completely satisfied return unit to us, no explanation necessary.

MOSS ELECTRONIC DISTRIBUTING CO., INC.
Dept. D-53, 3849 Tenth Ave., New York 34, N. Y.

Please send me the units checked. I agree to pay down payment within 10 days and to pay the monthly balance as shown. It is understood there will be no carrying, interest or any other charges, provided I send my monthly payments when due. It is further understood that should I fail to make payment when due, the full unpaid balance shall become immediately due and payable.

Model 670-A Total Price \$28.40
\$7.40 within 10 days. Balance \$3.50
monthly for 6 months.

Model TV-11 Total Price \$47.50
\$11.50 within 10 days. Balance \$6.00
monthly for 6 months.

Model TV-40 Total Price \$15.85
\$3.85 within 10 days. Balance \$4.00
monthly for 3 months.

Name _____
Address _____
City _____ Zone _____ State _____



Superior's New Model 770-A

The FIRST Pocket-Sized

VOLT-OHM MILLIAMMETER USING THE NEW "FULL-VIEW" METER

71% MORE SCALE AREA!!

Yes, although our new FULL-VIEW D'Arsonval type meter occupies exactly the same space used by the older standard 2 1/2" Meters, it provides 71% more scale area. As a result, all calibrations are printed in large easy-to-read type and for the first time it is now possible to obtain measurements instead of approximations on a popular priced pocket-sized V.O.M.

THE MODEL 770-A COMES COMPLETE WITH SELF-CONTAINED BATTERIES, TEST LEADS AND ALL OPERATING INSTRUCTIONS. ONLY

Features

- ★ Compact — measures 3 1/8" x 5 7/8" x 2 1/4"
- ★ Uses "Full View" 2% accurate, 850 Microampere D'Arsonval type meter
- ★ Housed in round-cornered, molded case
- ★ Beautiful black etched panel. Depressed letters filled with permanent white, insures long-life even with constant use.

Specifications

6 A.C. VOLTAGE RANGES: 0-15/30/-150/300/1500/3000 Volts. 6 D.C. VOLTAGE RANGES: 0-7.5/15/75/150/-750/1500 Volts. 2 RESISTANCE RANGES: 0-10,000 Ohms, 0-1 Megohm. 3 D.C. CURRENT RANGES: 0-15/150 Ma., 0-1.5 Amps. 3 DECIBEL RANGES: -6 db to +18 db, +14 db to +38 db, +34 db to +58 db.

\$15⁸⁵ NET

Superior's
New

TELEVISION BAR GENERATOR

THROWS AN ACTUAL BAR PATTERN ON ANY TV RECEIVER SCREEN



Two Simple Steps

1. Connect Bar Generator to Antenna Post of any TV Receiver.
2. Plug Line Cord into AC Outlet and Throw Switch.

Result: A stable never-shifting vertical or horizontal pattern projected on the screen of the TV receiver under test.

SPECIFICATIONS:

Power Supply: 105-125 Volt 60 Cycles
Power Consumption: 20 Watts
Channels: 2-5 on panel, 7-13 by harmonics
Horizontal lines: 4 to 12 (Variable)
Vertical lines: 12 (Fixed)
Vertical sweep output: 60 Cycles
Horizontal sweep output: 15,750 Cycles

FEATURES:

Provides linear pattern to adjust VERTICAL linearity, height, centering • Provides linear pattern to adjust HORIZONTAL drive, width, peaking, linearity, centering • Provides vertical sweep signal for adjusting and synchronizing vertical oscillator discharge and output tubes • Provides vertical signal to replace vertical oscillator to check vertical amplifier operation • Provides horizontal sweep signal for adjusting and synchronizing horizontal oscillator A.F.C. and output tubes • Provides horizontal sweep signal to check H.V. section of fly-back and pulse operating power supplies • Provides signal for testing video amplifiers • Can be used when no stations are on the air.

TV BAR GENERATOR COMES COMPLETE WITH SHIELDED LEADS AND DETAILED OPERATING INSTRUCTIONS. ONLY.....

\$39⁹⁵ NET



Superior's New Model 660-A AN AC OPERATED

SIGNAL GENERATOR

PROVIDES COMPLETE COVERAGE for AM-FM & TV Alignment

SPECIFICATIONS:

- Generates Radio Frequencies from 100 Kilocycles to 60 Megacycles on fundamentals and from 60 Megacycles to 220 Megacycles on powerful harmonics. • Accuracy and Stability are assured by the use of permeability trimmed Hi-Q coils. • R.F. available separately or modulated by the internal audio oscillator. — Built in 400 cycle sine wave audio oscillator used to modulate the R.F. signal also available separately for audio testing of receivers, amplifiers, hard of hearing aids, etc.
- R.F. Oscillator Circuit: A high transconductance

heptode is used as an R.F. oscillator, mixer and amplifier. Modulation is effected by electron coupling in the mixer section thus isolating the oscillator from load changes and affording high stability. • A.F. Oscillator Circuit: A high transconductance heptode connected as a high- μ triode is used as an audio oscillator in a High-C Colpitts Circuit. The output (over 1 Volt) is nearly pure sine wave. • Attenuator: A 5 step ladder type of attenuator is used.

TUBES USED:

- 1-6BE6 as R.F. Oscillator, mixer and amplifier.
- 1-6BE6 as Audio Oscillator.
- 1-6H6 as Power Rectifier.

The Model 660-A comes complete with coaxial cable test lead and instructions.

\$42⁹⁵ NET

**SHIPPED ON APPROVAL
NO MONEY WITH ORDER — NO C. O. D.**

Try any of the above instruments for 10 days before you buy. If completely satisfied then send down payment and pay balance as indicated on coupon. No Interest or Carrying Charges Added! If not completely satisfied return unit to us, no explanation necessary.

MOSS ELECTRONIC DISTRIBUTING CO., INC.
Dept. D-53, 3849 Tenth Ave., New York 34, N. Y.

Please send me the units checked. I agree to pay down payment within 10 days and to pay the monthly balance as shown. It is understood there will be no carrying, interest or any other charges, provided I send my monthly payments when due. It is further understood that should I fail to make payment when due, the full unpaid balance shall become immediately due and payable.

Model 660-A.....Total Price \$42.95
\$12.95 within 10 days. Balance \$5.00
monthly for 6 months.

Model 770-A.....Total Price \$15.85
\$3.85 within 10 days. Balance \$4.00
monthly for 3 months.

Television Bar Generator Total Price \$39.95
\$9.95 within 10 days. Balance \$5.00
monthly for 6 months.

Name

Address

City..... Zone..... State.....

Solar Battery Powers Transmitter

By D. M. CHAPIN* and D. E. THOMAS

This sun-powered battery and a tiny FM unit make a complete pocket-size self-powered radiophone

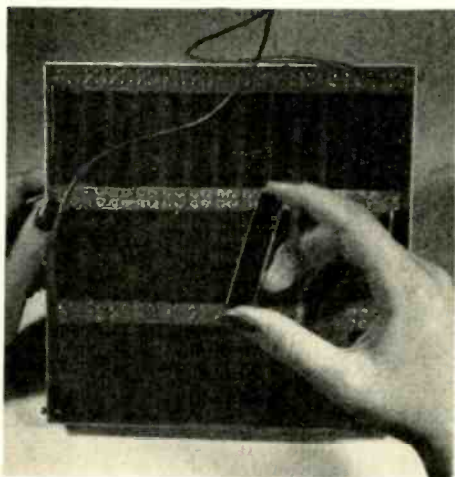

Fig. 1—A 39-cell solar battery.

THE Bell solar battery and the FM transistor transmitter shown on the front cover together constitute a solar powered radio transmitting station which uses the sun's energy to transmit speech or music. The solar battery, recently invented at Bell Telephone Laboratories, converts the sun's radiation directly into usable amounts of electrical power; no other power source is needed by the transmitter. This article will explain how this is done.

Everyone knows that the sun delivers large amounts of energy as heat. It is not so generally recognized that all this heat comes as radiation. Even that part which we can't see and are accustomed to calling heat rays differs from the light or visible portion only in "color" or wavelength. To obtain electrical power by first converting this radiation into heat, as in a sun-powered thermocouple or steam engine, is very inefficient, especially in low power units. The solar battery

*Co-inventor, with G. L. Pearson and C. S. Fuller, of the Bell solar battery.

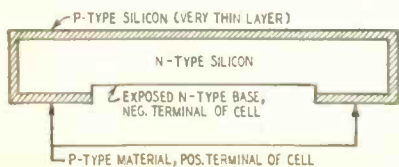

Fig. 2—Cross-section of silicon cell.

uses radiation directly without conversion to heat.

Before looking further into the actual operation of a solar battery, perhaps we should first consider the nature of the battery itself. One form is shown in the photograph, Fig. 1. It is made up of strips of silicon approximately 1/25 inch thick, 1/2 inch wide, and about 2 inches long. Each strip is a photovoltaic cell. The whole top surface is sensitive to visible light and infra-red radiation. Mounted together to present a large surface to the sun, they convert useful amounts of radiation to electrical power.

As might be expected, the size and shape of a solar cell are determined largely by the properties of silicon and the manner of use. When the action of light on silicon is understood, the main features of construction become understandable.

Two types of silicon are used. When very small quantities of certain impurities are added to pure silicon, the product is called "n," or "negative" type. Certain other impurities produce "p," or "positive" type. When the two types appear side by side in the same piece of silicon, the dividing face is called a p-n junction or barrier and special properties exist here. For our purpose, the important property is the response to light. Light striking the silicon near this barrier liberates positive and negative carriers which cause the p-type region to charge up positive

and the n-type region to charge up negative.

This remarkable property of light and a p-n junction means that current can be drawn from such a cell just as from any voltaic cell. It is required only that we direct enough light to the barrier to be useful and then make good contacts to the p and n regions to obtain the generated current for our use.

The first problem is to get useful amounts of light to the barrier. As might be suspected, light penetrates silicon only a very short distance. It is necessary to spread out the p-n junction over a wide area and have it practically on the surface where the light can get to it. The diffusion process does this. Diffusion at high temperature is used to introduce an impurity of the proper type into a piece of silicon previously prepared with an impurity of a different type. The new impurity resides in a layer only about one ten-thousandth of an inch thick and covering the entire strip to produce a large sensitive surface capable of receiving the sun's radiation and converting it directly into electrical power. Adequate connections must then be made to get out the available current.

The cell's construction

The diagrammatic illustration of a solar cell in Fig. 2 shows how this is done. Contacts are made to the diffused

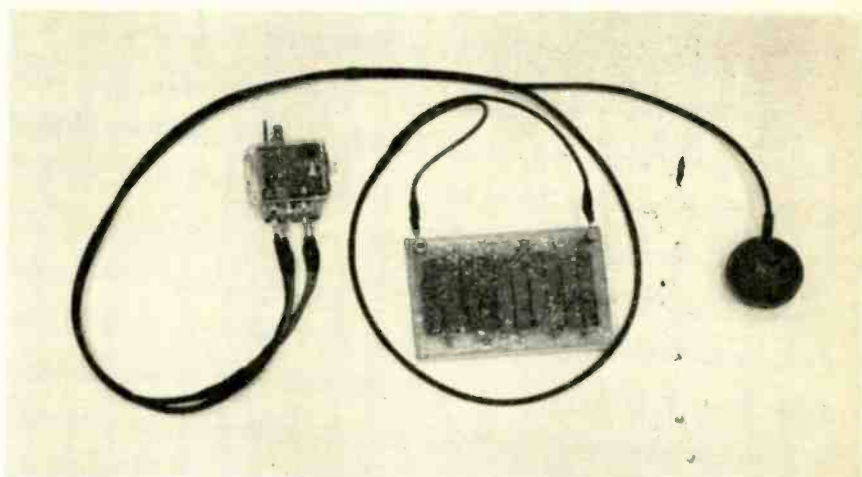

Fig. 3—A mobile station—the solar battery microphone and FM transmitter.

surface layer at the edges of the back or under surface. This leaves the top surface free and unobstructed to catch radiation. The current flows to the edges through the surface layer which has high resistance owing to its thinness. To keep this resistance down to a tolerable level, the strips are made only about half an inch wide. As also shown in the diagram, the surface layer is removed down the middle of the back face to expose the base material. A lead to this base material completes the cell. For the cells shown in the photographs, the outside leads are plus and the center lead is negative.

A silicon cell in full sunlight will produce about half a volt on open

sky even when the sun is hidden from view—as many a sunburned bather will testify. On open circuit or into a high-impedance load, a good voltage appears with much less than full light intensity. For this reason and because the radio transmitter is a high-impedance load, the solar battery and transmitter combination has operated satisfactorily on quite cloudy days.

The transmitter

A closer-up photograph of the solar-powered FM transmitter on the cover appears—in its portable form—in Fig. 3, at the head of this article. This transmitter takes advantage of the small amount of power required by the

the audio amplifier is resistance-capacitance coupled to the input of the oscillator modulator by the resistances R4 and R6 and the capacitance C2.

How it oscillates

Examination of the oscillator modulator circuit shows no apparent source of the coupling required to produce and maintain oscillations and no visible means of producing frequency modulation. The coupling required for oscillation is provided by the parasitic emitter-to-collector capacitance of the transistor, its socket, and external connections. Since in-phase coupling is required to produce CW oscillations, it would appear that coupling through a capacitor with its approximately 90-degree phase shift would not be satisfactory.

The reason the phase of the coupling is correct and also the means by which frequency modulation is obtained is understood when the behavior of the current gain of the transistor is examined as a function of frequency. The magnitude of the current gain of a transistor is not constant with frequency. It begins to decrease as frequency is increased toward and beyond a certain critical point called the cutoff frequency. Accompanying this decrease in current gain, there is a corresponding phase shift in the current gain of the transistor. The transistor oscillates at a frequency well above its critical cutoff frequency where this phase shift is the right order of magnitude to compensate for the phase shift in the emitter-to-collector coupling capacitance. Although the value of the emitter-to-collector capacitance is not critical it is possible to make it too large for oscillation in the v.h.f. region. It is therefore important to keep the oscillator circuit assembly and wiring compact and not increase this capacitance by long emitter and collector leads.

The tank coil L5 is not critical. A half-dozen turns of No. 22 copper wire wound on a 3/8-inch diameter mandrel at about 10 turns to the inch is satisfactory. This coil is then tuned to the desired oscillating frequency with tank capacitor C5. The parasitic capacitances of the transistor also contribute to the tank circuit capacitance. In addition the oscillator oscillates slightly off the exact tank circuit resonant frequency. The tank circuit frequency is therefore adjusted only approximately in the initial assembly and is tuned to the proper frequency when the circuit is actually oscillating. An adjustable trimming capacitor is included as part of C5 to obtain a total range of frequency oscillation of about 10 megacycles.

The FM system

Frequency modulation is obtained because the cutoff frequency of the transistor is not constant with operating point but shifts when the operating point of the transistor is changed.

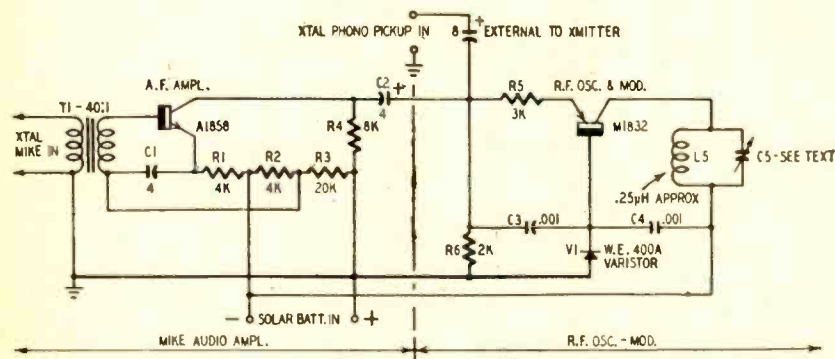

Fig. 4—Schematic of the transistor-operated FM radiophone transmitter.

circuit. Into a load adjusted to take maximum power, the voltage is about one-third volt for a wide range of light intensity. The amount of current available depends on the light intensity and the active area per cell. On short-circuit and in full sunlight, a cell will deliver about one-eighth ampere for each square inch of active surface, or about one-tenth ampere at one-third volt. Groups of cells can be connected in series or parallel depending on whether more voltage or more current is needed. For the FM radio transmitter described here, ten cells were connected in series. Twelve cells would appear to be better except that this transmitter draws so little current that each cell is able to operate at more than the one-third volt indicated for maximum power.

Several mounting techniques have been used. An array of cells held in a metal shell with a transparent cover is shown in Fig. 1. In this case the cells are connected with pressure contacts on the back side. The battery shown on the front cover was cast in solid plastic. This gives a very rugged mounting favored for its durability and apparent resistance to weathering and vibration. In a portable outdoor piece of equipment like a solar transmitter, these are important considerations.

It is not necessary to have full sunlight to get usable amounts of power. Considerable radiation comes from the

transistor, also a Bell Laboratories invention. The transmitter uses a single M1832 point-contact transistor which functions simultaneously as a 106-megacycle r.f. oscillator and frequency modulator, plus an A1858 junction transistor as an audio amplifier. The complete transmitter circuit is packaged in a plastic container about two-thirds the size of a package of cigarettes.

A schematic diagram of the transmitter is shown in Fig. 4. The audio amplifier is needed only when the crystal microphone is used with the crystal phonograph pickup with a suitable step-down transformer will modulate the transistor oscillator directly. The audio amplifier uses an A1858 junction transistor in a grounded-emitter circuit to take advantage of the high audio current gain available with this type connection. The d.c. operating point of the junction transistor is stabilized by R1 in the emitter circuit and the fixed potentiometer made up by resistances R2 and R3 across the solar battery terminals. This potentiometer is adjusted so that the IR drop across R2 is equal to the product of the emitter resistance R1 and the approximate collector current desired—in this case 250 microamperes. C1 is an audio bypass capacitor. A high ratio step-down transformer T1 is used to match the high-impedance crystal microphone to the low-impedance transistor input. The output of

BUY DIRECT . . . and SAVE!

'PRE-FAB' **COLLINS** TUNERS

AUDIO PRODUCTS CO.

High Fidelity TUNERS and TUNER KITS

introducing the LATEST DESIGN

COLLINS CHROMATIC TUNER

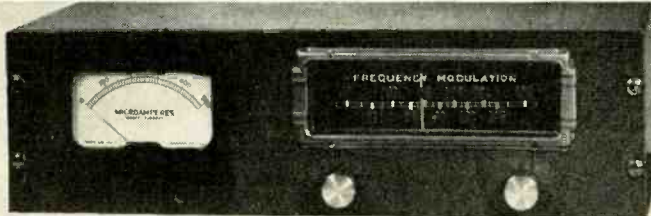

CHECK THESE OUTSTANDING FEATURES

- 4 1/2" tuning meter. Each tuner calibrated in microvolts for direct reading of signal strength.
 - Not a kit. Completely wired, ready to use with FM antenna and amplifier.
 - Sensitivity 3 microvolts with 20 DB of quieting.
 - A.F.C. with disabling switch.
 - New, compact, low design. Only 5 1/4" high. Matches latest bookshelf amplifiers.
 - Voltage regulator tube for added stability.
 - Newly designed front-end using 6BQ7 tube.
 - Dual simultaneous audio output—high and low impedance.
 - Ultra wide range response, 20 to 25,000 cycles.
 - Distortion less than 3/4 of 1%. Hum 50 DB below program.
 - Beautiful golden brown metal cabinet completely enclosing tuner.
 - 5 1/4" x 19" relay rack panel integral part of cabinet.
 - Twelve tubes.
 - Tone compensated volume control.
- Plus many other smaller features which make this tuner the hottest item since high fidelity!

Overall size: 19" W. x 5 1/4" H. x 8 1/2" D. **\$9750**

Shipping weight: 15 lbs.

COLLINS PRE-FAB KITS ALSO AVAILABLE

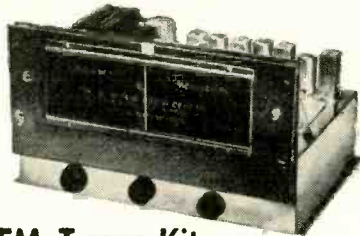

FM Tuner Kit

Shipping weight: 14 lbs. **\$55** with AFC **\$58.50**

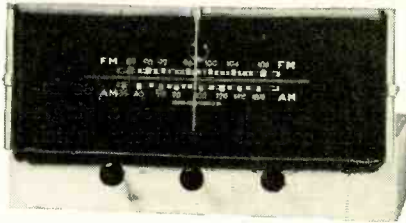

FM/AM Tuner Kit

Shipping Weight 19 lbs. **\$7750** with AFC **\$81**

IF-6 Amplifier . . . 6 tubes Shipping Weight 3 lbs. **\$1975**

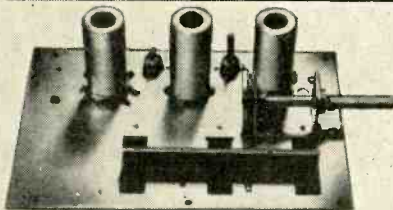

FMF-3 Tuning Unit

Shipping weight: 2 1/2 lbs. **\$1525** with AFC **\$18.75**



AM-4 Tuning Unit

\$2450 Shipping weight: 2 1/2 lbs.

For Users of Collins Tuners:
Receive \$5.00 credit toward the new FMF-3A front end! Mail us your old front end with \$13.75 and we will send you the new, improved FMF-3A with AFC or, remit the full amount of \$18.75 and when we receive your old unit in return a check will be mailed you for \$5.00.

Collins Audio Products Co. is in no way affiliated with Collins Radio Co.

To: Collins Audio Products Co. Inc.
P.O. Box 368, Westfield, N. J. Dept. RE8
Tel. Westfield 2-4390

- Chromatic Tuner FM Tuner Kit FM/AM Tuner Kit
 with AFC with AFC with AFC
 IF-6 Amplifier AM-4 Tuning Unit FMF-3 Tun. Unit
 with AFC

Name _____
Address _____
City _____ State _____

Amount for Kit \$ See weights, add shipping cost \$
Total amount enclosed \$ Check Money Order

Mail Coupon Today

ELECTRONICS

The phase shift of the transistor current gain also changes as a result of this shift in cutoff frequency. This change in phase shift requires the frequency of the oscillator to change to keep the oscillator coupling in proper phase at the oscillation frequency. When an audio signal is fed into the emitter of the transistor oscillator, the operating currents of the transistor are changed in accordance with the instantaneous magnitude of the audio signal. This changes the cutoff frequency of the transistor which in turn changes the frequency of oscillation of the oscillator in accordance with the change in instantaneous magnitude of the audio signal as explained above. This is frequency modulation by means of transistor current gain frequency-cut-off shift.

The function of R5 in the emitter circuit of the oscillator is not immediately apparent. It is used to prevent relaxation oscillations which may occur in v.h.f. point-contact transistors. These potential relaxation oscillations are due to emitter-to-ground capacitance combined with positive feedback through the internal base resistance of the transistor. The resistance R5 is placed directly on the transistor emitter terminal to isolate all other connections to the emitter and limit the emitter-to-ground capacitance to that due to the parasitic capacitance of the transistor and its socket. By holding down the total emitter-to-ground capacitance, the potential relaxation oscillations are avoided.

The diode V1 in the base of the oscillator provides emitter bias without recourse to a second potential source. R6 provides a d.c. emitter current path for the oscillator transistor which is of sufficiently high resistance to avoid shunting the audio input.

C3 and C4 are radio frequency bypass capacitors to return the v.h.f. frequencies in the emitter and collector directly to the base without passing through the biasing circuits.

The voltage and current required to operate the solar transmitter are only 4 volts and 3 milliamperes respectively. This represents a total power requirement of only 12 milliwatts. A 10-cell Bell solar battery of the type illustrated on the front cover has a normal open-circuit voltage of 5 and a total power output of about 250 milliwatts. That is why the transistor transmitter can be operated from such a battery even when the weather is cloudy.

No antenna is shown coupled to the oscillator tank circuit. This is deliberate, to limit the range of transmission to the few hundred feet required for experimental and demonstration purposes. With a suitable antenna and under ideal conditions this range could probably be extended to a distance of several miles. A standard commercial FM receiver is now being used to receive the signals transmitted by the solar-powered transmitter. **END**

WHEN YOU THINK OF TUNERS, THINK OF COLLINS AUDIO PRODUCTS



Announcing
A Distinguished Business Opportunity
A *Muzak* FRANCHISE

Some fortunate business man in your area will shortly be appointed an exclusive MUZAK franchiser. *That man could be you!*

For the past 20 years MUZAK, the originator and pioneer of functional background music, has been serving many of the best known hotels, restaurants, banks, offices, factories, and similar places of business, in key metropolitan areas.

Now, thanks to an exclusive MUZAK engineering triumph—a new automatic high-fidelity multi-channel tape transmission instrument—costs of franchise operation have been so reduced that markets down to 50,000 (and even less) population can hand-somely support a MUZAK franchise.

No special technical knowledge is necessary; the entire MUZAK studio operation is push-button automatic. Equipment takes up a minimum of space, can be housed almost anywhere. A visit once a day to change reels is all that's normally required.

HERE ARE THE FACTS ON FUNCTIONAL BACKGROUND MUSIC!

Only Muzak—Muzak alone!—has music specifically selected, arranged, and recorded for one purpose only: functional background music to work to and relax to.

Only Muzak, with its library of 7,000 basic selections, has a reservoir of music large enough to permit scientific, non-repetitive programming. So valuable is this big library that MUZAK protects each selection by "watermarking" it indelibly yet inaudibly with electronic impulses which spell out MUZAK on the tape.

Only Muzak has different programs each set up to meet the special psychological needs of three different markets: factories; offices; and public places like hotels, restaurants, banks, and others.

Only Muzak is true background music. Other music, such as radio transcriptions and record music, is primarily entertainment music. Its jarring contrasts of rhythm, mood, and loudness may have an effect exactly opposite from that of pure background music.

With Muzak, you—and your subscribers!—are sure!

Not Just Another Music Service, But Muzak! The Only Planned Background Music in Existence!

To get the whole story, send in the coupon or phone or wire MUZAK today.



MUZAK CORPORATION, Dept. RE
 229 Fourth Avenue, New York 3, New York
 Phone: ORchard 4-7400

I'm interested in becoming a MUZAK Franchiser. Please send me your booklet "A Distinguished Business Opportunity: A MUZAK Franchise"

Name _____
 Title _____
 Affiliation _____
 Type of Business _____
 St. _____ City & Zone _____ State _____

printed circuit I.F.'S

for HI-FI FM TUNERS

*Special circuits prevent FM
oscillator drift and
alignment loss*

By **ROBERT GRODINSKY***

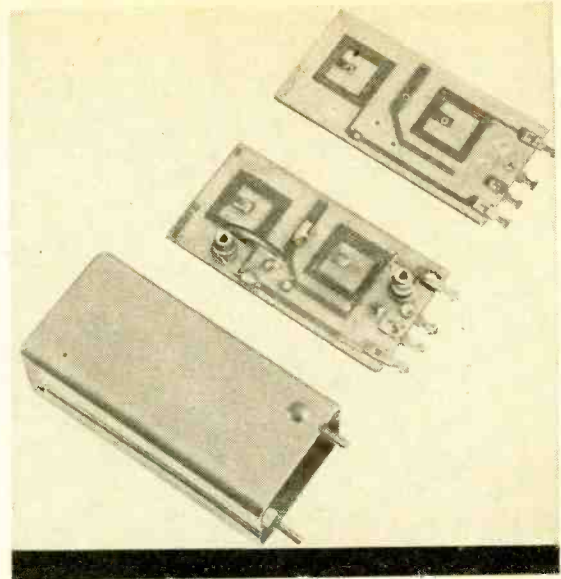

Fig. 1—Printed i.f. transformers

LACK of stability in the 100 mc band used by FM has always been a problem to the set designer. The first commercial FM sets suffered from oscillator drift which made necessary a warmup period and constant retuning. The use of automatic frequency control circuits and temperature-compensating components eliminated this type of drift in most commercial sets by 1948.

A second type of instability, and one more difficult to correct, is loss of alignment in the r.f. and i.f. circuits over a long period of time. I.f. circuit stability depends upon thermal effects, capacitive changes due to tubes, and the mechanical stability of the i.f. transformer design. A printed type i.f. circuit eliminates the thermal and mechanical factors, and if the design values are properly chosen, capacitive changes due to tubes can be greatly minimized.

In designing i.f. circuits for FM reception, bandwidth must be considered in a way not recognized several years ago. The relationship between phase modulation and frequency modulation is well known, but the fact that the phase shift produced in a tuned circuit creates distortion in an FM system was recognized only a few years ago.¹ Since the phase angle varies along the slopes of a tuned circuit, this is equivalent to frequency modulation which was not contained in the original signal. Extraneous modulation of this type is distortion. For example, in an i.f. system whose 6-db bandwidth is 200 kc, the intermodulation distortion is generally at a minimum of 0.5%. In an i.f. system of 125 kc bandwidth, the distortion is

1.5%. The ideal bandpass for minimum distortion is one in which there is little or no phase shift over the full working range, which in commercial broadcasting means a bandwidth of 150 kc without phase shift. Since phase shift and amplitude variation go hand in hand, this requires a flat-topped bandpass characteristic.

Flat-topped i.f. transformers have been designed for many years. However, to obtain an accurately controlled coupling factor in the transformer is difficult with standard wire-wound slug-tuned type of construction. The difficulty in manufacturing is due to the coupling factor or "QK" of the coils, a function of inductive and capacitive coupling. In a standard slug-tuned type of coil the physical relationship of the slugs to each other influences, to a large measure, the K or coupling factor. Tuning the circuits by adjusting the slugs changes the coupling, thus the same transformer may produce under-coupling in one set and over-coupling in another although properly tuned in each case. Capacitive tuning would help correct this, but the spacing of the primary and secondary coils must be very closely controlled during manufacture. The printed type i.f. circuit offers a definite advantage here since the coil spacing can be controlled in production to very close tolerances.

Printed circuit

The i.f. circuit which evolves from these considerations is seen in Fig. 1. Fig. 2 is a picture of the Craftsmen C900 tuner in which these printed i.f. transformers are used. The coil itself is of two-sided construction, that is, coil elements are photo-etched on both sides of the base material. This type of coil is more expensive to make than one etched on only one side, but it is necessary to obtain the Q's needed for this design. Silver mica tuning capacitors are wired directly to the

board as are the ceramic trimmers. The base material is glass melamine, chosen for its extremely low moisture absorption and small coefficient of thermal expansion. The thickness of the base material is held to close tolerances since this controls the mutual inductance between opposite sides of the board. The operating center frequency is 20.6 mc. The bandpass of a single i.f. transformer is shown in Fig. 3. The markers pictured are 20.6 mc, plus and minus 150 kc. In manufacturing, each i.f. transformer is individually adjusted for this flat-top characteristic. As can be seen, the flat portion of the nose easily extends plus or minus 75 kc.

The tuning capacitor used is 50 μf . Though this results in a lower impedance, and therefore a lower gain per i.f. stage, the input or output capacitance of the i.f. tubes used in this circuit then represent only 8% of the total capacitance. This means that normal tube variations in capacitance represent only 0.5% of the total. Since most commercial i.f. amplifier designs today use capacitors of about 25 μf , the stability in terms of tube replaceability is improved by more than 2 to 1.

The i.f. of 20.6 mc was chosen to minimize interference. When an i.f. of 10.7 mc is used, the most common interfering image is the one where two stations, spaced approximately 10.7 mc apart, heterodyne in the mixer circuit and interfere with one another. Since the FM band is only 20 mc wide, using a 20.6-mc i.f. eliminates this possibility. It also allows the operation of several sets simultaneously from one antenna since in no case can one set's oscillator be picked up by another set.

Standard printed circuit etching techniques are used in the manufacture of these i.f. transformers except that the degree of control must be greater than that used for less critical circuits,

*Project Engineer, The Radio Craftsmen, Inc.

¹J. J. Hupert, "A method of evaluation of the quasi-stationary distortion of FM signals in tuned interstages," Proc. National Electronics Conference (Chicago); 1952.

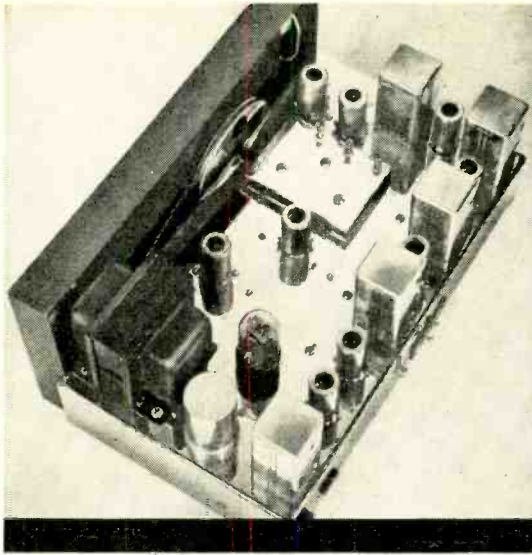

Fig. 2—Top, the Craftsman C900 tuner.

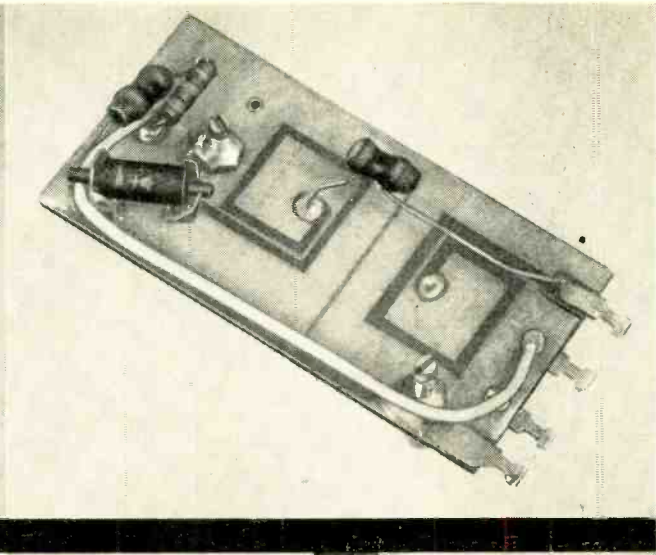
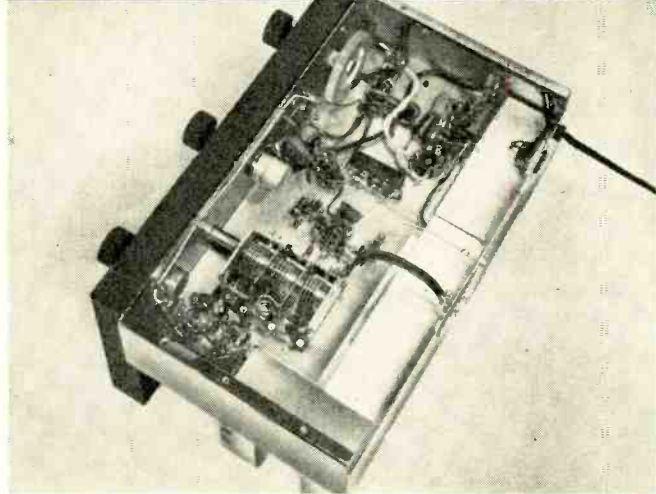

Fig. 4—Top right, discriminator circuit.

Fig. 5—Right, Plates shield i.f. strip.



such as etched wiring. The fact that both sides of the base material have to be in register also complicates their manufacture. After etching, the coils are separated and punched. Hand assembly is used for the capacitors and trimmers, after which the coils are baked for 20 hours to eliminate moisture, and then wax-dipped. Each coil is checked in a test jig which simulates the circuit in which it is to be used. The coils are prealigned by a sweep generator and marker signals. By checking each coil for bandwidth and coupling, final alignment of the i.f. strip in the set is greatly simplified.

The discriminator transformer is also a two-sided type of printed coil. The construction is similar to that of the i.f. transformer except that the unit also contains load resistors and

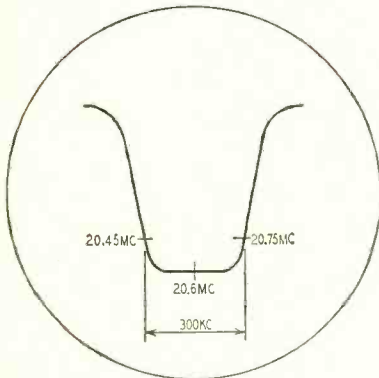

Fig. 3—Bandpass of single i.f. transformer. Center frequency is 20.6 mc.

the detector diodes. (See Fig. 4.) Using such a completely shielded, self-contained type of discriminator-detector minimizes the possibility of the high-level i.f. voltages coupling back into an earlier stage and causing regeneration. The peak-to-peak bandwidth of the discriminator is extremely wide—425 kc—to assure almost perfect linearity over an FM channel. In pro-

duction, each discriminator is aligned for minimum intermodulation distortion. Because of the low phase shift in the i.f. stages and the excellent discriminator linearity, over-all distortion can be held to 0.1% or less for a deviation of plus or minus 75-ke. This magnitude of distortion is far better than the best broadcasting equipment used today. Thus, this tuner becomes one of the strongest links in the chain of FM reception.

Even though the bandpass characteristic of each individual i.f. strip is properly adjusted, the over-all i.f. characteristic will not be perfect unless regeneration in the i.f. strip is made extremely small. Any regeneration present will produce phase shift and distort the bandpass characteristic. Therefore, the bypassing and physical layout of the i.f. strip is a very important part of securing low-distortion FM reception. Neutralization of each i.f. stage is one technique used to minimize regeneration. One of the most common and worst forms of regeneration is due to the high-level energy of the limiter and discriminator circuits coupling or "blowing back" into earlier stages. In the C900 this effect was minimized by building a completely enclosed i.f. strip. Fig. 5 is the bottom

view of an assembled chassis. The plates are used to enclose the discriminator, limiters and i.f. strip completely. This shielding along with the corner of the chassis provides a waveguide whose cutoff frequency is about 380 mc. As in all waveguides, the transmission below cutoff frequencies is very small, thus the blow-back form of regeneration is greatly reduced. In addition to this, a 20.6-mc filter is inserted in the audio output of the discriminator so that no intermediate frequency is fed back through the receiver's audio amplifier.

To complement these excellent low-distortion characteristics of the i.f. strip and discriminator, high sensitivity and amplified a.f.c. were built into the front end. The C900 contains a cascade r.f. stage. This type of dual-diode input results in the lowest possible input-circuit noise and therefore the highest sensitivity of any circuit in use today. Over-all sensitivity of the C900 is 2 microvolts for 30 db of quieting. To insure correct tuning, an a.f.c. circuit which includes a d.c. amplifier is used. The effective correction factor of this circuit is 30 db. This means an initial tuning error of 75 kc, for example, will be reduced to 2.5 kc. Conventional a.f.c. used in most

Electrical Engineering

or

Physics Graduates

Here is an ideal way for the engineer or physicist with some aptitude for writing to enter the field of advanced electronics. In this relatively new and expanding area you can make immediate and effective use of your academic training while acquiring additional experience.

Hughes Research and Development Laboratories are engaged in a continuing program for design and manufacture of integrated radar and fire control systems in military all-weather interceptor aircraft. Engineers who produce the maintenance and operational handbooks for this equipment work directly with engineers and scientists engaged in development of radar fire control systems, electronic computers, and other advanced electronic systems, devices.

Your effort in the field of engineering writing through these publications transmits information to other engineers and technical personnel on operation, maintenance and modification of Hughes equipment in the field.

You will receive additional training in the Laboratories at full pay to become familiar with Hughes equipment. Seminars are conducted by publications specialists to orient new writers. After-hours graduate courses under Company sponsorship are available at nearby universities.

Relocation of the applicant must not disrupt an urgent military project.

Scientific and Engineering Staff

Hughes

RESEARCH AND
DEVELOPMENT LABORATORIES

Culver City, Los Angeles County, Calif.

RADIO

sets today provides a maximum of 14 to 15 db of correction which, under the same circumstances, would reduce a 75-ke tuning error to 13 kc.

(The 30 db figure referred to is the voltage ratio of the d.c. voltages out of the discriminator with and without a.f.c., with the system deliberately off tune. Since the discriminator represents a linear transfer function between frequency and d.c. voltage over its operating range, the ratio of d.c. voltages corresponds to the frequency ratio. I illustrate this by indicating that an initial tuning error of 75 kc with no a.f.c. would be reduced to 2.5 kc when the a.f.c. is full on. This was based on approximating the 30 db as a 30 to 1 voltage ratio. It seems an obvious analogy to use db's of a.f.c. correction in the same sense that one uses db's in negative feedback.)

The amount of correction can be controlled from the front panel. This is preferable to an a.f.c. off-on switch in that it allows any desired degree of a.f.c. to be used when receiving strong or weak channels instead of disabling the a.f.c. completely. In spite of the degree of a.f.c. correction, the pull-in, pull-out range has been held down by designing the a.f.c. amplifier for sharp-cutoff characteristics.

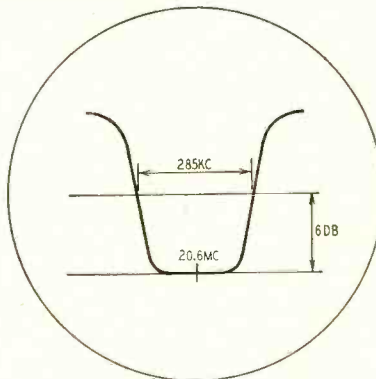

Fig. 6—The over-all i.f. bandwidth.

Automatic volume control is included in this design to maintain the i.f. band-pass characteristics during large signal inputs. Without a.v.c. the first three i.f. circuits would detune due to Miller effect if allowed to draw grid current. This would degrade the flat-top i.f. bandpass curve (Fig. 6). The a.v.c. voltage is generated in a grid-limiting R-C network in the grid circuit of the third i.f. amplifier. The negative a.v.c. voltage thus generated is filtered and applied to the input grid of the cascade r.f. amplifier. Since approximately 70 microvolts of input signal is needed to generate a.v.c. voltage, the full gain of the receiver is available to assure adequate early quieting.

The combining of all these features results in an FM tuner which possesses high stability and sensitivity and near perfection of distortion reduction; a tuner which poses a challenge to the broadcast industry to reduce FM transmitter distortion to approximately the same degree.

The COMPLETE line



Public Address need!



WRITE NOW
for FREE Catalog 553



**ATLAS
SOUND CORP.**
1443 39th St., Brooklyn 18, N. Y.
In Canada: Atlas Radio Corp., Ltd., Toronto, Ont.

Concord's BUY OF THE MONTH

VEE-DX 9 ELEMENT ALL-CHANNEL VHF YAGI
\$12.95
Reg. Price \$38.85
Lots of 3 \$11.95

One of the most fabulous antenna values ever offered. A chance to solve your stock and inventory problems with 1 antenna for all single channels. And talk about bargains! This antenna Regularly Lists at \$38.85. You SAVE \$25.90 on every one that you buy! Combines all the desirable features of a yagi, yet with all-channel performance. One easy-to-install antenna eliminates the need for separate yagis for each channel. Provides top performance at lowest cost. The VEE-D-Xtra Special is a 9-element hi-low yagi: 5 elements on high, Delta Matched 4 elements on low—new isolation filter (MM-25) the outstanding all-channel VHF antenna. Shpg. wt. 7 lbs. — Stock No. C-SP1

FREE! NEW 1954 CATALOG!
A complete, comprehensive listing of all your electronic requirements. Bursting with SPECIAL VALUES

Dept C8
CONCORD RADIO MINIMUM ORDER \$5.00
20% deposit with C.O.D.
 Send new 1954 CONCORD CATALOG!
NAME _____
ADDRESS _____
CITY _____ ZONE _____ STATE _____

**CONCORD RADIO • 54 VESEY ST.
NEW YORK 7, N. Y. • DIgby 9-1132**

NOW **any** selenium rectifier
can be replaced with a

Federal

Federal's
COMPACTED • EYELET TYPE
UNIVERSAL LINE

meets all replacement needs
where size is a factor

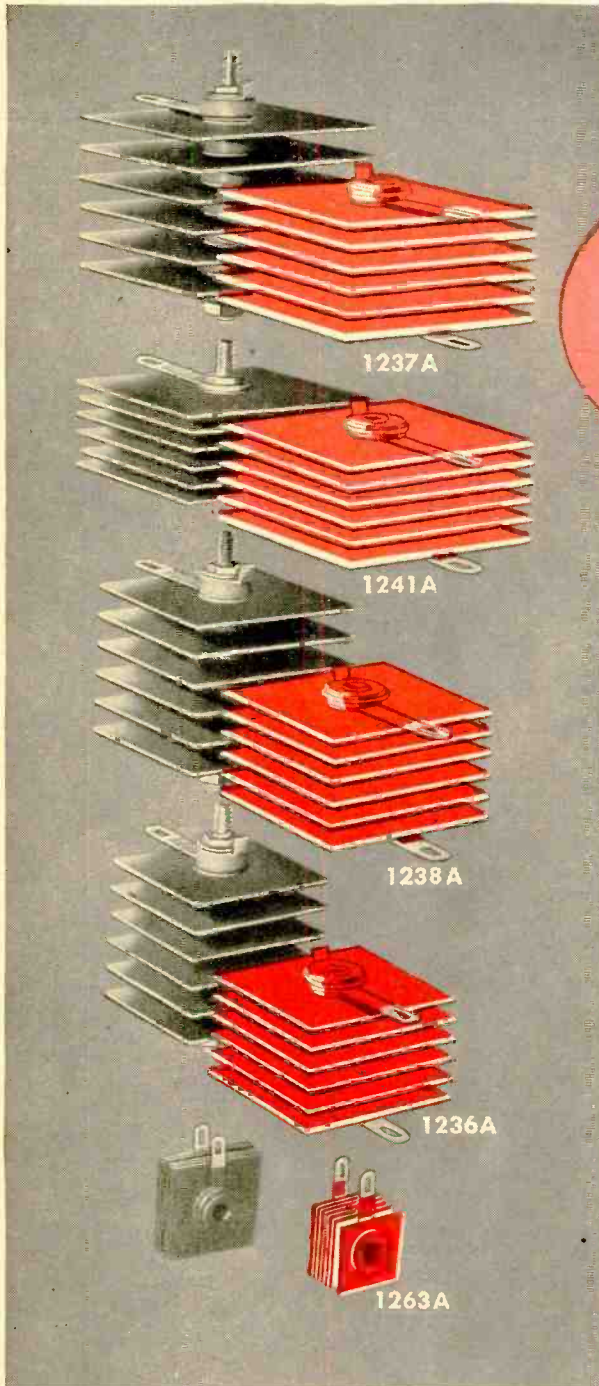

Federal Selenium Rectifiers are listed in
Howard W. Sam's Counter-Facts and Photo Facts.

ONE SOURCE OF SUPPLY

... Federal's Universal and Regular Lines
provide complete coverage of today's
selenium rectifier requirements!

SERVICEMEN! Now you can buy all the selenium rectifier
types you'll ever need ... from Federal!

Whatever the make or rating of the rectifier being re-
placed, Federal's new, smaller-size *Universal Line*—or Federal's
Regular Line—will meet all requirements!

The Universal Line's smaller "H" dimension does the
job where space is a factor. The five types are listed below.
All are eyelet construction, with 6/32" mounting screw
enclosed. They are designed to handle approximately 70%
of all replacements.

Make *your* servicing job easier ... more profitable ... by
simplifying rectifier procurement. Get *uniform* quality, de-
pendability and performance—plus *long, long life*—by re-
placing with Federal's *Universal* and *Regular* Lines ... in
the easy-to-identify "Rectifier Red." Ask your distributor,
or write to Dept. F-363.

UNIVERSAL LINE RATINGS AND DIMENSIONS:

Type	Max. DC Ma.	"H" Dim. Max.	Plate Size
1263A	65	21/32" ± 1/32"	11/16" Sq.
1236A	300	1-3/8" ± 1/32"	1-5/8" Sq.
1238A	350	1-3/8" ± 1/32"	1-3/4" Sq.
1241A	400	1-1/4" ± 1/32"	2" Sq.
1237A	500	1-3/8" ± 1/32"	2" Sq.

Federal has available a new type bolt and nut for mounting rectifiers
in tandem. Order bolts by Part No. IDR-6131; nuts by Part No. IDR-6015.



America's first and largest manufacturer of selenium rectifiers

Federal Telephone and Radio Company

A Division of INTERNATIONAL TELEPHONE AND TELEGRAPH CORPORATION
COMPONENTS DIVISION 100 KINGSLAND ROAD CLIFTON, N. J.
In Canada: Federal Electric Manufacturing Company, Ltd., Montreal, P. Q.
Export Distributors: International Standard Electric Corp., 67 Broad St., N. Y.



Federal
"S-C-S"
GERMANIUM
DIODES!

—in the industry's
most useful
PACKAGE LINE!
Ask your
Distributor!

REGENERATIVE TRANSISTOR RECEIVER

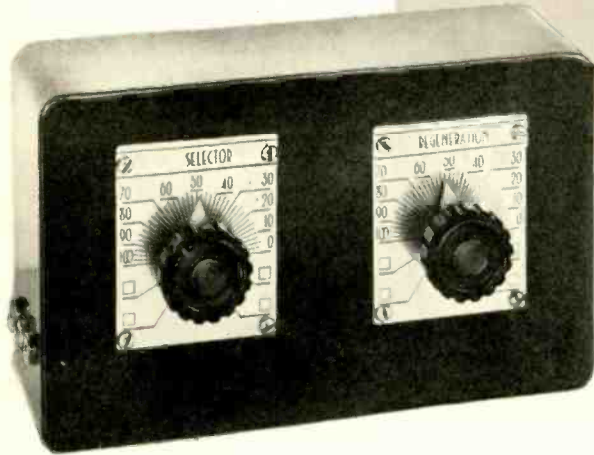

This sensitive and selective unit contains regenerative detector and audio amplifier

By DR. WILLIAM H. GRACE, JR.

THIS compact regenerative receiver has given more than ample ear-phone volume on broadcast stations located several hundred miles away. When used with a 60-foot outside antenna, stations well beyond 1,000 miles have been repeatedly heard right through the numerous superpowered N. Y. C. locals. This indicates its sensitivity and selectivity. The receiver makes a reliable receptor for emergency use during power failure should a sudden air attack occur. Though built for use with earphones, many of the local broadcasting stations can be received at moderate room volume on a 10-inch PM speaker with a suitable matching transformer.

Construction

A black bakelite meter case was used for the cabinet, the outside dimensions being 3.75 x 6.25 x 2 inches. The set is built within the cabinet rather than on a separate panel. This construction simplifies the assembly and permits mounting the smaller components on a little shelf directly above the trimmer capacitor. This small variable capacitor is the regeneration control and provides the necessary capacitance feedback for oscillation. The shelf is suspended by small-sized L-brackets, very easily attached by hex nuts to the projecting machine screws that hold the dial plates in position on the front of the panel. This idea works nicely and eliminates the drilling of extra holes in the cabinet.

The circuit is a standard grounded-emitter type with the first transistor acting as a regenerative detector and the second as a transformer-coupled audio amplifier (Fig. 1). Both transistors are Raytheon junction type CK

722, that operate satisfactorily on only 4.5 volts. Other types of transistors would likely work as well or better; the CK722's were chosen because of their availability and lower cost. These crystal triodes are durable and have a long life if reasonable precautions are taken to prevent burnouts. The negative side of the battery must be connected to the collectors as indicated in the diagram. Transistors—and the manufacturer's specifications—often vary widely; newer models may run more consistent in this respect. I found it advisable to hook the circuit up breadboard style to test the transistors in operation before assembly in the cabinet, as the transistors are soldered directly in the circuit (no sockets being used).

The antenna requirements of any practical emergency receiver must be flexible. Thus, two separate antenna connections have been provided. On the left side of the cabinet are 3 phone-tip jacks. The two nearest the rear are for antenna connections, the third is for ground. In series with J1 and the main tuning capacitor (C3), is C1, one of the antenna coupling capacitors. The J1 connection is used only with a short, 20- or 25-foot antenna, plus a ground connection. It is often possible to obtain good results with J1 connected to the shell of a floor lamp or table lamp, the shell of a telephone box, or to one side of an a.c. outlet. No ground connection is made if any of the above antenna substitutes are used. This precaution is necessary because of the possibility of a short in C1. There will be only a very slight loss in volume by so doing. Capacitor C2 is in series with J2; this connection is used when a longer outside antenna (60 to 100 feet)

is available. Two 3-foot lengths of flexible wire, phone tips at one end and alligator clips at the other, furnish the actual connection from set to antenna and ground. Of course, the greatest volume and best dx will be obtained with an efficient outside antenna as high above ground as possible.

Inductor L1 is a standard Ferri Loopstick coil; and L2 is approximately 5 turns of No. 30 enamel wire, wound directly over the cardboard covering of the Ferri coil. The constructor should experiment with a greater or lesser number of turns on L2. In general, a few turns more than 5 will give greater volume and less selectivity, while fewer turns result in slightly lessened volume but increased selectivity. Incidentally, if oscillation is not obtained, reverse the leads to L2; this is the same as reversing the leads to the tickler coil in a regenerative tube receiver. The coil is mounted in the upper right-hand corner of the cabinet, rear view. The projecting dial plate screw again becomes useful.

The choke prevents r.f. from entering the audio circuit. Smooth regeneration will not take place if this choke is omitted. I found it convenient to mount the choke on the under side of the shelf just to the right of the trimmer capacitor.

The audio transformer is connected *backward*, that is, the high impedance winding is in the collector circuit. This is done to satisfy the impedance requirements of the transistors which can be considered to be opposite to tube triodes in respect to input and output impedances. The colored wire leads shown in the diagram are for the UTC type SSO-2 subsubouncer transformer. In conventional circuits using trans-

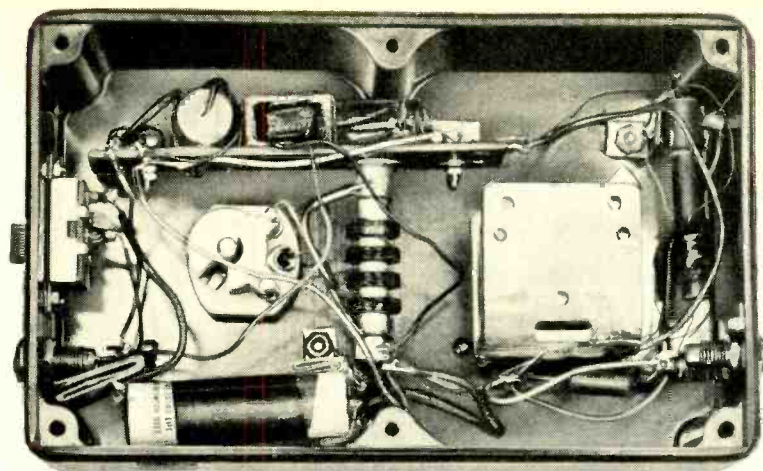

Internal view. The transistors are near the ends of the mounting strip.

former coupling with transistors, a base resistor is indicated from the base to the minus side of the battery. But with the particular CK722 used in this case no advantage seemed to be gained. The builder should experiment with this connection. The exact value of this resistor can best be found by test; any value between 220,000 ohms and 2 megohms may prove suitable.

Both transistors, C5 and C6, and the audio transformer were mounted directly on the shelf. Capacitor C6 could well be of greater value, but the value suggested does work satisfactorily. If better base response is desired, shunt this capacitor with one of equal value. The objection to using a larger value, say 5 μ f is that the actual physical size of such a capacitor prevents getting it into the cabinet.

The battery switch and the phone output jacks are mounted at the right side of the cabinet, front view. Any type of battery switch may be used; a sliding type was chosen because it happened to be at hand. It is a good precaution to mount the switch so that the ON position is as obvious as possible. In this way there will be less chance of forgetting to turn off the set.

The battery requirements of this receiver are easily met by 3 penlite cells. The cells are taped together edgewise, connected in series to furnish 4.5 volts. The minus lead from the battery goes to one switch terminal, the positive lead to ground. The cells are soldered, as far as their leads are concerned, directly into the circuit since they will seldom need replacement because of the

very low current drain of the two transistors. The total drain for both transistors is about 1 ma, hence the cells should last almost their normal shelf life with average use. A convenient way to anchor the cells is with two more L brackets fastened again to the two projecting machine screws from the dial plates. Small pieces of folded cardboard wedge the three cells to prevent them from slipping sideways.

Capacitor C3 is a miniature 365- μ f tuning capacitor. A standard broadcast capacitor could be used, but I found the smaller one easier to mount.

Operation

With only two controls the operation of the receiver is simplicity itself. The left-hand knob controls the frequency; the right-hand knob controls the volume, by varying the degree of feedback. It is comparable to the operation of any other regenerative-type of tuner. No other volume control was used in the circuit. If still greater volume is required it would be an easy matter to add a second stage of audio amplification. In this case a separate volume control would be necessary, and space on the front of the cabinet has been provided for this control just between the two dial plates.

Regeneration

Failure to obtain regeneration may be due, in the majority of instances, to incorrect coil connections. Fig. 2 shows the exact method of connecting L1 and L2. If there is any doubt as to which is the *start* of the winding on the Ferri

Loopstick and which is the *ending*, the following may prove helpful. Using a sharp knife, remove the cardboard covering protecting the coil winding. The starting and ending lead will now be visible. Care must be taken in doing this, or the coil winding will be damaged.

Another common cause of failure to obtain regeneration is due to the actual variation in the transistors themselves. Some CK722's are good oscillators and good rectifiers, others are not as efficient as detectors, and still others do not seem to oscillate or regenerate at all. Fortunately, a large percentage of those tested perform very well. We should realize that these transistors were not designed for regenerative purposes. CK722 transistors were built as low-power audio amplifiers and are for low-frequency purposes. However, they will work very nicely over most of the broadcast band as r.f. rectifiers. When a particularly good one is found it acts as a very sensitive detector just at the point of oscillation. In fact, when operated under the conditions described the sensitivity is remarkable and regeneration is fairly stable.

About the only other common or likely cause for lack of regeneration is a gross error in the circuit hookup. Worn-out dry cells will also produce poor results.

This receiver is very simple to construct, using the minimum number of parts and but two transistors. It will prove an interesting introduction to the transistor field for anybody interested

Parts for regenerative receiver

- 1—14 μ f, 1—.001 μ f, mica or ceramic capacitors;
- 2—1 μ f, miniature, paper capacitors; 1—50 μ f, trimmer capacitor with 1/4-inch shaft; 1—365 μ f, miniature, tuning capacitor; 1—transformer, primary impedance 10,000 ohms, secondary impedance 90,000 ohms, (UTC SSO-2 subsubouncer); 1—Ferri-Loopstick, bracket mounting type; 1—coil, 5 to 7 turns of No. 30 enameled wire; 1—r.f. choke, 2.5 mh;
- 2—Raytheon CK722 transistors; 1—case, 3.75 x 6.25 x 2 inches (Waldon utility case, model BC-138; panel, BB-137); 5—phone-tip jacks; 3—penlite cells; 1—s.p.s.t. switch; 6—small L brackets; 2—phone tips; 2—alligator clips.

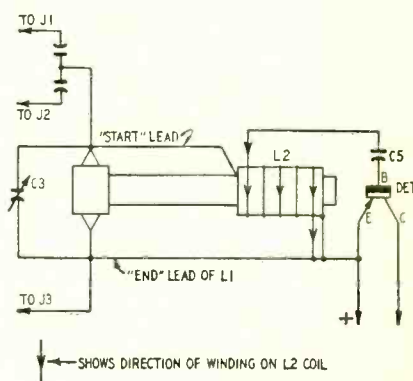

Fig. 2—Diagram of L1-L2 connection.

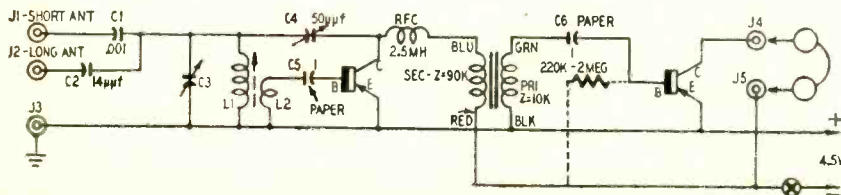

Fig. 1—Schematic of the 2-transistor radio. Circuit is grounded-emitter.

in these modern devices. The performance of this little rig proved ample reward for the few hours needed for its assembly.

END

The TARZIAN TUNER

UV 13

All Channel
Combination UHF-VHF

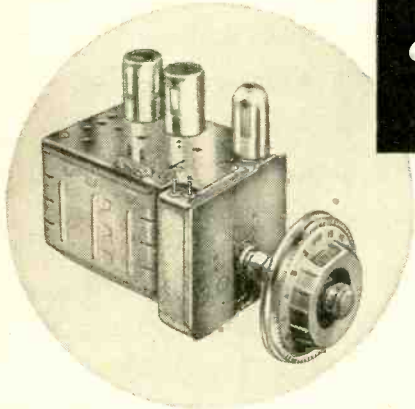

- A compact, combination tuner (the world's smallest) for covering the entire UHF-VHF bands.
- Straight line electrical sequence of compartmented circuits.
- Simple, coaxial tuning.
- Stage shielded.
- OVERALL PERFORMANCE MAKES ANY SET A BETTER SET.



Write for folder covering complete description and performance data.

SARKES TARZIAN, Inc.
Tuner Division
Bloomington, Indiana

RECEIVING TUBES

THREE TOP BRANDS ONLY
AT TREMENDOUS SAVINGS OVER
REGULAR WHOLESALE

OTHER TUBES AVAILABLE AT SAME LOW, LOW PRICES

Latest Code Dates • Boxed • Fully RTMA Guaranteed

OZ4 .62	6AK5 1.30	6BQ7 1.42	12AU7 .85
1B3 .95	6AL5 .63	6BZ7 1.52	12BA6 .73
1X2 1.06	6AQ5 .76	6CB6 .76	12BE6 .78
5U4 .63	6AU6 .67	6J6 .92	12SA7 .80
5Y3 .48	6AV6 .60	6K6 .65	12SK7 .77
6AB4 .80	6BA6 .71	6SN7 .85	12SQ7 .67
6AC7 1.25	6BG6 1.98	6V6GT .75	35W4 .49
6AG5 .83	6BK7 1.28	6W4 .70	35Z5 .51
6AH6 1.40	6BQ6 1.42	12AT7 1.05	50L6 .75

Brand New Pix Tubes Full One Year Guarantee
AUGUST SPECIAL! 20CP4 17.95 WITH OLD TUBE

With Old Tube		With Old Tube	
10BP4 10.45	9.95	16GP4 20.45	16.95
12LP4 12.95	11.95	16RP4 18.95	15.95
12LP4A 14.50	11.95	17BP4 20.95	16.95
12QP4 12.95	11.95	17CP4 20.95	17.95
14CP4 14.95	13.95	19AP4 23.45	19.95
15AP4 15.95	14.95	19AP4A 23.95	19.95
16AP4 18.45	16.95	20CP4 25.45	19.95
16CP4A 19.45	15.95	20HP4 26.95	20.95
16DP4A 17.45	15.95	21EP4 26.95	20.95
16EP4A 20.45	16.95	21AP4 26.95	21.95
16FP4 17.45	15.95	21FP4 27.95	21.95

Send for FREE catalog of additional tubes and parts

STUART ELECTRONICS DISTRIBUTORS

Dept. E-7

Minimum Order \$10.00

149-09 Union Turnpike
Flushing 67, N. Y.
OLympia 8-3553, 4352

TERMS: 25% Check or Money Order, Balance C.O.D., F.O.B. New York. Satisfaction Guaranteed or money back in 10 days.

RADIO

TRANSISTOR DOT MAKER

A series of dots gets more attention and is less tiring than a continuous tone. It can be used to modulate a signal generator or as a standby signal while adjusting a phone transmitter, wireless phono attachment, or intercom. A dot generator can also be used as a signal source for remotely controlling a model plane or for speed key practice without a Vibroplex or other automatic key. One of the simplest possible dot generators can be made with a junction type transistor and an audio transformer. (See diagram).

The transformer is connected in a conventional feedback circuit. If it has

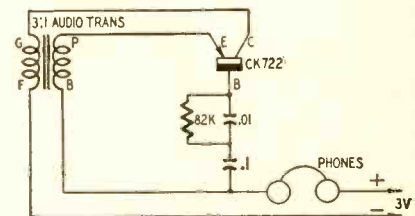

a third winding (as in a transceiver transformer) the added coil may be used as the output winding. The transistor base is isolated by a capacitor. Thus the oscillations build up, are blocked, and so on. With values shown, the dot rate is 2 a second. The power supply may be a 3-volt battery.

When the voltage is increased, the sound level increases, and the dots become more crisp. They become shorter with respect to the spaces between them. The rapidity of dots increases when a high resistance shunts the collector and base. For example, an 8.2-megohm resistor doubles the dot rate.

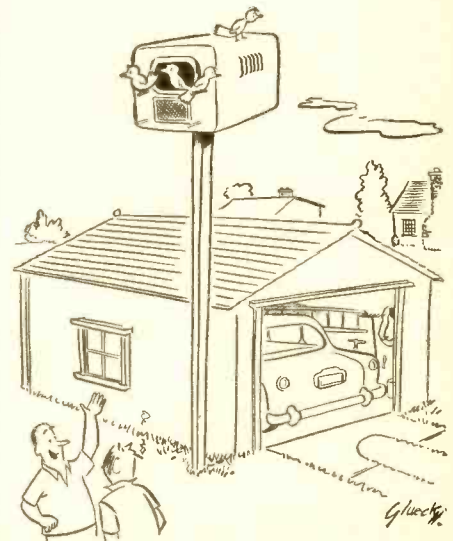

"It's an old seven inch set—"

JUNCTION TRANSISTORS

for high-frequency oscillators

Using the junction transistor as an i.f. and r.f. oscillator

By I. QUEEN
EDITORIAL ASSOCIATE

JUNCTION TYPE transistors are made and sold as low-frequency, low-power units. Catalog specs usually call for a certain minimum gain at 1 kc or perhaps 5 kc. No high-frequency specifications are given, but it is known that frequency response begins to droop early. Therefore it may surprise many readers to find that the junction transistor is efficient as an i.f. and r.f. oscillator. I have carried on many experiments with the CK722. Of several tried, all oscillated easily in the i.f. range near 400 and 500 kc. For most transistors tried, less than 1 volt was sufficient power supply. About half could oscillate above 1 mc! These active units required about 3 volts at this high frequency.

Transistors cannot be made as uniform as vacuum tubes. All transistors are efficient at audio frequencies, but even there it is usual to choose a bias resistor for the particular unit in the circuit. At intermediate and radio frequencies the nonuniformity is even more important. Substituting one transistor for another may call for retuning,

changing the applied voltage, or even redesigning the circuit. Often, the circuit must be designed around the transistor.

If you plan high-frequency experiments with a CK722 or similar transistor, and if you have access to several units, determine which are most active at r.f. or i.f. The more sluggish transistors may be set aside for a.f. circuits. Fig. 1 is a typical circuit for a crystal oscillator. Fig. 2 is a self-controlled oscillator. The values shown were found to work well for the particular transistors used. The base resistor, voltage supply, and base capacitor may need adjustment for best operation of your particular transistor.

In Fig. 1, the collector coil has to be tuned to approximately the crystal frequency. Due to transistor loading, the adjustment may vary with the particular transistor used. I obtained good results using a slug-tuned coil rather than a conventional capacitance-tuned tank.

The tank in Fig. 2 may be a single winding with an intermediate tap, or it may have two separate windings. The collector portion may be 3 or 5 times as large as the base winding. The windings must be correctly polarized. Connect them so that an electron starting out at the base will travel in the same direction around both coils to reach the collector. In other words, the winding should have the same effect as a single coil with an intermediate tap. If capacitor tuning is desired instead of slug-tuning, connect as shown by dotted lines in Fig. 2.

A broadcast oscillator coil is not suitable for a junction-transistor oscillator. Its frequency range is too high. Instead, use an antenna coil with primary, if you want a broadcast-band oscillator. A 455-kc i.f. transformer also makes a good tank. If used as is, it generates a signal near 300 kc. By removing turns, you can reach the broadcast band with it. As turns are taken off, monitor the frequency on a nearby receiver. The oscillator frequency equals the difference between consecutive beats. For example, if you hear signals at 600,

900 kc, etc., your frequency is 300 kc.

It is a good idea to leave a milliammeter or microammeter in series with the battery during experiments on the transistor oscillator. It offers a means of measuring the input to the transistor, and can indicate if the circuit is oscillating. Maximum input to a CK722 is 5 ma, but 1 or 2 ma is generally sufficient for a low-power oscillator. I obtained ample output in most circuits with an input of only 100 μ a. In any case, the current is controlled by the base resistance and the applied voltage, and depends on the individual transistor. A lower base resistance increases the current input and the power output.

Ordinarily, the amount of oscillating current differs from the nonoscillating flow. In a typical case, a current of 44 μ a flowed when the circuit was oscillating. In the nonoscillating condition, this dropped to 40 μ a. This circuit used a 470,000-ohm base resistance and 3 volts input. With a small base resistance, the oscillating value will be less than the nonoscillating current. For example, in the above circuit a 40,000-ohm resistor raised the oscillating current value to 0.5 ma. When not oscillating, it climbed to 0.65 ma. In any circuit the oscillations may be killed by simply shorting out one or both tank coils.

Knowing the oscillating and the non-oscillating current values can save much time. For example, if you are trying to increase frequency by removing coil turns, you can watch the meter to see whether oscillations are still present. After a while, the difference (between oscillating and nonoscillating readings) will narrow down. This shows that you are approaching the frequency limit of your transistor.

One remarkable thing about a transistor self-controlled oscillator is its stability. When properly designed, its signal will be clear as a crystal tone. A slug-tuned high-Q tank, using no shunt capacitance gives a better signal than most heavily capacitance-loaded tube oscillators. This is evidently due to the loading of the transistor itself. It is only when the oscillations are on the verge of dying out that the tone sounds poor. This can happen if you use too low a voltage on the transistor, or if you operate it too close to its frequency limit. It happened here during an experiment when I was using low voltage on a transistor oscillating near 700 kc, and the r.f. signal was modulated by spurious whistles, and hum. The trouble was that I had my meter on the 40- μ a range to measure the very low input current. On this range the meter has a resistance of 2,500 ohms. When I switched to the 1-ma range (100 ohms) the signal immediately became pure unmodulated r.f. again.

The base resistance of a self-controlled oscillator has a considerable effect on frequency. With one circuit I obtained a frequency of 780 kc. The base resistor was 470,000 ohms and the base capacitor 500 μ f. Changing the

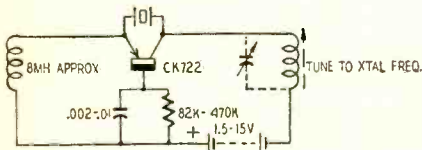

Fig. 1—Crystal oscillator circuit.

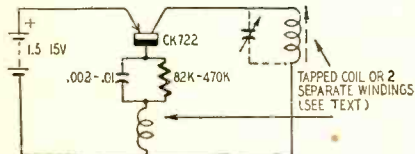

Fig. 2—A self-controlled oscillator.

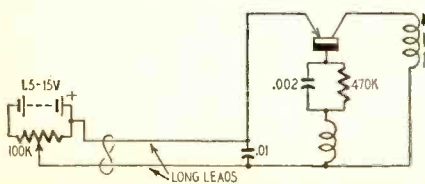

Fig. 3—Using resistance control.

ALL RADIO AND TV TYPES TUBES

**• STANDARD BRAND WARRANTY
• BRANDED
• BULK PACKED OR INDIVIDUALLY BOXED**

**CLOSE OUT!
SET MANUFACTURERS
CLOSE OUT**

**ONE OF AMERICA'S
LARGEST
WHOLESALEERS**

0A4G	\$.50	3LF4	\$.71	6CD6G	\$1.05	7E6	\$.60	12Z3	\$.50	39
02A	\$.49	3Q4	\$.48	6E5	\$.76	7E7	\$.80	14A7	\$.53	53
1A4P	\$.35	3Q5GT	\$.48	6F6	\$.45	7F7	\$.64	14AF7	\$.63	63
1A5	\$.30	3S4	\$.46	6HG7	\$.49	7F8	\$.92	14C5	\$.80	80
1A7GT	\$.45	3V4	\$.46	6J5GT	\$.34	7G7	\$.80	14C7	\$.65	65
1B3GT	\$.65	5U4G	\$.49	6J6	\$.50	7H7	\$.56	19	\$.35	35
1C5GT	\$.39	5V4G	\$.76	6J7	\$.49	7J7	\$.80	19B6G	1.15	115
1C7G	\$.35	5Y3G	\$.36	6K6GT	\$.51	7K7	\$.80	19T8	\$.61	61
1D7G	\$.35	6A6	\$.35	6K7G	\$.49	7L7	\$.80	25AV5	1.05	105
1E7GT	\$.35	6AR7	\$.63	6L6GA	\$.99	7NE	\$.57	25L6GT	\$.40	40
1F4	\$.39	6AC7	\$.68	6S4	\$.47	7R7	\$.59	25Z6GT	\$.37	37
1F5G	\$.35	6AG5	\$.46	6SA7	\$.59	7S7	\$.85	32L7GT	\$.39	39
1H4G	\$.35	6AH6	\$.88	6S7GT	\$.61	7V7	\$.87	35	\$.29	29
1H5GT	\$.38	6AK5	\$.69	6S7	\$.59	7Y4	\$.40	35	\$.29	29
1I6	\$.38	6AL5	\$.34	6SF5GT	\$.58	7X6	\$.57	35	\$.29	29
1L4	\$.47	6AQ5	\$.37	6S7	\$.59	7Z4	\$.40	35	\$.29	29
1L4	\$.71	6AQ5	\$.37	6S7	\$.59	7Z4	\$.40	35	\$.29	29
1L4	\$.71	6AQ5	\$.37	6S7	\$.59	7Z4	\$.40	35	\$.29	29
1LA6	\$.75	6AQ7GT	\$.69	6S7	\$.59	7Z4	\$.40	35	\$.29	29
1LB4	\$.77	6A55	\$.62	6SK7GT	\$.39	12A7	\$.38	35	\$.29	29
1LC5	\$.75	6AT6	\$.36	6SL7GT	\$.49	12AT6	\$.57	35	\$.29	29
1LC6	\$.75	6AU6	\$.36	6SN7GT	\$.46	12AT7	\$.57	35	\$.29	29
1LD5	\$.75	6AV5GT	\$.79	6SQ7GT	\$.49	12AU6	\$.59	35	\$.29	29
1LN5	\$.75	6AV6	\$.36	6S7GT	\$.49	12AU7	\$.59	35	\$.29	29
1LG5	\$.75	6BA6	\$.33	6T8	\$.57	12AV7	\$.60	35	\$.29	29
1LM4	\$.75	6BA7	\$.57	6U7	\$.49	12AX7	\$.62	35	\$.29	29
1LN5	\$.75	6BC5	\$.46	6U8	\$.59	12AY7	\$.72	35	\$.29	29
1NSGT	\$.61	6BE6	\$.37	6V3	1.04	12BA6	\$.52	35	\$.29	29
1Q5GT	\$.39	6BF5	\$.69	6VG7	\$.38	12B6A	\$.61	35	\$.29	29
1R4	\$.81	6BG6G	1.10	6W4GT	\$.41	12BD6	\$.46	35	\$.29	29
1R5	\$.46	6BM6	\$.45	6W6GT	\$.41	12BE6	\$.40	35	\$.29	29
1S4	\$.40	6BJ6	\$.46	6X4	\$.35	12BH7	\$.41	35	\$.29	29
1S5	\$.40	6BL7GT	\$.65	6XS7GT	\$.33	12H6	\$.49	35	\$.29	29
1T4	\$.46	6BN6	\$.88	7A4	\$.45	12SA7GT	\$.58	35	\$.29	29
1U4	\$.46	6BQ6GT	\$.69	7A7	\$.45	12SG7	\$.61	35	\$.29	29
1U5	\$.46	6BQ7	\$.88	7B5	\$.46	12SH7	\$.49	35	\$.29	29
1X2A	\$.65	6C4	\$.31	7B6	\$.45	12SK7	\$.49	35	\$.29	29
2A5	\$.39	6CSGT	\$.41	7B7	\$.45	12SN7GT	\$.46	35	\$.29	29
2A7	\$.35	6C6	\$.49	7C7	\$.53	12SQ7	\$.46	35	\$.29	29
2X2	\$.39	6CB6	\$.42	7E5	\$.80	12SR7	\$.49	35	\$.29	29

MINIMUM ORDER: \$10.00. Terms: 25% with order, balance C. O. D. Please include postage.
All prices subject to change without notice. F. O. B. New York City. Mail Order Division:

TRANSAMERICA ELECTRONICS CORP.

115 LIBERTY ST., NEW YORK 6, NEW YORK

RADIO

resistance to 40,000 ohms dropped the frequency to 700 kc. No other circuit change had been made. The lower base resistance also increased current input from 50 μ a to 600 μ a from the 1.5-volt battery. Obviously the output power also increased considerably.

Battery voltage affects frequency to a great extent. The following table illustrates this. The tank was a slug-tuned pair of coils wound over the same half-inch core. The collector winding had about 75 turns No. 28 enamelled wire and the base winding about 30. Each was close-wound with 7 turns per layer. The coils were about $\frac{1}{8}$ inch apart.

Voltage	Frequency	Current
1.5	700 kc	50 μ a
3.0	770 kc	120 μ a
4.5	800 kc	200 μ a
10.0	830 kc	650 μ a

The frequency control can be operated at a distance. For example, I used a remote 100,000-ohm potentiometer across a battery (Fig. 3). A .01- μ f capacitor bypassed the leads where they connect to the oscillator itself. Thus the remote network (potentiometer and battery) are bypassed. Of course, the power increases as we raise the frequency. If the circuit is to be used as a frequency modulator its output may be fed into a limiter to keep the power constant.

Frequency may also be controlled by a resistance in series with the battery. A 1,000-ohm resistor shifted frequency from 610 to 600 kc. This method is not suitable for remote control. It seems that the capacitance between leads cancels out some of the resistive effect. Unless the resistor is right at the circuit, much of its effect is lost through this capacitance.

The combination of an active transistor high-voltage supply (4.5 or more) and a high base resistor gives rise to an unusual effect. The circuit goes into multiple oscillations like a superregenerator or multivibrator. The output is composed of a strong carrier (at the frequency of the tank coil) and numerous sidebands. These frequencies may be spaced by about 3 kc or less. Thus, as the band is tuned, one signal comes in just as the next is leaving, so there is a more or less continuous signal. With a certain adjustment here, we obtained the carrier at 800 kc. The sidebands occupied a width of about 200 kc on either side. These sidebands are maximum near the carrier and become weaker as we tune away from it in either direction.

Of course the multiple signal appears on the short-wave bands as harmonics. Thus we hear a maximum signal at 1.6 mc, 2.4 mc, etc. In each case the noise signal is maximum near these frequencies but drops off to zero on either side. For a good noise signal, adjust the circuit so that the individual side frequencies merge or blend to become continuous. Such a noise is fine for alignment or adjustment of a receiver, and for many test purposes. END

OSCILLOSCOPES

ARE
"GOLD
MINES"!

... if you learn how to use them fully on all types of service jobs!



Learn to handle the oscilloscope fully on all types of AM, FM and TV service work—and watch your efficiency and earnings soar!

MODERN OSCILLOSCOPES AND THEIR USES, a fact-packed 326-page book by Jacob H. Ruiter, Jr., of the Allen B. DuMont Laboratories, contains exactly the help you need—written in a way you can clearly understand. It shows you how to use your "scope" for fast accurate work on all types of jobs from troubleshooting to realigning; how to make connections; how to adjust circuit components; how to set controls and how to analyze patterns fast and accurately. 370 helpful illustrations including dozens of pattern photos make things doubly clear.

No other type of specific service training stands to mean so much to you in terms of being able to do better, faster, and more profitable work!

When, where, why and exactly how to use oscilloscopes

How to interpret oscilloscope patterns

How to handle tough jobs in less time

PRACTICE 10 DAYS FREE!

Dept. RE-84, RINEHART & COMPANY, Inc.
232 Madison Ave., New York 16, N. Y.

Send MODERN OSCILLOSCOPES AND THEIR USES for 10 DAY EXAMINATION. If I decide to keep the book, I will then remit \$6.00 plus a few cents postage in full payment. If not, I will return book postpaid and owe you nothing.

Name

Address

City, Zone, State

Employer's Name & Address

OUTSIDE U.S.A.—Price \$6.50 cash only. Money back in 10 days if book is returned.

RADELCO

LIGHTNING ARRESTOR
FITS FLAT, OVAL, ROUND
AND OPEN CABLES!

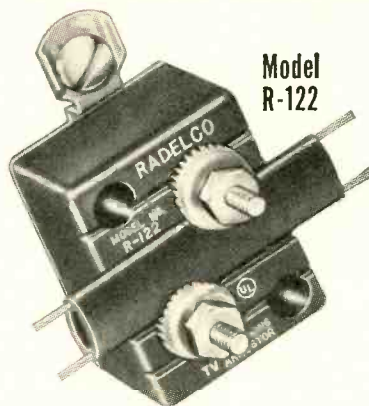

Model R-122

IT'S NEW! IT'S BETTER!

The only Underwriters Listed UHF-VHF Lightning Arrestor selling at 90c list.

ORDER FROM
YOUR NEAREST
PARTS JOBBER

LIST PRICE
90c

Wait'll you see what

Centralab

has
up its
sleeve!



It's the most important
development in years
in
dual concentric
controls!

Watch for early
Centralab
announcement
in this magazine

TECHNICIANS' NEWS

PLAN TV PROGRAM

Two of Philadelphia's top advertising agencies, with the cooperation of two of the nation's leading parts manufacturers, are preparing the script for a 13-week TV program, to be sponsored by the Philadelphia Council of Radio and Television Service Associations. Cost of props and talent will be paid by the council. The program is designed to promote goodwill between the public and the service industry, and to answer the questions that confront the TV set owner, due to his lack of understanding of the product he purchased and what may be expected from it.

The council is also concerned with another form of advertising—the bait advertising by unscrupulous TV and radio service concerns. Charles Knoell, vice-president of the Television Service Dealers Association reported to the council that his association is preparing an anti-bait advertising bill for presentation to the City Council. T.S.D.A. has been investigating the problem for 6 months. In the same investigation, it has also been looking into other forms of unethical advertising, and has been studying evening and Sunday work by employed service technicians and others operating from private homes and back-alley shops.

AD QUIZ CIRCULATED

The Utah Association of Radio and Television Servicemen has circulated among its membership a questionnaire on advertising practices. Among the questions asked are: What is the best type of advertising in your area (TV, Radio, Newspaper, TV Weekly)? How much do you want to spend on advertising per month? How often should advertising be run? A number of other queries were made. The questionnaire also asked if members favored State or City licensing, and for suggestions as to what qualifications a shop should have to obtain a license.

With the questionnaire, the Utah association put out a two-page mimeographed letter, including a call to the June meeting and a tribute to the officers who had served the Association during its first year.

NEW DETROIT GROUP

The Electronic Service Association, a non-profit organization under the laws of the State of Michigan, has been formed in the Detroit area, according to a report by Robert Aronson of the association's publicity committee. The group is open to anyone engaged in the full-time servicing of radio, television or electronic equipment.

Officers of the association are Ralph L. Carew, president; Joseph Rosson, vice-president; George Sturman, recording secretary; T. T. Czarnecki, corresponding secretary; and Peter Wroblewski, treasurer.

END

BE Sure with **CORNISH**

Wires

Identified with
QUALITY since the swaddling
days of Radio. The era of
Television finds them, more
than ever, the Serviceman's
Friend.

TV LEAD-IN CABLES
ANTENNA CONTROL CABLES
INTERCOMMUNICATION CABLES
COAXIAL CABLES
MICROPHONE CABLES
SHIELDED CABLES
TEST LEAD WIRES
HOOK-UP WIRES
PORTABLE CORDS
REPLACEMENT CORD SETS

CORNISH WIRE COMPANY, INC.
50 Church Street, New York 7, N. Y.

AUDELS TV-RADIO SERVICE LIBRARY

HERE IS LATE INFORMATION IN A
HANDY FORM FOR RADIO AND TELEVISION
REPAIRMEN, SERVICEMEN AND STUDENTS



2 VOLS. \$6 COMPLETE \$1 A
PAY ONLY 1 MO.

AUDELS T.V.-RADIO SERVICE LIBRARY—Highly Endorsed—1001 Facts—Over 1552 Pages—625 Illustrations, Diagrams of Parts. Presents Important Subjects of Modern Radio, Television, Industrial Electronics, F.M., Public Address Systems, Auto, Marine & Aircraft Radio, Phonograph Pick-Ups, etc.

IT PAYS TO KNOW!
The Basic Principles—Construction—Installation—Operation—Repairs—Trouble Shooting. Shows How to get Sharp, Clear T.V. Pictures. Install Aerials—How to Test. Explains Color Systems, Methods of Conversion, Terms, etc. Includes Ultra High Frequency (U.H.F.)—Valuable for Quick Ready Reference & Home Study. Tells How to Solve T.V. & Radio Troubles—Answers Your Questions.

Get this Information for Yourself.
7 DAY TEST—ASK TO SEE IT!

-----MAIL ORDER-----
AUDELS Publishers, 49 W. 23 St., N.Y. 10, N.Y.
Mail AUDELS T. V. RADIO SERVICE LIBRARY 2 Vols. \$6 on 7 days free trial. If O. K. I will remit \$1 in 7 days and \$1 monthly until \$6 is paid. Otherwise I will return them.

Name _____
Address _____
Occupation _____
Employed by _____ RE

Fits Anywhere!



15/16" COMPOSITION-ELEMENT

Series A47 and A47F

1/2 WATT CONTROLS

Choose your key to any replacement need — right size, right ohmage, right taper, right tap, right shaft, right switch — right at your finger tips. Minimum inventory with Clarostat 15/16" Ad-A-Switch* and Pick-A-Shaft* controls (taking attachable switches and shafts) provides for maximum variety of replacements. And all are stocked locally by distributors serving the service trade best. Literature on request.

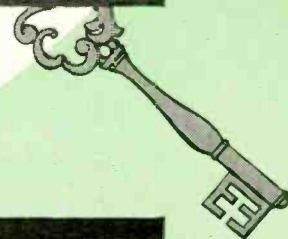
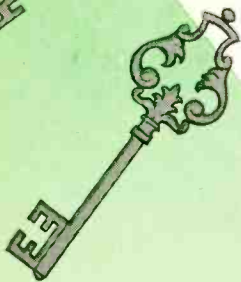
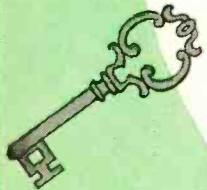
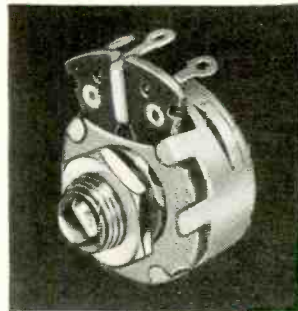

... PLAIN OR TAPPED

The completely redesigned Clarostat 15/16" dia. composition-element 1/2 watt control (Series A47) is small enough to fit into the tightest spots. 500 ohms to 10 megohms. Various tapers. Also tapped (Series A47F) 200 ohms to 2 megohms, with popular selection of taps.

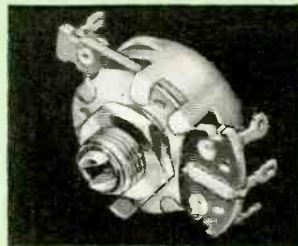

... WITH SWITCH

And the desired switch is easily and quickly attached. Series SWE-12 S.P.S.T. (rated at 5 amps. 125 v.a.c.); Series SWE-20 D.P.S.T. (3 amps. 125 v.a.c.); Series SWE-21 Mod. D.P.S.T. (3 amps. 125 v.a.c./d.c., one-pole-on, one-pole-off, or with jumper for S.P.D.T.). Designed by Clarostat, made by Clarostat, for exclusive Clarostat use. No better switch has yet been offered.

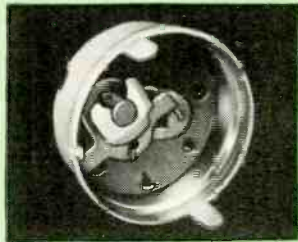

... ANY SHAFT

For the mechanical requirements, choose the correct shaft from the 12 different "Pick-A-Shaft" types, or again the insulated or the high-voltage coupler types. Selected shaft inserts firmly and permanently in the selected control.

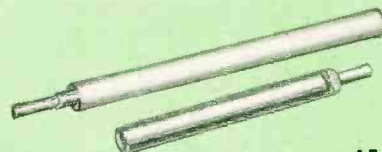

* Trade-mark

CLAROSTAT MFG. CO., INC., DOVER, NEW HAMPSHIRE

In Canada: Canadian Marconi Co., Ltd., Toronto, Ont.

TRANSVISION FIELD STRENGTH METER

*Finest
at
Any Price*



For 110V AC,
and BATTERY
OPERATION

**SAVES 50% OF
INSTALLATION COST**

Works from antenna
(no TV set needed)

FINEST because: Each Meter is individually calibrated in microvolts on every channel. Widest range—10-50,000 microvolts. 12 channel selector. Multiplier switch for weak signal areas.

Pays for itself on 3 or 4 jobs. Measures relative picture signal strengths directly from antenna. Determines best antenna system and orientation. Checks receiver re-radiation (local oscillator). Identifies signals—TV, FM, TVL. Easy to operate. Light, rugged. Many other exclusive features.

*Model FSM-5, for 110V AC only. Complete with tubes.
Wt. 13 lbs. net \$79.

Model FSM-5B, for Battery Operation and 110V AC.
Wt. 13 lbs. net \$89.

TRANSVISION, INC.
NEW ROCHELLE, N. Y.

**\$79
NET***

**A MUST IN
FRINGE AREAS**

**UHF
OR
VHF**

10 DAY TRIAL:
Try these fine instruments for 10 DAYS. Then, if you return them, your cost less 10% (our cost of re-packaging) will be refunded.

COMMUNITY and MASTER TV

Antenna Systems

Transvision offers the Finest System at Lowest Cost of Installation and Maintenance . . . proven in thousands of difficult installations.

A few of the many ADVANTAGES:

- Highest power output allows longest cable runs . . .
- Central system with only 1 point of service . . .
- TV sets from 1 amplifier . . .
- Maximum signal to each set with minimum interference.

FREE: Engineering advice. Send us your problem for quick solution.

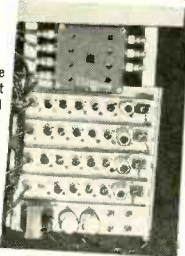

Transvision, Inc., New Rochelle, N. Y., Dept. E8

- Send me _____
- Enclosed find \$_____ deposit. Balance C.O.D.
- My JOBBER is _____
I accept your 10 Day Trial terms.

Name _____
Address _____
City _____ State _____

JOBBER INQUIRIES, INVITED

NEW DESIGN

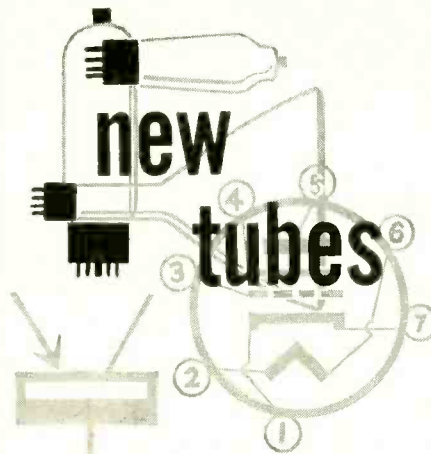

and Transistors

CHROMATIC Television Labs announces the PDF 21-3, a C-R tube for color TV reception. The tube is a direct-view single-gun rectangular-glass-bulb Lawrence type. (See diagram.)

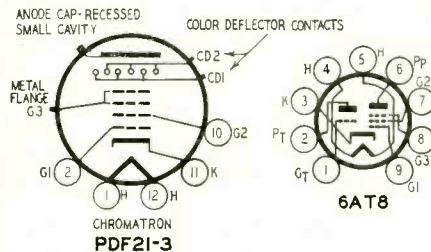

The PDF 21-3 produces a picture size of 14.5 by 11 inches. The single-gun construction provides a bright picture without color fringing when receiving black-and-white or color transmission. The fringe-free pictures are obtained automatically and there is no need for electrical or mechanical convergence equipment or adjustments.

Other design features include low scanning-power requirements, automatic registration, and an anode supply of 18,000 volts, similar to that used in large-screen black-and-white sets.

Sylvania has introduced a new short, 21-inch, all glass, rectangular, aluminumized picture tube, the 21ATP4.

The tube has a gray filter-glass spherical faceplate. It is electrostatically focused and uses magnetic deflection. The deflection angle is 90° and the overall length of the tube is 20 3/8 inches.

Recommended operating conditions for the 21ATP4 are: anode voltage, 16,000; grid 2 voltage, 300; ion trap field strength, 35 gauss. The capacitance between the external conductive coating and anode is 1,500 to 1,800 μf.

RCA has announced the 6AT8, a triode-pentode converter. The multiunit tube is a 9-pin miniature containing a medium-mu triode and a sharp-cutoff pentode. It is designed for use as a combined oscillator and mixer in television receivers using an intermediate frequency in the 40-mc range.

The 6AT8 has the same electrode structure as the 6X8 but has a different



THE NEW PRECISION MODEL 120

**GIVES YOU WHAT YOU WANTED
IN A
HIGH SENSITIVITY
MULTI-RANGE TEST SET**

**20,000 OHMS PER VOLT D.C.
5,000 OHMS PER VOLT A.C.**

The '120' gives you . . .

- ✓ MORE RANGES
- ✓ AN EXTRA-LOW RESISTANCE RANGE
- ✓ AN EXTRA-LOW VOLTAGE RANGE
- ✓ AN EXTENDED LOW CURRENT RANGE
- ✓ A LARGER METER SCALE FACE
- ✓ SIMPLE, POSITIVE RANGE SELECTION
- ✓ POSITIVE CONTACT JACKS and PLUGS

Compare These Wide Spread Ranges and Special Features:

- ★ 8 DC VOLTAGE RANGES: 20,000 ohms per volt.
- ★ 8 AC VOLTAGE RANGES: 5,000 ohms per volt. 0-1.2-3-12-60-300-600-1200-6000 volts.
- ★ 8 AC OUTPUT RANGES: same as AC volt ranges. Built-in 600 volt blocking capacitor.
- ★ 7 DC CURRENT RANGES: 0-60-300 Microamperes. 0-1.2-12-120-600 Ma. 0-12 Amperes.
- ★ 5 RESISTANCE RANGES: self-contained. 0-200-2000-200,000 ohms. 0-2-20 megohms.
- ★ 8 DECIBEL RANGES: -20 DB to +77DB. 0 DB = 1 Milliwatt, 600 ohms.
- ★ EXTRA LARGE 5 1/4" RUGGED 'PAGE' METER: 40 microamperes sensitivity, 2% accuracy.
- ★ 1% MULTIPLIERS and SHUNTS: Wire-wound and deposited film types.
- ★ TWO JACKS SERVE ALL STANDARD RANGES: Separately identified and isolated jacks provide for extra high ranges.
- ★ "TRANSIT" SAFETY POSITION on range selector protects meter during transport and storage.
- ★ CUSTOM-MOLDED PHENOLIC CASE and PANEL: Compact, laboratory-styled instrument.

MODEL 120 . . . complete with internal ohmmeter batteries, banana-plug test leads and detailed operating manual. Overall case dimensions, 5 3/8 x 7 x 3 1/8" Net Price \$39.95

PRECISION APPARATUS CO., INC.

92-27 Horace Harding Blvd., Elmhurst, L. I., N. Y.

Export: 458 Broadway, New York 13, U. S. A.
Canada: Atlas Radio Corp., Ltd., 560 King St., W., Toronto, 2B

Windsor

RADIO & TV
RECEIVING

TUBES

**GUARANTEED
ONE FULL YEAR**

**... FOR PEAK
PERFORMANCE!**



Type	Each	Type	Each
OA2	.88	IR4	.85
OB2	.88	IR5	.62
OC3	.95	IS4	.67
IA7GT	.67	IS5	.52
IAE4	.90	IT4	.62
IB3GT	.69	IU4	.61
IH5GT	.51	IU5	.51
IJ6	.93	IV2	.45
IL4	.63	IX2A	.74
IL6	.66	2X2	1.43
ILA4	.82	3A5	.90
ILA6	.80	3LF4	.76
ILB4	.82	3Q4	.66
ILC5	.80	3Q5GT	.72
ILC6	.80	3S4	.61
ILD5	.80	3V4	.62
ILE3	.80	5R4GY	1.00
ILG5	.80	5U4G	.44
ILH4	.80	5V4G	.83
ILN5	.80	5Y3G	.37
IN34	.90	5Y3GT	.32
IN48	.50	5Y4G	.43
IN5GT	.63	6A8GT	.68
IN64	.75	6AB4	.51

Thousands of Service Organizations and Dealers send us REPEAT orders month after month—they KNOW you can DEPEND on the WINDSOR promise of PEAK PERFORMANCE! Every tube we ship is first carefully tested in our labs, right in a radio or TV set, under actual operating conditions. Each WINDSOR tube is attractively packaged in the famous WINDSOR cartoon tin, has gained consumer acceptance throughout America. BUY—and SELL—WINDSOR TUBES, WITH CONFIDENCE!

Type	Each	Type	Each	Type	Each	Type	Each
6AC5GT	.82	6BF5	.66	6Q7GT	.55	7A4/XXL	.57
6AC7	.90	6BF6	.43	6R7	.75	7A5	.70
6AF4	1.10	6BG6G	1.47	6S4	.51	7A6	.57
6AG5	.59	6BH6	.63	6S8GT	.75	7A7	.58
6AH4	.68	6BJ6	.53	6SA7GT	.56	7A8	.70
6AH6	.89	6BK5	.76	6SC7	.63	7AD7	1.05
6AK5	1.05	6BK7	.97	6SD7	.63	7AF7	.63
6AL5	.44	6BL7GT	.94	6SF5GT	.66	7AG7	.65
6AN8	.95	6BN6	.98	6SG7	.55	7AH7	.65
6AQ5	.51	6BO6GT	.98	6SH7GT	.52	7AJ7	.70
6AQ6	.47	6BQ7	.92	6SJ7GT	.52	7B4	.54
6AQ7	.75	6BY5G	.85	6SK7GT	.55	7B5	.51
6AR5	.42	6BZ7	1.09	6SL7GT	.68	7B6	.52
6AS5	.55	6C4	.41	6SN7GT	.59	7B7	.58
6AS7G	4.50	6C5GT	.60	6SQ7GT	.46	7C4	1.05
6AT6	.42	6CB6	.58	6T8	.85	7C5	.56
6AU5GT	.85	6CD6G	2.04	6U4GT	.60	7C6	.50
6AU6	.47	6D6	.63	6U5	.72	7C7	.58
6AV5	.85	6E5	.72	6U8	.86	7E5	.85
6AV6	.41	6F5GT	.54	6V3	1.09	7E6	.65
6AX4	.72	6H6GT	.55	6V6GT	.51	7E7	.85
6B8G	.93	6J5GT	.44	6W4GT	.50	7F7	.69
6BA6	.50	6J6	.68	6W6GT	.63	7F8	.97
6BA7	.66	6J7	.70	6X4	.37	7G7	.85
6BC5	.58	6K6GT	.45	6X5GT	.36	7H7	.61
6BD5GT	.98	6K7	.70	6X8	.82	7J7	.85
6BD6	.54	6L6G	.88	6Y6G	.64	7K7	.85
6BE6	.51	6L6GA	.88	6ZY5	.60	7L7	.85

Type	Each	Type	Each
12B7Y	.77	25A5V	.85
12J5GT	.48	25BQ6GT	.98
12SA7GT	.57	25L6GT	.53
12SH7GT	.67	25W4GT	.53
12SK7GT	.55	25Z6GT	.46
12SL7GT	.67	35A5	.55
12SQ7GT	.59	35B5	.53
12S7GT	.46	35C5	.53
12V6	.51	35L6GT	.52
14A7	.58	35W4	.33
14AF7	.68	35Y4	.48
14B6	.50	35Z3	.48
14C5	.75	35Z5GT	.33
14C7	.80	50A5	.55
14E7	.85	50B5	.52
14F7	.69	50C5	.52
14F8	.99	50L6GT	.52
14J7	.85	50X6	.55
14N7	.75	1172GT	.43
14Q7	.62	11726GT	.75
14R7	.85		
14S7	.80		
19B6G	1.53		
19T8	.87		

WINDSOR "WONDER-BEAM" 3-WAY TV ANTENNA

For Average Areas, Fringe Areas and UHF, Adjustable arms, and new electronic wonder-switch for optimum performance with any TV set!

SPECIAL PRICE \$5.69 each
Lots of Six Singly \$5.95 each

FREE! WINDSOR TUBE CADDY

Most Practical service-aid ever designed for Radio & TV repairmen! Now offered FREE with every purchase of \$100.00 or accumulated purchases totalling \$100.00 within 90 days. (You get Caddy credit memo with each purchase).

- Carries approximately 125 tubes including meters and tools.
- 13 1/4" Long, 8 3/4" Wide, 13 3/4" High. Weighs only 9 lbs.
- Ruggedly constructed with heavy leatherette covering, strong plastic handle, nickel plated hardware, and reinforced with metal clamps.

WINDSOR TUBE CADDY MAY ALSO BE PURCHASED OUTRIGHT FOR \$14.95.

WINDSOR "BROW-LITE"

LEAVE BOTH HANDS FREE TO WORK!

World's most useful flashlight! Ideal for Radio & TV Repairmen. Uses standard penlite batteries and bulb. Won't interfere with glasses, rides above them over the brow. Complete with Batteries..... **\$4.95**

25% Deposit with Order. All merchandise F.O.B. NYC. For orders less than \$10, add \$1 handling cost. Deduct 2% if full remittance accompanies order. All merchandise subject to prior sale and price changes without notice.

Windsor ELECTRONIC TUBE CO.
2612-C NOSTRAND AVENUE, BROOKLYN 10, N. Y.

Write for Additional Tube Types and Prices. We also stock Special Purpose and Transmitting Tubes at Similar Savings! Dept. C-8

HI-FI FANS—

SPECIAL FOR YOU—two books to help you get better performance from your high-fidelity equipment.

High-Fidelity Techniques

128 Pages
Over 100 Illustrations.
\$1.50

High-Fidelity Measurements

112 Pages, Illustrated
\$1.00

High-Fidelity -- Design, Construction, Measurements

For the real audio fan! Assume you know fundamentals and from these outlines practical methods for working toward perfection in a hi-fi system. Unique 3-way approach covers hi-fi from standpoint of design, construction and measurements.

See coupon on page 114

GERNSBACK PUBLICATIONS, INC.
25 West Broadway New York 7, N.Y.
Publishers of RADIO-ELECTRONICS

DON'T YANK OR INSTALL A FLYBACK OR YOKE—TILL YOU CHECK IT WITH THE 944!

PLAY IT SAFE

BE SURE! SAVE TIME!

NEW! EICO 944 FLYBACK TRANSFORMER & YOKE TESTER KIT \$23.95. WIRED \$34.95.

A time—and trouble-saving MUST for TV servicemen!

- Positive check of all flybacks & yokes, in or out of set—fast!
- Uses sensitive grid-dip principle—detects even 1 shorted turn!
- Exclusive separate calibration for air- & iron-core flybacks assures utmost accuracy.
- Checks any inductance of not too low impedance; also usable for general continuity testing.
- Large 4 1/2" 50 ua meter, 3 separate "Good-Bad" scales.

BUY EICO—at your local jobber—and SAVE 50%. Write now for FREE Catalog CF-8

ELECTRONIC INSTRUMENT CO., Inc.
84 Withers Street • Brooklyn 11, N. Y.

NOW!



COLOR TV COVERAGE IN PHOTOFACT!

FIRST COLOR TV FOLDER

the **RCA Model CT-100**
OVER 40 FACT-PACKED PAGES

It's a terrific **FIRST**—complete data based on actual analysis of the production model...full schematics, block diagrams, parts lists, tube placement, alignment, wave forms, set-up adjustments—*everything* you want to know about this actual color set—information you want and need to get out in front on Color TV!

here's how to get it!

- 1** Included with Photofact Folder Set No. 252—out Sept. 1st. You get it in *addition* to over 100 pages of regular Photofact TV-Radio coverage. Get the Color TV Folder at the regular price of the complete Set...Only \$1.75!
- 2** You can buy the Color TV Folder separately if you wish. Available from your distributor for only \$1.00!

GET IT EITHER WAY FROM YOUR PARTS DISTRIBUTOR

RESERVE YOUR COLOR TV FOLDER TODAY!

NEW DESIGN

basing arrangement to permit shorter connections to the coils in the various designs of turret tuners. Except for a very slight change in some of the inter-electrode capacitances, the characteristics and ratings of the 6AT8 are the same as for the 6X8. The basing arrangement is shown in the diagram.

A phototube electronically "allergic" to spots before its "eyes" has been announced by RCA. Designed for production-line inspection of soft-drinks, medical solutions, and similar translucent liquids, the light-sensitive tube reacts to even minute, transparent impurities.

The phototube, the 6405/1640, has a high sensitivity to red and near-infrared radiant energy and is especially useful with an incandescent light source.

The 6405 has a non-hygroscopic base that maintains a high resistance between anode and cathode. As a result, more output for a given light input is obtainable under high-humidity conditions.

An interesting RCA development is the 5AUP24, a 5-inch C-R tube designed for use as the flying-spot scanner in a color video-signal generator. Color television signals may be generated by scanning Kodachrome slides or similar transparencies.

This new tube features a metal-backed phosphor with a spectral-energy emission characteristic peaked in the blue-green region and with sufficient range to provide usable energy over the visible spectrum for generating color signals from color transparencies. Because of the extremely short persistence of the phosphor, very little equalization is needed to minimize blurring or trailing in the reproduced picture; hence the signal-to-noise ratio is good.

The tube face is made of a special, non-darkening glass, and has an optical quality that will not limit the performance of a high-quality objective lens needed to provide maximum resolution.

Other features of the 5AUP24 include a high-resolution gun of the electrostatic-focus type; 40° deflection angle to minimize defocusing and provide high corner resolution; an external conductive coating on the neck that, when grounded, prevents corona between the yoke and neck; a built-in capacitance to serve as a supplementary filter capacitor; and an external insulating coating on the bulb cone to minimize sparking over the bulb during conditions of high humidity. The maximum anode rating for the 5AUP24 is 27,000 volts.

Radio Receptor Co. has announced a new miniature p-n-p photo transistor, type RR66. It was developed for use in automobile headlight dimmers, but is equally useful in a large variety of industrial equipment.

The light-sensitive element is hermetically sealed in a glass bulb and is connected to three leads that emerge from a glass header. The spectral response covers the visible range and extends far

SUPER TV BARGAINS



UHF CORNER REFLECTOR
ONLY \$2.99 EACH IN LOTS OF 6
SINGLE LOTS \$3.50 EACH

This hi-gain UHF Corner Reflector can only be offered you at this low, low price for a short time. 8 to 11 db gain across UHF band. Order Model F-G.



Tremendous Conical Bargain
2-Bay 16-Element Array
\$4.99 EACH IN LOTS OF 3

With Hi-Band Adapters. Sturdy 3/4" Elements. SINGLE LOTS EACH \$5.30
This conical 2-bay 16-element array provides ultra-fine fringe reception. Includes sixteen 3/8 inch airplane type aluminum elements, including hi-band adapters for greater gain on the high channels and is complete with one pair of stacking bars to each array. These are packed in cartons of three 16-element arrays per carton, with tie rods, at \$14.95 per carton. Single 16-element arrays, separately boxed—your cost \$5.30 each. 3 Two-Bay Arrays per carton with-out Tie Rods, \$13.50 carton. 4 Bay Ultra-Fringe Stacking Assembly for Above—Model 4B, \$19.95 set.

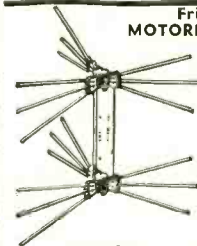

Fringe Master
MOTORLESS DIRECTRONIC
• NO GHOSTS
• NO INTERFERENCE
• ELECTRONICALLY BEAMED
• NO MOTORS NEEDED

Model AX-599, 18-element, stacked array provides sparkling reception in city or fringe—all channels in all directions. Serviceman's kit provides 18 hi-tensil aluminum elements, 8-position Directronic Beam Selector, 1 set matched stacking bars, 75" TR-1 Cable, universal U-Clamp. Complete Kit...\$16.95

\$16.95

NEW SPRING-SUMMER CATALOG AVAILABLE

ALL PRICES F.O.B. CLEVELAND, OHIO
Do not remit more than complete purchase price. Pay shipping charges on receipt of goods. 25% deposit on all C.O.D. orders, please. Money-back guaranteed.

National Electronics
OF CLEVELAND
THE HOUSE OF TV VALUES

208 Delco Bldg. Cleveland 3, Ohio

ENJOY 3 COLOR TELEVISION FILTER SCREEN NOW

Changes dull eye-straining black and white pictures into beautiful color tones. Seconds to attach. No tools used. Helps eliminate glare and snow in fringe areas. Order direct. Send \$1 for screen size up to 16", \$1.25 size 17", \$1.50 size 20", \$2 size 21", \$2.50 size 24", \$3 size 27". (Also available are single solid color screens in blue, green, or amber.) Prices on solid color screens are 10% less. We pay postage except on C.O.D. orders. Satisfaction guaranteed. Inquiries from dealers also welcomed.
Zingo Products, Johnstown 13, New York



Only from famous COYNE do you get this modern up-to-the-minute TV Home Training. Easy to follow, Step-by-Step instructions—fully illustrated with 2150 photos and diagrams. Not an old Radio Course with Television tacked on. Personal guidance by Coyne Staff. So practical you can quickly EARN MONEY IN A TV-RADIO SALES AND SERVICE BUSINESS—part time or full time. Not only FINEST TRAINING but COSTS MUCH LESS—pay only for training—no costly extras.
SEND COUPON FOR DETAILS FREE
SEND COUPON BELOW for Picture Folder and full details including EASY PAYMENT PLAN. NO COST OR OBLIGATION—NO SALESMAN WILL CALL.

B. W. COOKE, Pres. **COYNE ELECTRICAL SCHOOL** FOUNDED 1899

A TECHNICAL TRADE INSTITUTE CHARTERED NOT FOR PROFIT
500 S. Paulina Dept. C4-HT4 Chicago 12, Illinois

B. W. COOKE, President
COYNE ELECTRICAL SCHOOL
500 S. Paulina St., Chicago 12, Ill., Dept. C4-HT4
Send FREE Picture Folder and details of your Television-Radio-Electronics Home Training offer.

Name.....
Address.....
City..... State.....

NEW DESIGN

into the infra-red so that it is especially useful in black-light applications.

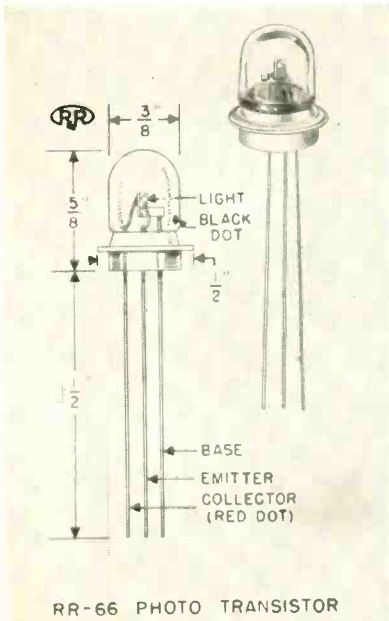

RR-66 PHOTO TRANSISTOR

An 8-ounce "flyweight" power triode designed for airborne communications, with high-power output at ultra-high frequencies was announced by RCA.

The new tube, the 6383, has a maximum plate dissipation of 600 watts and can be operated with full plate voltage and plate input at frequencies up to 2,000 mc.

The u.h.f. triode is designed for both liquid and forced-air cooling to provide maximum efficiency at high altitudes. Under normal temperature and atmospheric conditions, the tube can be cooled with distilled water. In the water-freezing cold and rarefied air of high altitudes, the tube can be cooled efficiently with chemical coolants.

The "flyweight" power triode features a coaxial-electrode structure for use with circuits of the coaxial-cylinder type. This structure permits effective isolation of the plate from the cathode, and makes the tube particularly suitable for cathode-drive circuits. **END**

Radio Thirty-Five Years Ago

In Gernsback Publications

HUGO GERNSBACK Founder

Modern Electrics	1908
Wireless Association of America	1908
Electrical Experimenter	1913
Radio News	1919
Science & Invention	1920
Television	1927
Radio-Craft	1929
Short-Wave Craft	1930
Television News	1931

Some of the larger libraries still have copies of ELECTRICAL EXPERIMENTER on file for interested readers.

35 YEARS AGO IN THE AUGUST 1920 ISSUE OF SCIENCE AND INVENTION (ELECTRICAL EXPERIMENTER)

New York University Field Radio
Wireless Telephony on Shipboard
A War-Time Radio-Detective, by Pierre H. Boucheron
Magnavox Boosts Radio Signals

AUGUST, 1954

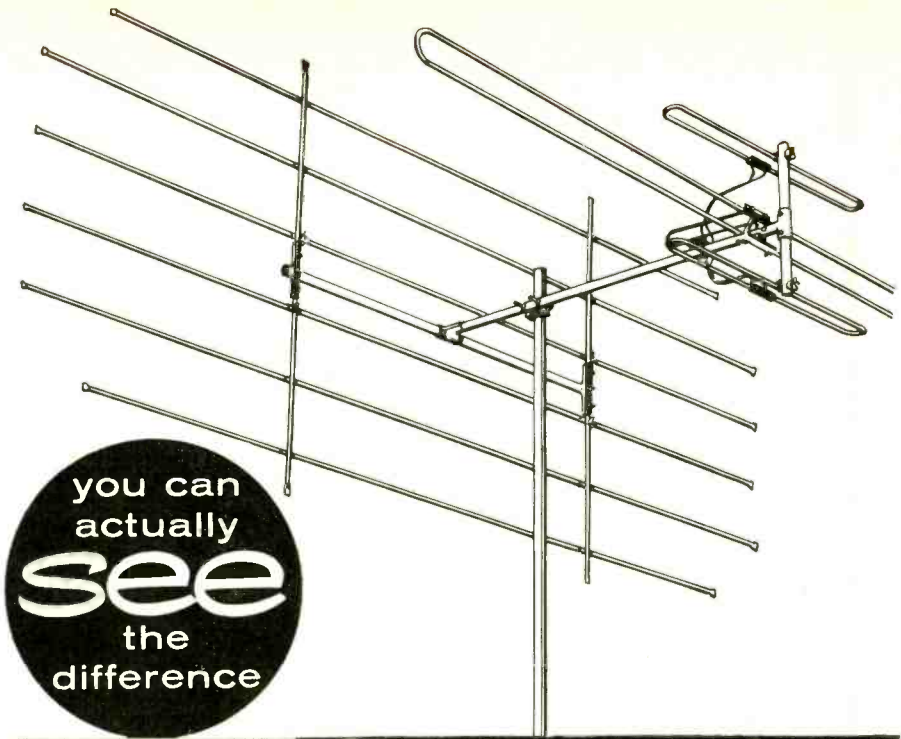

with the

C-D Skyhawk
ULTAMATIC
All Channel TV Antenna

NOW... C-D designs the finest TV Antenna... the first antenna with which you can actually SEE the difference! Perfectly synchronized for monochrome and COLOR TV. The most uniform gain response that does not vary more than 3 D.B. on any channel across the band. Other features include low voltage standing wave ratio... higher front-to-back ratio... speedy assembly... aluminum screen reflector... dipole and boom of heavy gauge, seamless tubing.



Consistently Dependable
CORNELL-DUBILER
SOUTH PLAINFIELD, N. J.



CAPACITORS · ANTENNAS · ROTORS · VIBRATORS · CONVERTERS

OVER 50,000
TECHNICIANS
HAVE LEARNED

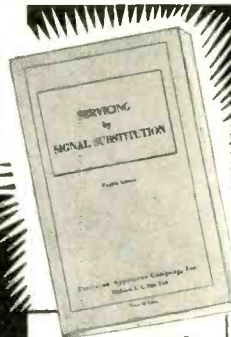

**'SERVICING BY
SIGNAL SUBSTITUTION'**
A BEST SELLER FOR OVER 12 YEARS!
(NEW, UP-TO-DATE, 12th EDITION)

HOW TO GET
THE MOST OUT
OF BASIC TEST
EQUIPMENT

for A.M. - F.M. - TV

ONLY **40¢**
103 pages. Invaluable information that will help you re-double the value of your basic test equipment.

The Modern, Simplified, Dynamic Approach to Receiver Adjustment & Alignment Problems.

- ★ Nothing complicated to learn
- ★ No extra equipment to purchase
- ★ Universal... non-obsolete
- ★ Employs only Basic Test Instruments

Ask for "S.S.S." at your local Radio Parts Jobber or remit 40¢ in small stamps or coin directly to factory.

PRECISION APPARATUS COMPANY, INC.
92-27 HORACE HARDING BLVD., ELMHURST 4, N. Y.

**FOR THE FINEST
SOUND SYSTEMS**

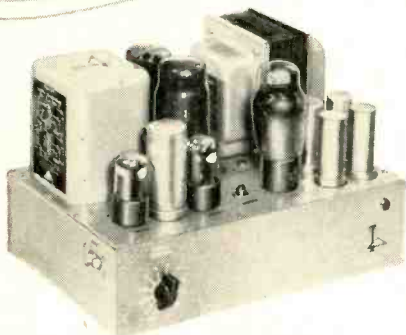

TRIAD High Fidelity Amplifier Kits

A home music system which will meet true high fidelity standards must necessarily be composed of the very finest components — pickups, turntables, amplifiers, speakers, enclosures.

In this group of components Triad offers High Fidelity Amplifier Kits — built by men with a brilliant background in producing America's finest transformers. Engineered to produce maximum frequency range with minimum distortion, these "do-it-yourself" kits afford obvious economies over complete units — which permits upgrading of other components in the system.

Triad High Fidelity Amplifier Kits include all necessary transformers and chokes, punched sectional aluminum chassis and complete assembly instructions.

In quality and performance they are fitting companions to the finest sound system components available today.

HF-3 Kit: Pre-amplifier. Adequate gain to drive an HF-40 or HF-18 from any commercial pickup or microphone. D.C. filament supply. Complete record compensation and new tone control circuits. List Price — \$32.80.

HF-12 Kit: 10-watt power amplifier. Replaces HF-10. Built-in preamp to accommodate all crystal and magnetic cartridges. Complete record compensation and new tone control circuits. Output impedances 4-8-16 ohms or 125-250-500 ohms. List Prices from — \$50.40.

HF-18 Kit: "Williamson" type all-triode amplifier. Full power output of 16.2 watts for triode operation or 20 watts for pentode operation from 12 to 60,000 cycles. Frequency response within 0.2 db from 7 to 80 kc. Output impedances 4-8-16 ohms or 125-250-500 ohms. List prices from — \$63.65.

HF-40 Kit: Features a full 40-watt amplifier from 20 to 40,000 cycles, using regulated screen voltage and fixed bias on two 6146 output tubes. Output impedances 4-8-16 ohms or 125-250-500 ohms. List from — \$78.35.



4055 Redwood Ave. • Venice, Calif.

Write for
Catalog
TR-54B



NEW PATENTS

SUBAUDIO TRANSMISSION

Patent No. 2,670,460

Roswell W. Gilbert, Montclair, N.J.
(assigned to Weston Electric Instrument Corp.)

Radio signals can be transmitted easily on an a.c. power line. Hams, engineers, and experimenters have used such lines to carry speech, generally on a carrier frequency of about 100 kc. At this high frequency line losses are likely to be high, due to unpredictable capacitance to ground and other conductors. If control signals only are to be transmitted, a very low frequency (for example 0.1 to 10 cycles) is more efficient. These low frequencies introduce the problem of designing suitable filters so that several frequencies may be transmitted at the same time. A 50-henry coil wound for a Q of 50 (at 1 cycle) would weigh hundreds of pounds. This inventor solves the problem. He shows how to design a very-low-frequency filter using ordinary d'Arson-

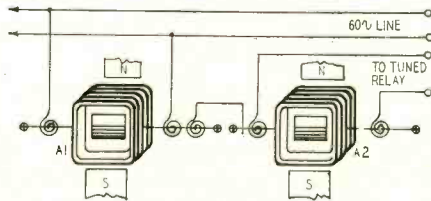

Fig. 1

val-type moving coils.

A pair of moving-coil assemblies, A1 and A2, whose natural frequencies are f_1 and f_2 respectively are shown in Fig. 1. These frequencies differ slightly, but both are approximately the same as the frequency to be transmitted over the lines. A1 is connected across the power line as shown. It is coupled to A2 through a spiral spring. A1, A2 are the mechanical equivalent of a pair of coupled coils. With sufficient coupling, this network will have a frequency response like that shown in Fig. 2. If the carrier signal is approximately f_1 or f_2 , the coils will go into vibration. The steep sides of the curve show that when the carrier frequency is outside this range, there will be no response.

A1 acts as a motor which vibrates when the coil is excited by the line signal. A2 acts like a generator and supplies current when its coil vibrates between the magnet poles. This output energizes a relay tuned to a frequency between f_1 and f_2 .

The bandpass response has two advantages over that of a conventional resonance curve. The wider band means that tuning will not be critical

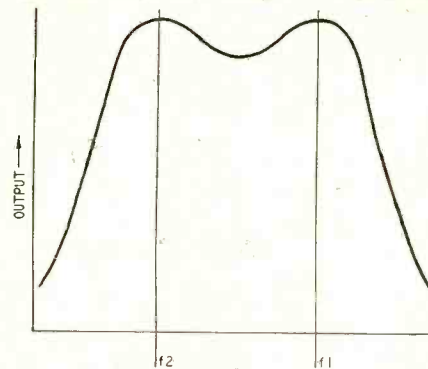

Fig. 2

either at the transmitter or receiver. The bandpass curve has steeper sides, so selectivity is higher. Thus there is room for more signals to be transmitted over the same line without interference.

CONTINUITY TESTER

Patent No. 2,677,100

Bud R. Hayhurst, Auburn, Wash.
(assigned to Boeing Airplane Co.)

This instrument tests fuses without removing them from the circuit or even shutting off the power. A buzzer creates a local magnetic field. This field cuts the fuse (if it is not burned out) and induces a.c., which is measured.

When SW is closed the buzzer chops the battery current, creating a.c. across L. The a.c. is fed to the potentiometer. Equal and opposite current flows through each half of the trans-

EDLIE "SAVE
says

ON 3-WAY Portable Kits"
and other KITS and WIRED UNITS



**3-Way
Portable
RADIO
KIT
AC/DC
Batteries**

NEW, compact, lightweight portable radio kit with the very latest supersensitive superhet. circuit. Wonderful reception from either batteries, or 115 V., 50-60 cycle AC or DC. Includes all complete parts (except wire & solder) necessary to build a great sounding radio.

Also includes circuit diagrams and simplified, complete step-by-step instruction folder which makes assembling easy. Housed in a beautifully high-glossed Catalin cabinet in two delightful and distinctive colors: maroon or alabaster (ivory). Size: 9 1/2" x 5 7/8" x 4 3/4". Includes tubes!

\$13.95
(maroon or ivory)

TERRIFIC VALUE!

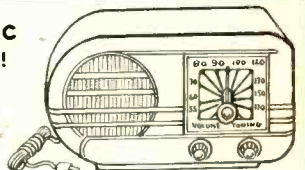

5 TUBE AC/DC Superhet Kit

Kit #1: 5 tube superhet kit. AC/DC includes all quality components required to construct this latest design, highly sensitive superhet broadcast receiver, complete with black, glistening bakelite cabinet (excludes wire & solder). Kit of 5 tubes. 12AT6, 2/12-BA6, 12BE6, 35W4, 6DB5.

Price, Less Tubes..... **\$7.95**
Extra for Tubes..... **\$3.25**

Great Savings!

6-TUBE RADIO KIT

Kit #2: Low priced 6-tube kit designed for extra high sensitivity, excellent selectivity and good, rich tone quality. Uses 45L6, 25Z6, 6XQ7, 6SA7, 2/6X17 in an easily constructed circuit. Includes all parts: punched chassis, resistors, condensers, coils, sockets, PM speaker, hardware, etc.

Special closeout price. (Less tubes & cabinet)..... **\$6.95**
Matched set of 6 tubes for kit..... **\$3.25**

3 TUBE PHONO AMPLIFIER

NOT A KIT

An assembled unit ready for installation using tone and volume control and 6 ft. rubber cord. (less tubes) **\$2.95**

Lowest Price!
With complete set of tubes..... **\$4.45**

Phono Oscillator

NEW SAVINGS! NOT A KIT!

Wireless phono oscillator transmits recording for crystal pickups or voice from carbon mike through radio without wires. Can also be used as an intercom by using PM speaker as mike (less tubes) **\$2.95**

With complete set of tubes..... **\$3.95**

PRECISION RESISTOR KIT

Consists of 50-1% Wilkor carbonfilm resistors of 50 different ohmages housed in a transparent plastic box. May be combined in series or parallel to produce almost any desired ohmage. Each resistor retails for about \$35.

Terrific Cash Saver! **\$2.45**

Kit of 50 **only \$2.45**

TERMS: All items shipped FOB New York City, prices subject to change without notice. Include 20% deposit for C.O.D.'s. **WRITE TODAY FOR NEW FREE CATALOG!**

EDLIE Electronics

154 Greenwich Street
New York 6, New York
DI 9-3143

The Complete Line



Aptitude-Tested
ELECTRONIC
WIRES
and
CABLES

Belden makes a complete line of Aptitude-Tested electronic wires and cables. You can select the right wire for every application, because all performance values are shown. See your Belden Catalog.

Belden Manufacturing Company
Chicago, Illinois

Belden

**WIREMAKER
FOR INDUSTRY**



The Complete Line of Quality Phonomotors



Model SS
3-speed, 2-pole motor



Model DSS
3-speed, 4-pole motor



Model DR
2-speed, 4-pole motor

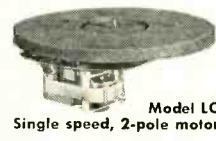

Model LC
Single speed, 2-pole motor



Model RM4
Single speed,
4-pole motor



Model D-10
4-pole motor widely used
for tape recorders

- FOR PORTABLE PHONOS
- FOR HI-FI UNITS
- FOR COMBINATIONS
- FOR RECORD CHANGERS
- FOR TAPE RECORDERS
- FOR REPLACEMENT USE
- FOR EVERY PHONO APPLICATION

Whatever your phonomotor or tape recorder requirements, you'll find the *exact* answer in the famous *Smooth Power* line of single-speed, dual-speed and three-speed motors. Illustrated at the left are just a few of the many different types from which to choose.

Each of these advanced design motors incorporates General Industries' exclusive engineering and construction features which assure trouble-free performance and long-lasting dependability.

Complete information, including dimensions, specifications and quantity quotations, furnished promptly upon request. Write to:

THE GENERAL INDUSTRIES CO.
DEPARTMENT ME • ELYRIA, OHIO

Grand Opening Specials Top Quality Parts—Fully Guaranteed P M Speakers

5" with O.P. Transformer.....	\$1.85
5 1/4" Heavy Slug.....	1.75
6" x 9" Oval.....	2.99
12" Good Bass Response.....	5.95
Selenium Rectifiers—Known by Color	
65 Ma..... \$.65	300 Ma..... \$1.59
100 Ma..... .85	450 Ma..... 1.95
6 ft. cord sets, Ivory or Brown.....	.24
6 ft. cheater cord sets.....	.29
25 ass't. 10W WW Res.....	2.29
C-H SA 125V SPST Toggle Sw. Bat Handle.....	.24

All purchases of \$5 or more sent prepaid.
Send for our value packed catalog!

Penman Electronics

140 East 5th St. St. Paul, Minnesota

RADIO • TELEVISION SERVICEMEN!

HERE IS YOUR 1954 OPPORTUNITY
TO DEVELOP A PROFITABLE
SMALL APPLIANCE REPAIR SERVICE
WITH PRESENT SHOP EQUIPMENT

We supply a complete program designed
to maintain you in the highly profitable
traffic appliance repair field.

ELECTRIC SWEEPER SERVICE CO.

"The House of **ESSCO** 100,000 Parts"

2034 EUCLID AVE. • CLEVELAND 15, OHIO

NEW PATENTS

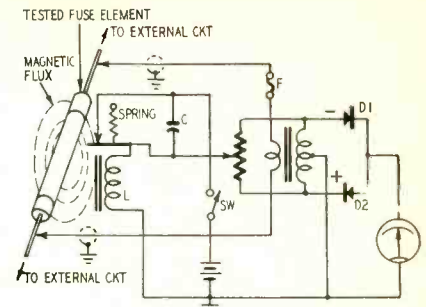

former secondary, returning through its center tap to ground. Due to cancellation, no current is indicated at the meter.

If the fuse is not blown, a.c. is induced in it and current flows through the primary winding. Current is transferred to the secondary and since this flows in one direction it unbalances the condition described above. D1 and D2 rectify the a.c. and current is indicated at the meter. Any d.c. in the fuse circuit cannot possibly effect the test.

Should the tested fuse element be blown out or otherwise defective, so that it does not form a continuous conductor, the only voltage applied to the selenium rectifiers is the reference voltage, and the meter current will be zero.

A protective device F is included to guard against possible damage due to high voltage in the tested circuit. C is used to minimize sparking across buzzer contacts.

SMOOTHING NETWORK

Patent No. 2,677,054

Sidney B. Cohen, Brooklyn, N.Y.
(assigned to Sperry Corporation)

This network uses no tuned filters. It suppresses rapid fluctuations of signal, while passing slower changes, thus making it useful in servo systems. As shown in Fig. 1, E_{IN} , the a.c. signal, is in series with resistor R. While the signal remains steady, so does the output, E_{OUT} . When E_{IN} varies, however, the impedance Z_{IN} (reflected) varies and controls the output signal. E_{OUT} is always a smoothed-out version of the input, since Z_{IN} varies inversely as the rate of signal change.

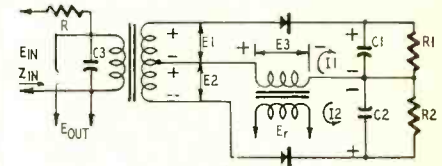

Fig. 1

In Fig. 1, E_r is an external signal at the same frequency as E_{IN} (for example, 400 cycles). It induces a reference voltage E_3 . Two other voltages, E_1 and E_2 , exist only when the signal varies. E_3 is the largest of the 3 voltages so it controls conduction of the rectifiers. Conduction is possible only when E_3 has the polarity indicated. The polarity of E_1 and E_2 depends upon the signal. When E_{IN} increases, their polarity is as shown. It is reversed when the signal amplitude drops.

The secondary circuit is a phase detector which passes current only in the direction of the arrows (I1, I2). Therefore C1 and C2 can only charge through the rectifiers. Discharge must take place through R1 or R2. The capacitors charge to an average value, E_3 , when the signal is steady (while E_1 and E_2 are zero).

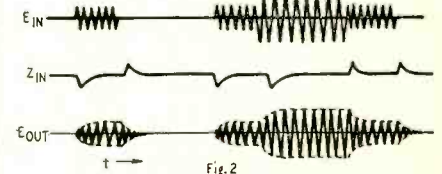

Fig. 2

Assume a signal increase. E_1 and E_2 are induced as shown. E_1 adds to E_3 and I1 begins to charge C1. Since E_2 subtracts from E_3 , C2 discharges from its voltage value E_3 through R2. The only current through the transformer secondary is I1. It creates a flux which opposes that of the primary. Thus the effective inductance of

**Do a Lot...
With
a Little**



*Cover 75% of Your Replacement Needs
with Just 6 Mallory Vibrators*

You don't need a large inventory when you rely on Mallory Vibrators for your replacement work. A selection of just six Mallory Vibrators gives you coverage of 75% of your jobs.

And you can use Mallory Vibrators with complete confidence that their performance will satisfy you . . . and your customers. Mallory not only made the first commercial vibrator but supplies more to set makers than all other manufacturers combined.



Do It Faster...

You speed selection of the right Vibrator for any job when you use the current Mallory Vibrator Guide. It's your complete cross-reference and service guide. See your Mallory Distributor about this handy book . . . or write P.O. Box 1558, Indianapolis 6, Indiana.

P. R. MALLORY & CO. Inc.
MALLORY

CAPACITORS • CONTROLS • VIBRATORS • SWITCHES • RESISTORS
RECTIFIERS • POWER SUPPLIES • FILTERS • MERCURY BATTERIES
APPROVED PRECISION PRODUCTS

P. R. MALLORY & CO. Inc., INDIANAPOLIS 6, INDIANA

THE *American* IDEA

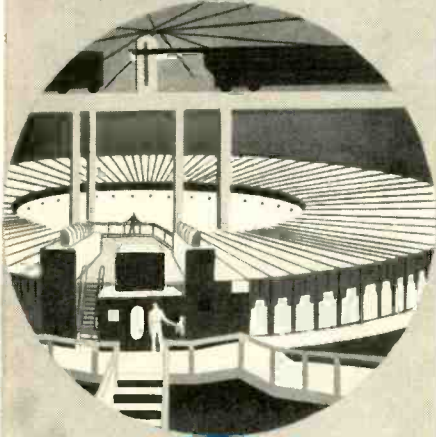

"To find and follow the better way"... Gigantic offspring of the cyclotron, the Bevatron—world's greatest magnet—can send masses of protons hurtling around its 135'-diameter race track at almost the speed of light. "Idea", to penetrate deep into the atomic nucleus, where lie secrets of matter and energy.

With us, the "American Idea" is, by directed effort and applied know-how, to continue to lead in bringing you electronic products of the highest quality.



Replacement Phonograph Cartridges

INSIST ON AMERICAN FOR QUALITY
Send for FREE Catalog 47



370 South Fair Oaks Ave. • Pasadena, 1, Calif.

NEW PATENTS

the primary, and its impedance, is lowered.

When E_{1n} decreases, E_1 and E_2 reverse polarity. Then only I_2 flows through the secondary. It creates a flux which adds to that in the primary and Z_{1n} increases.

Fig. 2 shows typical waveforms. Z_{1n} varies only while E_{1n} is changing. When the signal is constant, the output is controlled by R and the average value of Z_{1n} .

Charging currents into C_1 and C_2 are in pulse form, so C_3 is added to help the smoothing action across the transformer primary.

FOUR-COLOR KINESCOPE

Patent No. 2,669,671

Lewis B. Headrick, Lancaster, Pa.
(Assigned to Radio Corp. of America)

Most TV technicians know about 3-color kinescopes used for color reception. Here is a new kine that reproduces 4 colors: white in addition to the primary colors, red, green, and blue. The white gun is located at the axis of the tube (Fig. 1). It aims straight toward the screen

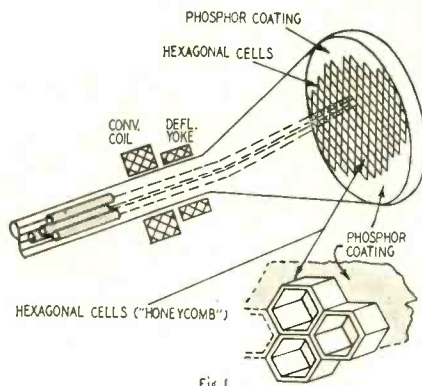

Fig. 1

whose plate is coated with white phosphor. The other guns surround the central one and are spaced by 120° . These aim electrons at a small angle to the axis as in conventional color tubes.

The inner foundation plate of the tube holds banks of hexagonal cells (Fig. 2). Two adjacent sides of each hexagon are coated to glow with one of the primary colors. For example, the blue gun aims electrons so that they hit only the two adjacent sides coated with blue phosphor.

This kinescope must be used with video signals that contain two types of information: detail and color. Detail is contained in the higher frequencies which are delivered to the white gun. The color information is mainly low frequency and it energizes the other guns. For color pictures all four guns are excited.

This tube seems to have advantages where black-and-white pictures are to be received often.

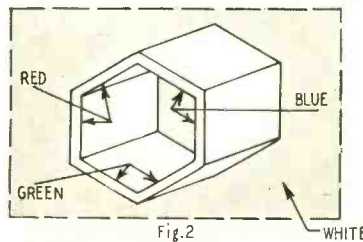
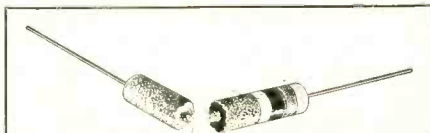

Fig. 2

In these cases only the central gun need be excited and the video signals may be conventional black-and-white information. This is simpler than the present color setup where black-and-white pictures require elaborate color circuits, and white is the result of mixing red, green, and blue in proper proportions. END



Suggested by
Willard I. Nico,
North Hollywood, Calif.
Piece de Resistance

3 NEW RIDER BOOKS RELEASED IN JULY!

1. TV FIELD SERVICE MANUAL VOL. 2

Edited by Harold Alsberg

The finest practical data for in-the-home servicing. Tube layouts; picture tube adjustments; rear and front controls; tube complement; tuner and horizontal oscillator adjustments; key voltages; tuner dial stringing; trouble symptoms; chart with tubes and parts to check; series filament wiring. Book lies flat, spiral binding. Covers 1947 through 1953. Volume 2 covers: Bendix, Capehart, CBS Columbia, Crosley, DuMont. Approx. 160 (5½" x 8½") pages, illus. Soft Cover. **\$2.40**

VOLUME 1. (issued in May) Covers: Admiral, Affiliated Retailers (Artone), Aimcee (AMC), Air King, Air Marshall, Allied Purchasing, Andrea, Arvin and Automatic. 128 (5½" x 8½") pages. Soft cover. **Only \$2.10**

2. HOW TO SERVICE TAPE RECORDERS

Everything you need to know about what is inside a tape recorder—operation of the recording head, types of electronic circuits, kinds of drive mechanisms used, troubleshooting—and how to service the many types of tape recorders, with practical examples. Also discusses requirements for a tape recorder repair shop. Soft cover.

Specialized Auto Radio Manuals

Cover 5 years production (1950 thru 1954) of factory installed car radios. Identical data from other sources is just not available! Contains Parts list, Schematics, Tube layout, Voltages, Trimmer location, Chassis views, Chassis pictures, Dial stringing, and complete installation and removal information. Volumes now available:

VOL. 1-A (released in May) covers Ford . . . Lincoln . . . Mercury. **\$3.00**

VOL. 2-A (released in May) covers Buick . . . Cadillac . . . Oldsmobile. **\$3.00**

VOL. 3-A (released in June) covers Chevrolet, Pontiac, GMC Trucks, Chevrolet Trucks. **\$1.80**

VOL. 4-A (just out) covers Chrysler, DeSoto, Dodge, Dodge Trucks, Plymouth. **\$3.00**

3. INDEPENDENT CAR MANUFACTURERS

VOL. 5-A covers Studebaker, Nash, Hudson, Henry-J, Kaiser-Frazer, Packard, Willys. **\$3.00**

Each volume 8½ x 11". Soft cover.

WRITE FOR COMPLETE 32 PAGE NEW RIDER CATALOG

Buy these books now from your jobber, bookstore,—if not available from these sources, write to:

JOHN F. RIDER		PUBLISHER, INC. 480 Canal Street, New York 13, N. Y.	
In Canada: Mr. Charles W. Panton 1926 Gerrard Street, East Toronto, Ontario	Export Agent: Roburn Associates, Inc. 39 Warren Street New York 7, New York	West Coast Office: 4216-20 W. Jefferson Blvd. Los Angeles, California	Ohio Address: Reburned N. Y.

THE #630 TV RECEIVER remains unmatched for quality and performance • • • RCA designed and developed this set quality-wise *not* price-wise • • • The original 10" set retailed at \$375.00 • • • Subsequent TV sets serve to prove the sacrifice of quality for price • • • what better proof can there be of its superiority than the fact that it is the choice of TV engineers and TV technicians! Herewith we offer you—YOUR BEST BUYS IN TV!—All you pay is the price shown • • • Excise taxes have already been paid by us.

10% Extra Discount

on a Combination purchase of ...

A KIT or any **CHASSIS**
with **CABINET** AND ANY SIZE **PICTURE TUBE**

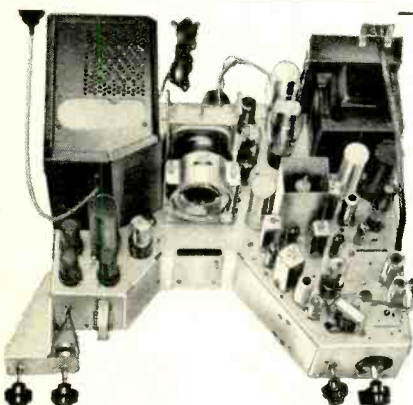

Build your own

#630 Super Deluxe TV CHASSIS

with . . . U. H. F.

With a #630 SUPER DELUXE 31-TUBE TV KIT including your assigned U.H.F. Station • OPERATES 16" TO 24" PICTURE TUBES • Engineered in strict adherence to the genuine RCA #630 plus added features • FULL 4MC BANDWIDTH • CAS-CODE TUNER • COSINE DEFECTION YOKE • LARGER POWER TRANSFORMER • KEYED AGC • 12" SPEAKER • UNIVERSAL MOUNTING BRACKETS • CONDENSERS and RESISTORS at rated capacities and tolerances. You receive a COMPLETE SET OF PARTS and TUBES, everything needed is included (less wire & solder). All I.F. Coils and Transformers are factory pre-aligned and tuned. You will enjoy building it with "LIFE-SIZE easy to follow step-by-step ASSEMBLING INSTRUCTIONS" included with each KIT. NOTHING BETTER AT ANY PRICE!

only . . . **\$119.44** (less CRT)

#630 SUPER DELUXE TV CHASSIS

with **U.H.F.** —Licensed under RCA patents

COMPLETE READY TO PLUG IN AND PLAY—Similar in characteristics and features to the TV KIT at left • Manufactured especially for us by Regal Electronics Corporation • No efforts or expense have been spared in workmanship or materials, to make this #630 SUPER DELUXE TV CHASSIS the Best obtainable for fringe areas, clarity and all-around-performance, regardless of price. Customers report reception better than 200 miles • Each Set is factory aligned and air-tested • All parts carry the RMA three month guarantee • Our mass volume of business on this CHASSIS (numbering thousands of pleased customers) now makes it possible for us to reduce the price to.....

only **\$157.97** (less CRT)

#630 TV SPECIALS ^B _Y TECH-MASTER

27" GOLD MEDAL 2430-9 TV CHASSIS, Complete, ready to plug in and play, including your assigned U.H.F. station. 90° deflection, operates all 24" or 27" rectangular and 30" round picture tubes. The last word in TV achievement • Ideal for wall or custom-cabinet mounting • Detailed technical data mailed on request, however with the knowledge that this CHASSIS is a 30-tube #630 with both TECH-MASTER'S and OUR guarantee, you need not hesitate sending your order in now.

Special at **\$262.50** (less CRT)

COMPLETE LINE OF #630 TECH-MASTERS

VHF entitles you to 1 UHF Station Free. UHF/VHF includes tuner for 82 channels.

	UHF/VHF	VHF
MODEL 2430: For picture tubes up to 24". Audio connection for optional use of external amplifier.	\$249.50	\$189.50
MODEL 2431: Same as 2430, but with True Fidelity Push-Pull audio amplifier.	259.59	199.50
MODEL 2430-9: For new 90° kinescopes. (24" rectangular, 27" and 30").	299.50	262.50
MODEL 1930: Similar to 2430 with slight modifications including area control switch at rear of chassis and cadmium plated finish instead of nickel.	224.95	179.50
MODEL C-30: Designed for the utmost in Quality at an Economical price.	209.95	149.50

(All complete, ready to plug in. Prices NET. CRT not included)

DUMONT or SHELDON FINEST GUARANTEED PICTURE TUBE

MOST desirable 5 sizes—ALL RECTANGULAR • • • BRAND NEW in Factory Sealed Cartons—With a Full Year Guarantee

17" #17BP4A \$29.63 | 20" #20CP4B Aluminized \$39.74 | 21" #21EP4B Aluminized \$44.68 | 24" #24CP4A Aluminized \$66.24 | 27" #27EP4A Aluminized \$82.57

CUSTOM-BUILT CABINETS FOR #630 AND ALL OTHER TV SETS—from FACTORY to YOU

5 LEADING STYLES in genuine mahogany or walnut (blond 10% extra) • Ready drilled for any #630 TV chassis and cutout for any 14", 17", 19", 20" or 27" picture tube at no extras in price • Also supplied with undrilled knob panel for any other TV set • EVERYTHING NECESSARY for an easy perfect assembly is included • Each cabinet is delivered complete as pictured with mask, safety glass, mounting brackets, backboard, backcup, hardware and assembling instructions • Each cabinet is shipped in an air cushioned carton from FACTORY to YOU!

The **VOGUE**
Most Popular
Table Model



H-25", W-20", D-22"

\$39.89

The **MANHATTAN**
Style, Quality, Price

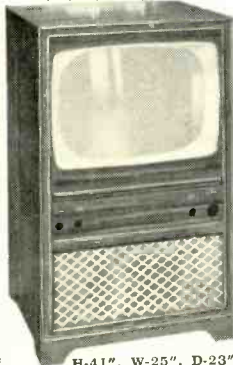

H-41", W-25", D-23"

\$59.37

The **MAYFAIR**

Exquisitely modern, with an elegance of simplicity in styling.



H-40", W-20", D-25"

\$98.56

The **PLYMOUTH**

Choice of interior Decorators, Patterned after the popular credenza, truly superb in every detail. Available for all size picture tubes 14" to 27"

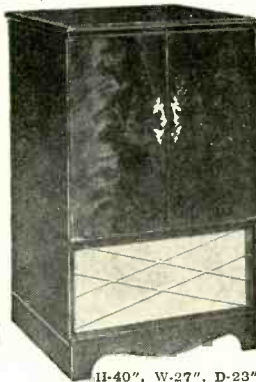

H-40", W-27", D-23"

\$105.48

The **TOWN & COUNTRY**

Patterned after the popular credenza, truly superb in every detail. Available for all size picture tubes 14" to 27"

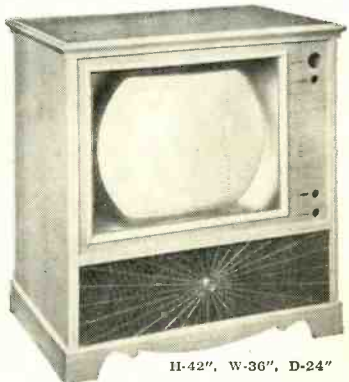

H-42", W-36", D-24"

\$109.62

VOGUE also available for 24" or 27" picture tube
H-31", W-27", D-23"

\$62.54

MANHATTAN for 24" or 27" CRT
H-46 1/2", W-27 3/4", D-24" **\$86.22**

For: 14", 16", 17", 19", 20", 21", 24" or 27" C.R.T.'s

BROOKS RADIO & TV CORP., 84 Vesey St., Dept. A. New York 7, N.Y.

TELEPHONE
Cortland 7-2359

Compare... prove EMC superiority



model 102

(1000 ohms per volt meter) • 3" SQUARE METER • 3 AC CURRENT RANGES (0-30/150/600 ma.) • Same zero adjustment for both resistance ranges 0-1000 ohms, 0-1 megohms) • 5 DC & 5 AC Voltage Ranges to 3,000 volts • Also 4 DC Current Ranges **\$14.90**



model 103

(1000 ohms per volt meter) 4 1/2" SQUARE METER • 3 AC CURRENT RANGES (0-30/150/600 ma.) • Same zero adjustment for both resistance ranges (0-1000 ohms, 0-1 megohms) • Same Ranges as Model 102 • Also 5 DB Ranges **\$18.75**
Model 103-S with plastic carrying strap..... **\$19.25**



model 104

(20,000 ohms per volt meter) 4 1/2" SQUARE METER (50 micro-amperes-Alnico magnet) • Includes carrying strap • 5 DC Voltage Ranges at 20,000 ohms volt to 3,000 V.; 5 AC Voltage Ranges to 3,000 V. • 3 Resistance Ranges to 20 megs • Also 3 AC & DC Current Ranges • 5 DB Ranges **\$26.95**
HYT 30,000 Volt Probe for Model 104 **\$7.95**

EMC

ELECTRONIC MEASUREMENTS CORPORATION
280 LAFAYETTE STREET • NEW YORK 12, N. Y.

EXPORT DEPARTMENT 136 LIBERTY STREET, N. Y. C. N. Y.

Write Dept. RE-8
for Free Complete
Catalogue of these
and other Instru-
ments.

NEW DEVICES

U.H.F. ANTENNA

Channel Master Corporation, Ellenville, N.Y., has announced the development of a new super-fringe u.h.f. antenna, the *Twin Multi-Bow*, model 410-8.

This is an 8-bay bowtie and screen antenna. It has a large screen area, 1,640 square inches, which contributes to the antenna's very high gain, which

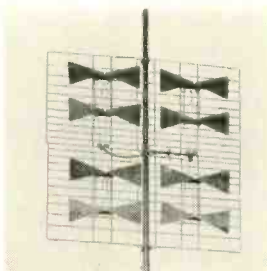

ranges from 12 1/2 to 16 1/2 db. It also gives the antenna a very high front-to-back ratio with a very narrow forward lobe.

Since each dipole is exactly the same distance from the antenna feed points a constant phase connecting harness assures equal current and phase distribution in each dipole over the entire u.h.f. range. This feature—plus 2-stage stacking transformers—results in a flat high-gain level over the entire bandwidth. All harness connections are riveted to the dipoles for positive electrical contact. The dipoles are constructed of aluminum sheet for added strength and improved broad-band characteristics.

TV U.H.F. CONVERTER

General Instrument Corp., 829 Newark Avenue, Elizabeth, N.J., has introduced an all-channel u.h.f. converter called *Tuck-A-Way* which can be installed behind, on either side, on top of and (in the case of certain table models) below the television set. The dial and switch are positioned on top. The switch is of the button type. To in-



stall, one simply plugs the set into the converter, plugs the converter into the wall socket and connects the antenna leads to the converter. It is then ready to tune. Opening and sliding out the heavy chassis is unnecessary.

LINE-LOK STANDOFFS

IE Manufacturing Co., 325 N. Hoyne Ave., Chicago, Ill., has announced a new line of

Line-Lok standoffs. This new design offers many improvements including a cam type separator which keeps the in-



sert firmly against the stem, interlocking side lips to prevent splitting and to maintain a constant locking pressure, and open-end drains that act as an outlet for dust and prevent moisture traps.

The standoff is of the hinge-type design. It clicks open, snaps shut, stays locked in position. It is adaptable for holding most u.h.f. and v.h.f. installations, including the flat line, open line, tubular round and oval line. Pure polyethylene insert isolates the transmission line from the zinc-plated metal stem and produces efficient low-loss performance.

MICA CAPACITORS

Cornell-Dubilier Electric Corp., South Plainfield, N. J., has announced the development of a new style of midget mica capacitor in the form of an encapsulated unit. The capacitor section is separately processed in its entirety and then inserted and sealed with *Permahond* resin fill into a pre-molded case (capsule).

The new *Super Micadon* will house five to six times the capacitance now possible in CM-20 and CM-30 cases. Two sizes are available: type 5A is 51/64 x 15/32 x 7/32 inches; type 1A

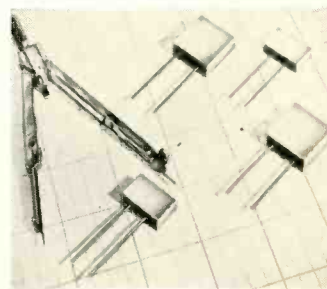

is 53/64 square x 9/32 inches. They occupy only about one-third the space formerly required for the same capacitance, and the life expectancy has also been increased. The capacitors are designed with flat, clinched wire leads, giving improved voltage breakdown safety and enabling over-all inductance to be reduced greatly.

AMPLIFIER KITS

Triad Transformer Corp., 4055 Redwood Ave., Venice, Calif., has introduced four new

NEW DEVICES

amplifier kits. They cover the range from 10 to 40 watts with the HF-12 delivering 10 watts



output. The HF-18, Williamson type, all-triode amplifier delivers 16.5 watts, and the HF-40 auditorium amplifier delivers 40-55 watts. A preamplifier featuring a complete record equalizer and new tone control, designated HF-3, is also provided as a kit. The kits include all necessary transformers, chokes, sectional chassis and complete instructions for assembly—including photographs, drawings, and decals.

CORNER REFLECTOR

Radelco Manufacturing Company, Cleveland, Ohio, is now introducing a new dual-corner reflector, model US-152, with all-metal insulators to free the antenna from variations in received signal strength due to weather conditions. It works equally well in both wet or dry weather and provides positive assurance of high sensitivity

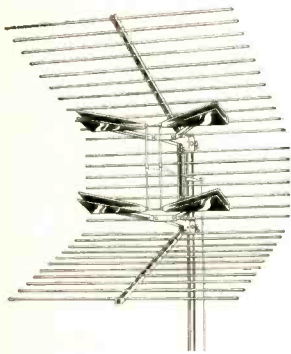

over the entire u.h.f. band. The dipole is supported directly by the mast, and the reflector is constructed entirely of horizontal elements. It discriminates against unwanted vertically polarized signal. The dipole spacing is a full half wave.

NOISE GENERATOR

The Hickok Electrical Instrument Co., 10531 Dupont Ave., Cleveland 8, Ohio, announces the new model 755 universal noise generator for measuring noise factor in radio receivers, tuners, and converters. The unit has a built-in v.t.v.m. with zero-center scales of 0 to 0.1, 0.5, 1.0, and 5.0 volts, and a means of canceling out positive or negative contact potentials up to 1 volt. The output section of the instrument has a decibel meter reading 0 to 19 db with 75- and 300-ohm receiver inputs and 0 to 17 db with 50-ohm inputs. Frequency output is flat from 10 to 250 mc.

The noise diodes are in the probe, thus making it unnecessary to balance out capacitances to the generator. A special u.h.f. head with 50-ohm impedance is available for frequencies between 100 and 1,000 mc. The instrument measures 16½ x 13¼ x 8 inches and weighs

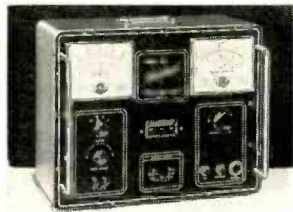

25 pounds. Power consumption is 50 watts from 115-volt, 60-cycle lines.

TV DOT GENERATOR

Sylvania Electric Products, Inc., 1740 Broadway, New York, N.Y., has announced a new color TV dot generator, type 506. It provides a pattern whereby the beams of a color cathode-ray tube of the 3-gun type may be

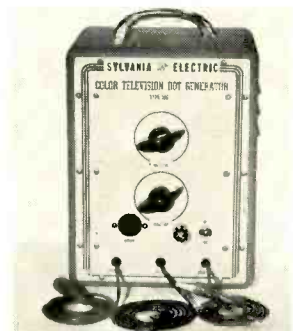

properly converged by the service technician. Sync is coupled directly from the receiver. A wide range of dot spacing is provided for convergence and linearity adjustments. Positive gating and triggered multivibrators assure undistorted output. Test leads permanently fasten to the front panel. It is designed for 105-125-volt, 50-60-cycle operation.

THIRD-DIPOLE KIT

Davis Electronics, P. O. Box 1247, Burbank, Calif., has announced an easy-to-install third dipole which can be used to improve signal reception of a Davis Super-Vision antenna on

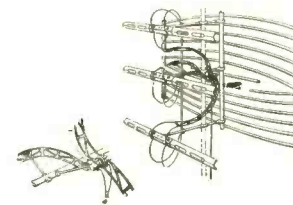

many channels, particularly channels 4, 5, 6, and 7. The kit contains an extra dipole and all necessary accessories as well as installation instructions.

MAIL TODAY

BUILD 15 RADIOS

ONLY

AT HOME \$19.95

With the New Improved 1954

Progressive Radio "EDU-KIT"

NOW INCLUDES
SIGNAL TRACER
and
CODE OSCILLATOR

- ATTRACTIVELY GIFT PACKED
- FREE SOLDERING IRON
- NO ADDITIONAL PARTS NEEDED
- EXCELLENT BACKGROUND FOR TV
- 10 DAY MONEY-BACK GUARANTEE
- SCHOOL INQUIRIES INVITED
- ABSOLUTELY NO KNOWLEDGE OF RADIO NECESSARY

WHAT THE PROGRESSIVE RADIO "EDU-KIT" OFFERS YOU

The Progressive Radio "Edu-Kit" offers you a home study course at a rock bottom price. Our Kit is designed to train Radio Technicians, with the basic facts of Radio Theory and Construction Practice expressed simply and clearly. You will gain a knowledge of basic Radio Principles involved in Radio Reception, Radio Transmission and Audio Amplification.

You will learn how to identify Radio Symbols and Diagrams; how to build radios, using regular radio circuit schematics; how to mount various radio parts; how to wire and solder in a professional manner. You will learn how to operate Receivers, Transmitters, and Audio Amplifiers. You will learn how to service and trouble-shoot radios. You will receive training for F.C.C. license.

In brief, you will receive a practical basic education in Radio, worth many times the small price you pay.

THE KIT FOR EVERYONE

The Progressive Radio "Edu-Kit" was specifically prepared for any person who has a desire to learn Radio. The Kit has been used successfully by young and old in all parts of the world. It is not necessary that you have even the slightest background in science or radio.

The Progressive Radio "Edu-Kit" is used by many Radio Schools and Clubs in this country and abroad. It is used for training and rehabilitation of Armed Forces Personnel and Veterans throughout the world.

All instructions are included. All parts are individually boxed, and identified by name, photograph and diagram. Every step involved in building these sets is carefully explained. You cannot make a mistake.

PROGRESSIVE TEACHING METHOD

The Progressive Radio "Edu-Kit" comes complete with instructions. These instructions are arranged in a clear, simple and progressive manner. The theory of Radio Transmission, Radio Reception, Audio Amplification and servicing by Signal Tracing is clearly explained. Every part is identified by photograph and diagram. You will learn the function and theory of every part used.

The Progressive Radio "Edu-Kit" uses the principle of "Learn by Doing". Therefore you will build radios, perform jobs, and conduct experiments to illustrate the principles which you learn. These radios are designed in a modern manner, according to the best principles of present-day educational practice. You begin by building a simple radio. The next set that you build is slightly more advanced. Gradually, in a progressive manner, you will find yourself constructing still more advanced multi-tube radio sets, and doing work like a professional Radio Technician. Altogether you will build fifteen radios, including Receivers, Transmitters, Amplifiers, Code Oscillator and Signal Tracer. These sets operate on 105-125 V. AC/DC. An Adaptor for 210-250 V. AC/DC operation is available.

THE PROGRESSIVE RADIO "EDU-KIT" IS COMPLETE

You will receive every part necessary to build 15 different radio sets. Our Kits contain tubes, tube sockets, chassis, variable condensers, electrolytic condensers, mica condensers, paper condensers, resistors, line cords, selenium rectifiers, tie strips, coils, hardware, tubing, etc.

Every part that you need is included. These parts are individually packaged, so that you can easily identify every item. A soldering iron is included, as well as an Electrical and Radio Tester. Complete, easy-to-follow instructions are provided.

In addition, the "Edu-Kit" now contains lessons for servicing with the Progressive Signal Tracer, F.C.C. instructions, quizzes. The "Edu-Kit" is a complete radio course, down to the smallest detail.

TROUBLE-SHOOTING LESSONS

Trouble-shooting and servicing are included. You will be taught to recognize and repair troubles. You will build and learn to operate a professional Signal Tracer. You receive an Electrical and Radio Tester, and learn to use it for radio repairs. While you are learning in this practical way, you will be able to do many a repair job for your neighbors and friends, and charge fees which will far exceed the cost of the "Edu-Kit". Here is your opportunity to learn radio quickly and easily, and have others pay for it. Our Consultation Service will help you with any technical problems which you may have.

FREE EXTRAS

- ELECTRICAL & RADIO TESTER
- ELECTRIC SOLDERING IRON
- TV BOOK
- RADIO TROUBLE-SHOOTING GUIDE
- CONSULTATION SERVICE
- QUIZZES
- F.C.C. TRAINING

Progressive "Edu-Kits" Inc., 497 Union Ave., Dept. RE-86, Brooklyn 11, N.Y.

MAIL TODAY—Order shipped same day received.
10-Day Money-Back Guarantee. Include ALL FREE EXTRAS

Send "Edu-Kit" Postpaid. I enclose full payment of \$19.95 (U.S.A. only).

Send "Edu-Kit" Postpaid. I enclose full payment of \$20.95 (Outside U.S.A.).

210-250 V. Adapter for "Edu-Kit"—\$2.50.

Send "Edu-Kit" C.O.D. I will pay \$19.95 plus postage (U.S.A. only).

I wish additional information describing "Edu-Kit". No Obligation.

Send me FREE Radio-TV Servicing Literature. No Obligation.

Name.....
Address.....

PROGRESSIVE "EDU-KITS" INC.

497 UNION AVE., Dept. RE-86, Brooklyn 11, N. Y.

BUILD 15 RADIOS AT HOME WITH THE PROGRESSIVE RADIO "EDU-KIT" MAIL TODAY

high gain

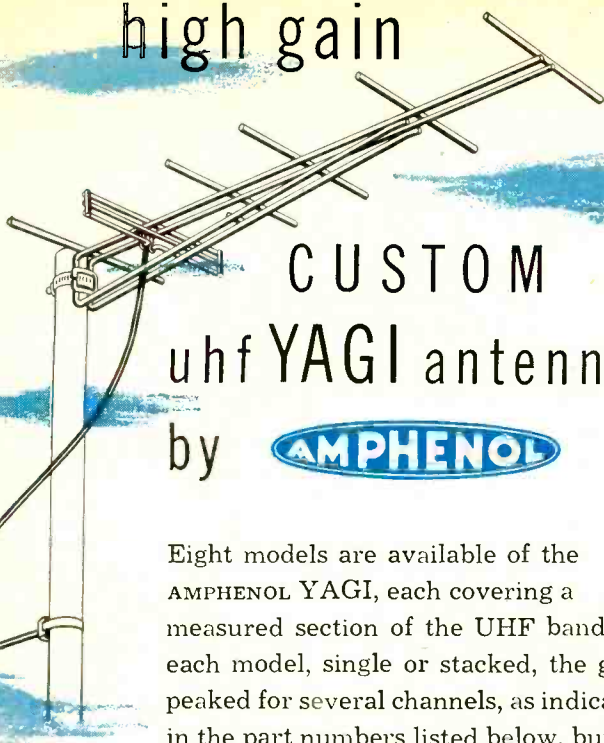

CUSTOM uhf YAGI antennas by AMPHENOL

Eight models are available of the AMPHENOL YAGI, each covering a measured section of the UHF band. On each model, single or stacked, the gain is peaked for several channels, as indicated in the part numbers listed below, but there is more than enough gain on either side of these channel groups to make the YAGI extremely useful in multi-station UHF areas.

Gain of the YAGI is very good. The unique extra-wide spacing of the six elements gives up to 11 db gain on each model. Stacked, this gain reaches as high as 14 db. With its single forward lobe, the YAGI has excellent directional response.

The YAGI is completely pre-assembled and installation is easy and fast. Two YAGIs are easily stacked with the 114-066 YAGI Stacking Harness.

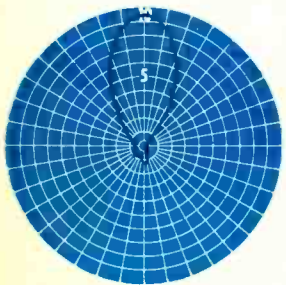

Directivity Pattern
114-054 (24-30)—
Ch. 27

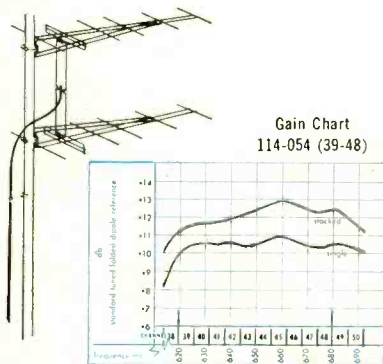

AMPHENOL Part No.	For UHF Channels
114-054(14-17)	14 to 20, single; 14 to 23, stacked
114-054(18-23)	14 to 24, single; 14 to 26, stacked
114-054(24-30)	19 to 33, single and stacked
114-054(31-38)	28 to 41, single and stacked
114-054(39-48)	37 to 51, single and stacked
114-054(49-59)	47 to 60, single and stacked
114-054(60-71)	58 to 73, single and stacked
114-054(72-83)	68 to 83, single and stacked



The Industry's Most Complete Antenna Line

NEW DEVICES

DIALL 51-01

Cannon Electric Co., 3209 Humboldt St., Los Angeles 31, Calif., announces Diall 51-01, a thermosetting-molding compound having diallyl phthalate as its principal resin and asbestos as

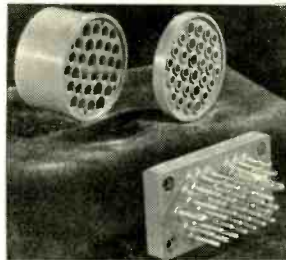

its principal filler. It is currently used for inserts in connectors, solenoid parts, etc. Its main advantage over current materials are its high dimensional stability (.00041-.00101 inch per inch lifetime shrinkage), higher heat resistance (400° to 450° F. continuous exposure), better resistance against cracking during soldering operations, and higher impact strength.

ALL-CHANNEL TV TUNER

Sarkes Tarzian, Inc., Tuner Division, Bloomington, Ind., announces the new UV-13 all-channel v.h.f.-u.h.f. TV tuner. The unit consists of the V-13 v.h.f. tuner and the U-13 u.h.f. tuner plugged together with con-

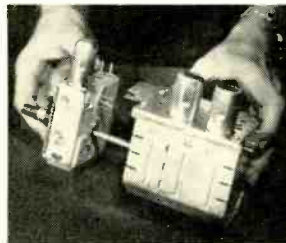

centric control shafts to make an all-channel tuner 4 3/4 inches deep, 3 17/64 inches high, and 3 5/16 inches wide. The V-13 is a turret-type cascade tuner with a 6BZ7 r.f. amplifier and 6U8 mixer-oscillator. Its output is link-coupled for a 41-mc i.f. system. Power and antenna connections are made to pin-type terminals. Soldered connections are not used for installation.

The U-13 is a capacitance-tuned u.h.f. tuner using a resonant coaxial cavity. It may be installed at the factory or in the field. The U-13 slips over the shaft of the V-13 and plugs into the front of it. Two screws hold the assembly together. When a u.h.f. channel is tuned in the V-13 becomes a 2-stage i.f. amplifier.

Three concentric tuning knobs are used for coarse and fine tuning of v.h.f. and u.h.f. channels.

40-MC I.F. STRIP

Allen D. Cardwell Electronics Productions Corp., (Subsidiary of Chesapeake Industries, Inc.), Plainville, Conn., announced the

development of a 40-mc printed circuit i.f. amplifier for monochrome TV receivers using inter-carrier systems.



This unit includes a new laminate, used on both the base and transformers to improve electrical characteristics and mechanical rigidity and reduce the usual brittleness. The transformer windings are etched on both sides of the laminate. Aluminum discs are threaded into center-tipped nylon inserts. The insert prevents any possibility of the formerly bothersome shorting of turns.

AM-FM TUNER

Freed Electronics & Controls Corp., 200 Hudson Street, New York 13, N. Y., has announced its new Freed-Eisemann AM-FM superheterodyne radio tuner, model 750, which incorporates high-fidelity performance with sufficient sensitivity to provide optimum reception even in fringe areas. The AM and FM circuits are designed for maximum gain at minimum noise. The unit contains a whistle filter which eliminates interstation whistles.

NEW SUPER METER

Superior Instruments Co., 2435 White Plains Rd., New York 67, N.Y., has announced a new Super Meter, model 670-A. It includes a built-in isolation transformer which reduces the possibility of meter damage by 50%. It will measure capacitance, reactance, inductance, and decibels. It also includes a Good-Bad scale for checking the quality of electrolytic capacitors at 150 volts.

The d.c. volt range is 7.5, 15, 75, 150, 750, 1,500, and 7,500. The a.c. ranges are 15, 30, 150,



300, 1,500, and 3,000. Output volts: 15, 30, 150, 300, 1,500, and 3,000. There are five current ranges: 1.5, 15, and 150 ma, and 1.5 and 15 amperes. Resistance ranges are 1,000 and 100,000 ohms and 10 megohms. Capacitance can be measured from .001 to 1 µf and from 1 to 50 µf; reactance from 50 to 2,500 ohms and from 2,500 ohms to 2.5 megohms; inductance from 0.15 to 7, and from 7 to 7,000 henries. Decibel ranges of -6 to +18, +14 to +38, and +34 to +58 are included.

HI-FI CARTRIDGES

Astatic Corp., Conneaut, Ohio, has announced a new high-fidelity cartridge, model 51-1-J, called the *Con-Am*. Since this cartridge has no magnets, it can be used

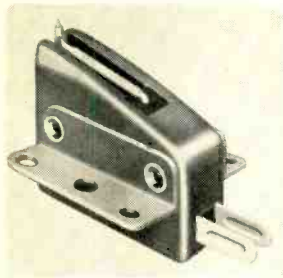

over a steel turntable without affecting needle pressure. Hum pickup is also reduced. The response is 30 to 15,000 cycles per second on the RCA 12-5-51V test record. Output is 0.70 volts, nominal, on RCA 12-5-31V at 1,000 cycles per second. Compliance is 10-6 cm/dyne. One replaceable stylus is furnished, with diamond or sapphire tip, and with one-mil tip radius for slow speed recordings or three-mil tip for 78 r.p.m.

3-WAY LOUD-SPEAKER

University Loudspeakers, Inc., 80 Kensico Ave., White Plains, N. Y., has announced a new 3-way high-fidelity loudspeaker system called the *Companion*. It

employs a combination of woofer, mid-range and tweeter reproducers together with a full-fledged inductance-capacitance type dividing network; and is housed within a balanced double-port bass chamber. The system itself consists of a *Diffusicone-8* and a University model 4401 tweeter system.

An electrical crossover network separates the low and middle from the high frequencies. The woofer section of the *Diffusicone-8* has a heavy-duty diaphragm capable of large low-frequency excursion without acoustic breakup; and the mid-range *Diffuser* section provides two separate and concentric horn radiators which achieve wide angle radiation through the diffraction ring terminating the mouth area of the diffusion system. The tweeter is a driver unit with a light-weight phenolic diaphragm, an Alnico V magnet, and a wide-angle horn. A balance control is provided in

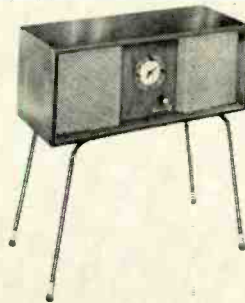

the network to adjust the tone quality of the system to fit the program material being played.

The *Companion* is equipped with a Sessions electrical preset clock which tells time and permits the speaker to be used to automatically turn on and off the radio, phonograph, or tape recorder, or any other appliance.

U.H.F. CONVERTER

Blonder-Tongue Laboratories, Inc., 526 North Avenue, Westfield, N. J., has put on the market their new model 99 low-noise all-channel u.h.f. converter for class A signal areas.

The 300-ohm impedance match throughout provides maximum signal power and clarity. The tuned input tracks with the oscillator and eliminates spurious



responses and suppressing radiation. There is one-knob tuning over the entire u.h.f. band, with output to the TV set on channels 4, 5, and 6. A selector knob switches reception from u.h.f. to v.h.f.

The oscillator circuit is thermally compensated for drift-

free operation. The converter has a built-in power supply and employs an Ultratuner. It uses a 6T4 tube, crystal diode mixer, and selenium rectifier, and operates on 117 volt, 60-cycle a.c.

LIGHTNING ARRESTOR

Radion Corp., 1130 West Wisconsin Ave., Chicago 14, Ill., has introduced its new LA-75 lightning arrestor which handles all types of conventional lead-in: open, flat, jumbo, oval, and perforated.

The mounting strap is an integral part of the arrestor. No separate strap or bracket is required. The arrestor can be mounted on a wall, or any pipe up to 1½ inches. One end of the mounting strap is designed to grip the No. 8 ground wire generally used by service technicians to ground an arrestor. The grip is operated by the mounting screw.

TV REPLACEMENTS

Chicago Standard Transformer Corp., Addison & Elston, Chicago 18, Ill., has announced the addition of 38 new television transformer replacements. These replacements include 23 power transformers, 8 vertical output transformers, 5 width and linearity controls, 1 deflection yoke, and 1 filter choke. The power transformers are exact replacements for Motorola, Philco, RCA, Zenith, Silvertone, and many other types. **END**

All specifications given on these pages are from manufacturers' data.

Get This Valuable Book

Just for Examining COYNE'S New 6-Volume Set

FREE

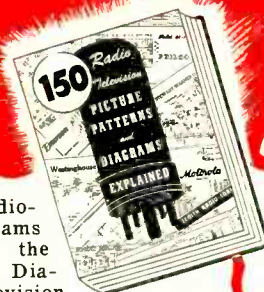

"Applied Practical Radio-Television"

ON 7 DAY FREE TRIAL!



Yes, you get this big, new 1954 book, "150 Radio-Television Picture Patterns and Diagrams Explained", absolutely FREE! Just off the press! Gives complete 11x22" Schematic Diagrams on leading models Radio and Television Sets. Easy-to-read, large 8½x11" pages, with full instructions on how to read and use the diagrams. A "must" in every Radio and Television service-man's repair kit. You get this valuable book as a FREE Gift for asking to see Coyne's great new 6-book set, "Applied Practical Radio-Television"!

At Last! Money-Making "Know-How" on Transistors, Color TV and Servicing

Coyne's great new 6-volume set gives you all the answers to servicing problems—quickly! For basic "know-how" that is easy to understand, you'll find everything you want in volumes 1 to 5 which contain over 5000 practical facts and data. They cover every step from principles to installing, servicing, trouble-shooting and aligning all types of radio and TV sets. So up-to-date it includes COLOR TV and UHF, adapters, converters. Also covers latest data on TRANSISTORS.

Extra! 802-Page Television Cyclopedic Included

And then, for speedy on-the-job use, you get volume 6—the famous Coyne TELEVISION CYCLOPEDIA. It answers today's television problems on servicing, alignment, installation and others. In easy-to-find ABC order, cross indexed. Use this 6 volume TV-RADIO LIBRARY free for 7 days; get the valuable Servicing Book ABSOLUTELY FREE!

SEND NO MONEY! Just mail coupon for 6-volume set on 7 days free trial. We'll include book of 150 TV-Radio Patterns & Diagrams. If you keep the set, pay \$2 in 7 days and \$2 per month until \$22.50 plus postage is paid. (Cash price \$20.95). Or you can return the library at our expense in 7 days and owe nothing. **YOU BE THE JUDGE.** Either way, the book of TV-Radio Patterns is yours FREE to keep! Offer is limited. Act NOW!

FREE BOOK—FREE TRIAL COUPON!

COYNE ELECTRICAL & TELEVISION-RADIO SCHOOL, Dept. 84-T1
500 S. Paulina St., Chicago 12, Ill.

YES! Send 6-volume "Applied Practical Radio-Television" for 7 days FREE TRIAL per your offer. Include TV-Radio Patterns & Diagram Book FREE.

Name _____ Age _____

Address _____

City _____ Zone _____ State _____

Where Employed _____

() Check here if you want library sent COD. You pay postman \$20.95 plus COD postage on delivery. 7-day money-back guarantee.

COYNE ELECTRICAL & TELEVISION-RADIO SCHOOL
500 S. Paulina St., Dept. 84-T1 Chicago 12, Ill.

Trav-Electric

DC to AC

CURRENT CONVERTERS for Land... Sea... Air

JUST PLUG INTO CIGAR LIGHTER ON DASH
Change 6 or 12 Volt D. C.
to 110 Volt A. C. - 60 cycle



Operates Test Equipment,
All Electric Shavers

SIZE: 2" x 2" x 3 1/2"

Trav-Electric MIDGET

List \$11.95

Model 6-11160, 60 Cycle, 10-15 Watts



- OPERATES
- Test Equipment
 - Turntables
 - Lights
 - Short, Long Wave Radios
 - Portable Phonographs
 - Electric Shavers, etc.

SIZE: 2 1/2" x 2 1/2" x 4 1/2"

Trav-Electric SENIOR

List \$15.95

Model 6-1160, 60 Cycle, 35-40 Watts



- OPERATES
- Curling Irons
 - Radios
 - Turntables
 - Small Dictating Machines
 - Test Equipment
 - Electric Shaver
 - Portable Phonographs

SIZE: 4" x 5" x 6"

Trav-Electric MASTER

List \$24.95

Model 6-51160, 60 Cycle, 40-50 Watts



- OPERATES
- Wire Recorders
 - Amplifiers
 - Soldering Iron
 - Radios
 - Dictating Machines
 - Turntables
 - Small Electric Drill
 - Electric Shaver

SIZE: 4" x 5" x 6"

Trav-Electric SUPER

List \$37.95

Model 6-71160, 60 Cycle, 60-75 Watts

FULLY GUARANTEED
See your Jobber or Dealer
Terado COMPANY
1057 Raymond Ave.
ST. PAUL 14, MINNESOTA

In Canada Write: Atlas Radio Corp., Ltd.
560 King St. West, Toronto 28, Ont.
Export Sales Division: Scheel International, Inc.
4237 N. Lincoln Ave., Chicago 18, Ill. U.S.A.
Cable Address—Harsheel

QUESTION BOX

6AL7-GT IN FM TUNER

I would like to add a 6AL7-GT tuning indicator to a Heathkit FM-2 FM tuner. Please show the necessary connections.—S. K., Mount Vernon, N. Y.

A. The dashed line shows the connection between the 6AL7-GT and the discriminator circuit in the tuner.

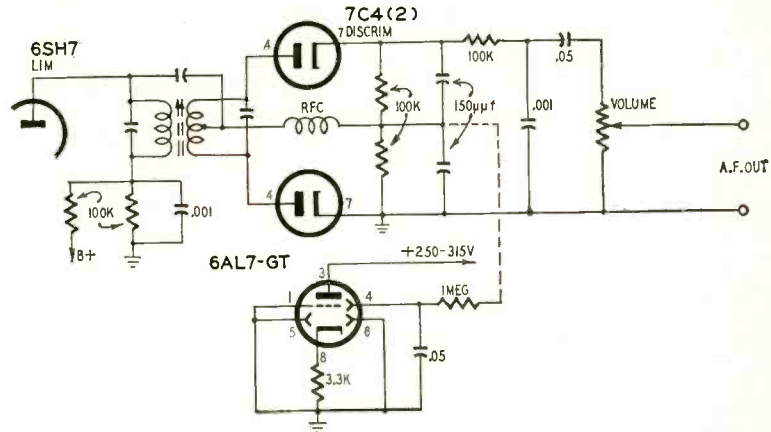

IMPROVING ALL-WAVE SETS

I have two all-wave radios that I want to convert into amateur communications receivers for use by the high-school science club. One set is an RCA 3BX-671 and the other is an a.c. type of unknown make using a 5Z3, 42, 75, 6D6, and 6A7. Please show how I can add electrical bandspread tuning and beat-frequency oscillators to these sets.—E. O. C., Mamaroneck, N. Y.

Connect a small ganged air trimmer capacitor across the sections of the main tuning capacitor for bandspread tuning. The trimmer or bandspread capacitor should have the same number of sections as the main tuning capacitor. A maximum capacitance of about 25 µf per section will be about right. A small FM tuning capacitor should work nicely. The amount of bandspread increases as the maximum capacitance of the bandspread capacitor is decreased. A good vernier or slow-motion dial drive on the bandspread capacitor makes tuning easier.

The diagram at a in Fig. 1 shows a b.f.o. circuit for use in battery and 3-way receivers. The b.f.o. coil may be a J. W. Miller type in the 012, 112, 512, 612, or 912 series. Select one that tunes

through the i.f. of the receiver.

Modifying the filament circuit of a 3-way portable to include the b.f.o. tube necessitates major changes in the receiver. The simplest solution is to use a separate battery—a standard size D flashlight cell will do for the b.f.o.

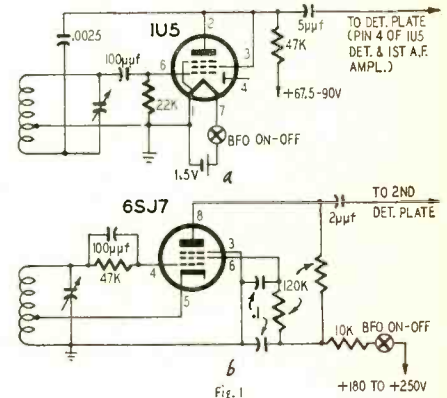

tube as shown in the diagram at a.

Fig. 1-b is the circuit of a b.f.o. suitable for use in an a.c. receiver. The coil specifications are as in Fig. 1-a.

BATTERY ELIMINATOR

Please print a circuit of a battery eliminator for a portable battery radio using a 90-volt B battery and a 4.5-volt A battery.—E. W., Brooklyn, N.Y.

The eliminator in the diagram operates from a.c. or d.c. lines and delivers up to about 9 volts at 50 ma for series-connected filaments and up to 90 volts or so at 15 ma for plates and screens.

Most battery sets use the chassis as the common negative return. Therefore, it is important that the chassis of the set should be fully enclosed in a non-conductive cabinet with no exposed screws or other metal connecting the chassis to the outside. If the set has exposed hot points that cannot readily be insulated, insert a 115-volt, 75-ma half-wave type transformer between

the line and rectifier input. If you can't find a suitable transformer, use two 6.3-volt, 3-amp transformers back-to-back.

Before connecting the eliminator to the set, adjust the 1,000- and 10,000-ohm output controls to deliver correct voltages to dummy loads equal to the loads imposed by the A and B circuits in the set. In a 4-tuber, connect a 90-

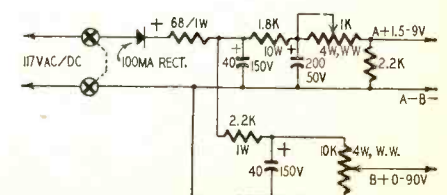

QUESTION BOX

ohm, 1-watt resistor across the A terminals and an 8,200-ohm, 2-watt resistor across the B terminals, and then adjust the controls for correct voltages.

Turn off the eliminator, remove the two dummy loads, and then connect the eliminator to the receiver. Turn on the set and eliminator and touch up the settings of the voltage controls.

To adjust the eliminator for sets with higher filament voltages and different B voltages, calculate the values of the dummy load resistors by dividing the voltage by load current. The B supply drain is about 11 ma for 4-tube sets and 15-16 ma for 5-tube models.

TV INTERCARRIER CONVERSION

I installed a cascode tuner in an RCA TA-128 TV receiver. It works nicely on v.h.f. channels but I cannot eliminate separation of picture and sound on channel 16. I'd like to convert this set to an intercarrier type but I can't find a suitable point for the sound take-off and input to the first 4.5 mc sound i.f. amplifier.—D. R., Mount Morris, Michigan.

First, we recommend that you try touching-up the i.f. alignment and substitute different 6J6's in the tuner and see if you can't find one that minimizes drift. If these steps do not help, conversion to intercarrier sound may be the solution to the problem.

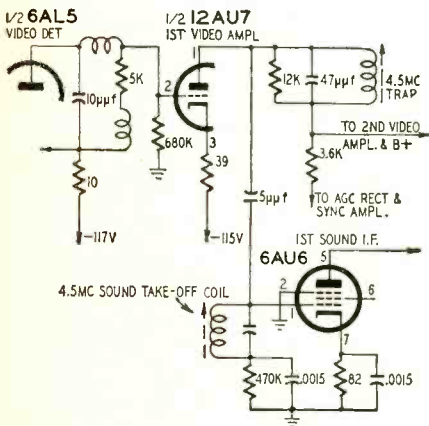

Replace the 21-mc sound i.f. interstage and discriminator transformers with 4.5-mc equivalents. Disconnect the grid of the 6AU6 first sound i.f. amplifier from the tap on the 21-mc sound take-off and remove the 470,000-ohm resistor and .0015-µf capacitor from the bottom of this coil. Connect this R-C network and a 4.5-mc sound take-off coil in the grid circuit of the first sound i.f. amplifier as shown in the diagram.

Connect the plate of the first video amplifier to the grid of the first sound i.f. amplifier through a 5-µf ceramic capacitor. Keep the sound take-off lead short. If you have sound bars in the picture with the 4.5-mc trap peaked, try using low-capacitance coaxial cable for the sound take-off lead.

Realign the i.f. circuits to give optimum intercarrier performance. END

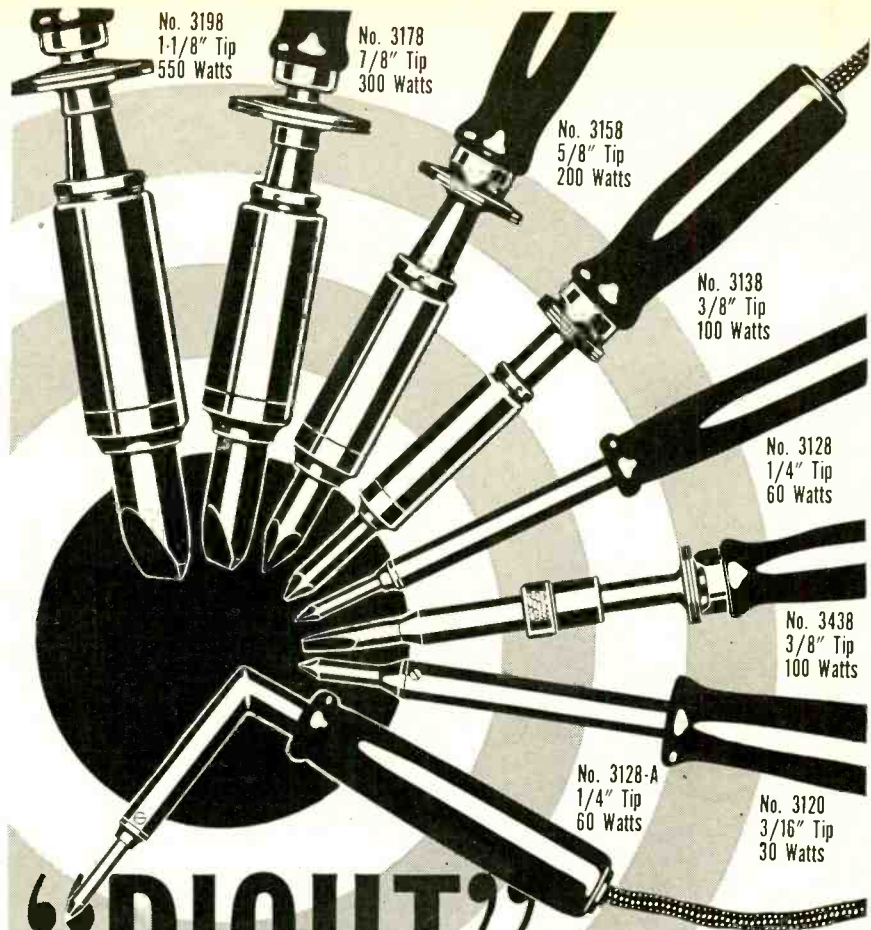

“RIGHT” AT THE TIP!

THAT'S WHERE THE HEAT IS CONCENTRATED IN ALL

American Beauty

ELECTRIC SOLDERING IRONS

. . . and that's why ANY model of American Beauty Electric Soldering Iron can be chosen with the assurance that it is absolutely **DEPENDABLE—DURABLE—EFFICIENT** . . . from tip to attachment-plug cap.



Four new models have recently been added to our line. They are No. 3120, 3/16" tip, and its companion iron (No. 3118, 1/8" tip) and No. 3438, 3/8" tip, and its companion iron (No. 3438-EP, 3/8" Eternalloy-Plated tip).

The first two are "Bantam" irons—extremely light but ruggedly-built, small-diameter tip irons designed especially for television, radio, radar and similar precision instrument soldering.

The last two are production-line irons embodying a new type of heat application with the element permanently embedded in the tip for maximum heat-conductivity from tip to the work.

Write for descriptive literature.

AMERICAN ELECTRICAL HEATER COMPANY

DETROIT 2, MICHIGAN

No. H-142



RADIO-ELECTRONIC CIRCUITS

AUTOMATIC BAND SCANNING

When an r.f. carrier is tuned in on a superregenerative receiver, the hiss level drops. The stronger the signal, the weaker the hiss. A New Zealander uses this hiss to control the motor of an automatic tuning circuit on a 2-meter receiver. This relieves the operator of the tiring task of tuning endlessly from one end of the band to the other while waiting for the band to open and let dx through.

The diagram shows the control circuits of a 2-meter receiver described in *Radio and Electronics*. The motor connects to the tuning capacitor through

fier develops a negative voltage used to bias the 6V6 to cutoff.

The motor control relay is in the plate circuit of the 6V6 audio output stage. In the absence of a superregenerative hiss audio signal, the 6V6 is cut off and the motor circuit is completed through the back contacts on the relay. The motor drives the tuning capacitor through a speed-reducing pulley system. When the set tunes across an unmodulated carrier the hiss level drops and decreases the output of the bias rectifier. The 6V6 conducts and energizes the relay coil. The motor circuit then



"Since I got this Hi-Fi rig with a JENSEN NEEDLE, business is jumping."

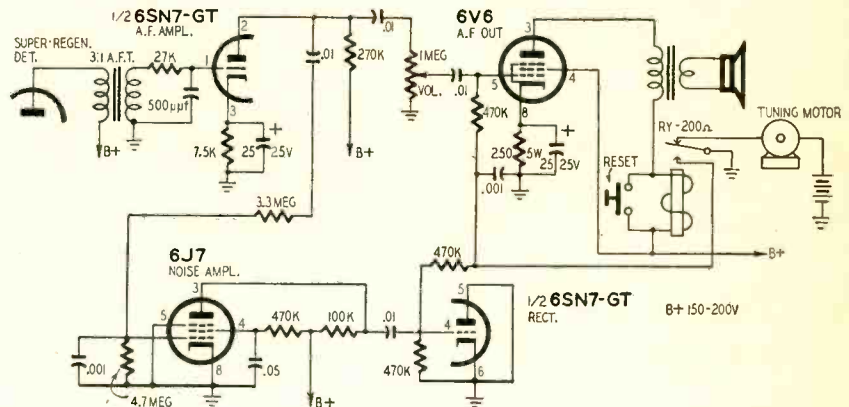

a dial-drive system which permits the band to be scanned at a reasonably slow rate.

The output of the detector is transformer coupled to one-half of a 6SN7-GT used as an audio amplifier. The output of this stage is R-C coupled to the control grids of the 6V6 a.f. output stage and the 6J7 noise amplifier. The coupling network in the grid circuit of the 6J7 is designed to favor the hiss frequency range. The noise amplifier feeds a half-wave rectifier using the remaining half of the 6SN7. The recti-

fers opens and the control line shorts to ground at the bottom end of the 470,000-ohm resistor in the 6V6 grid circuit. The relay remains energized.

To start the motor scanning again, the operator closes the momentary switch to short-circuit the relay coil and complete the circuit to the motor.

If the set tunes across a modulated signal, the audio has the same effect as hiss on the control circuit, so the motor continues to scan until the set tunes across the carrier during a break or pause in modulation.

NOVEL A.V.C. CIRCUIT

An infinite impedance detector is often used in high-fidelity AM tuners because its high input impedance does not load the tuned circuit feeding it. One disadvantage of this circuit is that a.v.c. voltage cannot be readily supplied by it. When a.v.c. is required, the usual expedient is to capacitance-couple a diode rectifier to a winding on the last i.f. or r.f. transformer. In either case, the a.v.c. diode loads the tuned circuit and nullifies the advantage of high input impedance provided by the infinite-impedance detector.

In *Radio Constructor*, London, Eng-

land, G. A. French shows an interesting solution to the problem of obtaining a.v.c. voltage from an infinite-impedance detector without loading the input circuit. He uses an additional i.f. transformer (T1) in the cathode circuit of the detector between load resistor R1 and r.f. filter capacitor C1. (See diagram.) In this arrangement, the detector input circuit is not affected. The secondary of T1 feeds a conventional half-wave rectifier that develops the a.v.c. voltage.

The shape of the r.f. pulses flowing through the primary of T1 may produce

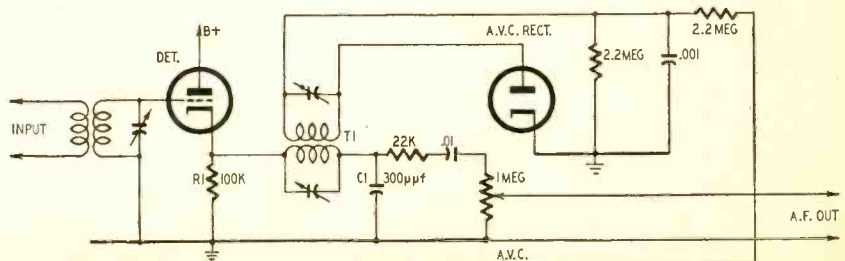

precise TRANSISTOR KIT

Here is the unique **PRECISE TRANSISTOR KIT** that supplies you with all the components necessary to perform innumerable experiments . . . along with many prepared experiments including audio one stage amplifiers through transformer-coupled amplifiers . . . and into special circuits. Instruction book teaches you the theory of transistors in simple non-mathematical terms.

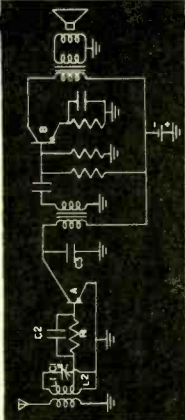

- ★ Audio oscillator
- ★ RF oscillator
- ★ Signal tracer
- ★ Tuned signal tracer (TRF type receiver), etc.

T1 . . . Kit \$17.95

WRITE FOR 1954 CATALOG INCLUDING NEW HIGH FIDELITY INSTRUMENTS IN KIT & WIRED FORM

PRECISE DEVELOPMENT CORP.
Oceanside, New York

RADIO-ELECTRONIC CIRCUITS

a higher a.v.c. voltage when the secondary is connected in a certain way. Try reversing the leads to the secondary winding for a higher a.v.c. voltage.

AUDIO MICROVOLTER

When checking distortion or making frequency runs on audio equipment, the technician may find that the generator's output attenuator is not sufficiently accurate to drop the signal to the level normally found at the input of preamplifiers and high-gain a.f. amplifiers. This difficulty can be eliminated by using an accurate external attenuator consisting of step and continuously variable elements and a meter for setting the input to a predetermined level. Such a device is called a *microvolter*. The simple one described here, through the courtesy of Cornell-Dubilier Electric Corp., is sufficiently accurate for most servicing and experimental uses.

The unit can be constructed in a metal utility box. The smallest dimensions depend on the diameter of the meter. With a 1-inch meter, the unit

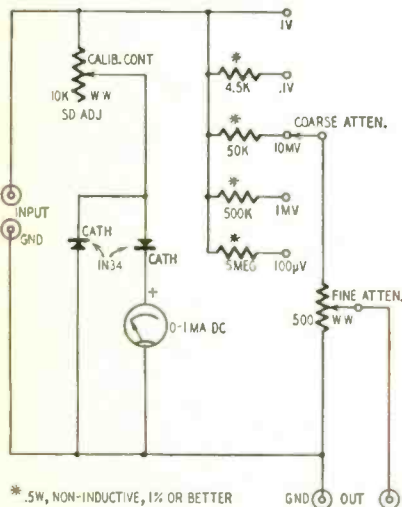

*.5W, NON-INDUCTIVE, 1% OR BETTER

can be constructed in a 7 x 5 x 3-inch box without cramping.

The microvolter is calibrated by applying a 1-volt r.m.s. signal to the input terminals and adjusting the 10,000-ohm calibration control so the meter reads exactly half-scale. This control should be fitted with a slotted shaft and lock nut which prevent the setting from being changed accidentally.

The coarse attenuator provides outputs from 100 μ V to 1 volt in six steps when the fine control is set to maximum resistance. The fine attenuator is a 500-ohm linear wirewound potentiometer. Use an accurate ohmmeter or bridge to set the control so there is exactly 500 ohms between the arm and the lower terminal. Mark this point 10 on a dial scale. Decrease the resistance in 25-ohm steps and calibrate the remainder of the scale in one-half points. For example: 475 ohms is 9.5, 450 ohms is 9.0, 425 ohms is 8.5, 400 ohms is 8 and so on.

END

In HI-FI ENCLOSURE KITS

ONE
NAME
STANDS
OUT

KARLSON

ULTRA-FIDELITY ENCLOSURES

Karlson Ultra-Fidelity Enclosures feature the entirely new acoustics principle — the Exponential Coupler . . . which creates a profound sound improvement over all other makes, regardless of price or size.

Best in Bass: 16 cycle bass response with a good speaker

Best in Looks: Beautiful design matches any decor

Best in Price: 16 models from \$45 to \$117.60

Best in Every Way: Dispersion of the highs
Phasing
Transient Response
Definition of tone
Efficiency
Small 34" x 22" x 18"
Sturdy Construction



DON'T THROW OLD RADIOS AWAY

Here's the data you need
to fix them FAST and r-i-g-h-t

There's a "secret" to repairing old radios fast and profitably and this big RADIO TROUBLE-SHOOTER'S HANDBOOK is it! Just look up the old make and model you want to fix. This manual-size, 3 1/2 pound, 744-page Ghirardi handbook tells what the trouble is likely to be . . . and shows you exactly how to fix it. No useless testing! No wasted time! Even beginners can handle jobs "sleek as a whistle."

THE ONLY GUIDE OF ITS KIND

Cuts service time in half!

Included are common trouble symptoms and their remedies for over 4,800 models of old home and auto radios and record changers. Actual case histories cover practically every model made by 202 manufacturers between 1925 and 1942—Arline, Apex, Arvin, Atwater Kent, Belmont, Bosch, Brunswick, Clarion, Crosley, Emerson, Fada, G-E, Kolster, Majestic, Motorola, Philco, Pilot, RCA, Silverstone, Sparton, Stromberg, and dozens more. Gives how-to-in-it data on SPECIAL jobs—NOT general theory. Includes hundreds of pages of invaluable tube and component data, wiring short cuts, etc.

. . . TRY IT 10 DAYS . . . at our risk! . . .

Dept. RE-84, RINEHART & CO., Inc.
232 Madison Ave., New York 16, N. Y.

Send Ghirardi's RADIO TROUBLESHOOTER'S HANDBOOK for 10-day free examination. If I decide to keep book, I will then remit the full price of only \$6.50 plus a few cents postage. Otherwise, I will return book postpaid and owe you nothing.

NAME.....

ADDRESS.....

CITY, ZONE, STATE.....

IN KIT FORM

SELF- ASSEMBLING \$45 KIT

- 51 intricately cut pieces
- All 3/4" Fir plywood for best acoustic results
- Complete finishing instructions

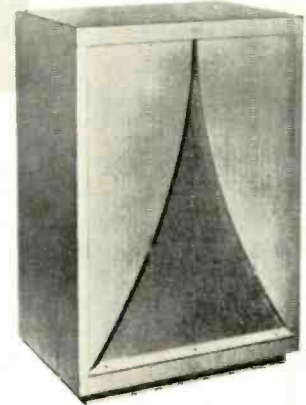

If not yet available from your Hi-Fi dealer, order direct

Send for Complete Literature

KARLSON

ASSOCIATES, INC.

DEPT. K

1379 E. 15th St., Brooklyn 30, N.Y.

precise TEST INSTRUMENTS

(in KIT and WIRED FORM)

#111

#700

#308

#971

With professional and amateur alike, PRECISE is the foremost choice. PRECISE insures the use of the finest components in the finest precision-engineered equipment. Fully guaranteed, PRECISE instruments and kits use NO SURPLUS, what's more, kits contain easy-to-follow 3-color step-by-step instruction books.

Send for complete PRECISE 1954 Catalog JM which includes the amazing #111 Emiss on and Mutual Conductance TUBE TESTER.

PRECISE DEVELOPMENT CORP.
Oceanside, New York

CANNON Sub-Miniature PLUGS

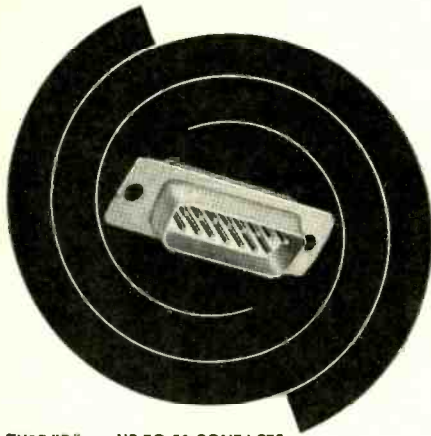

TYPE "D" . . . UP TO 50 CONTACTS

For Your Miniaturization Program!

Save space . . . save weight . . . rugged. 1000's of uses! Pressed steel shells. Heavily gold-plated copper-alloy 5-amp. contacts give untarnishing high surface conductivity and corrosion resistance. Take #20 solder-tipped wires. Polarization means. Salt-spray resistant shells. Flashover 1700v dc.

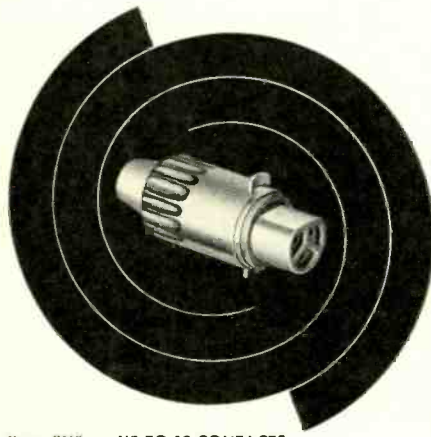

TYPE "U" . . . UP TO 12 CONTACTS

Receptacles Hermetically-sealed

Round steel shells. Pin receptacles have fused vitreous insulators to give true hermetic seal. Adaptable to box-or panel-mounting. Pin or socket plugs have resilient moisture-sealing insulators, gold-plated contacts. Bayonet latch. Cord connectors have resilient sleeves. Contacts 5-amp. Flashover 1700v dc.

Write for Cannon Sub-Miniature Bulletins . . . TODAY! Refer to Dept. 144.

CANNON ELECTRIC COMPANY, 3209 Humboldt St., Los Angeles 31, Calif. Representatives and Cannon distributors in all principal cities.



Since 1915

CANNON ELECTRIC

TRY THIS ONE

SOLDERING IRON CONTROL

I use this control unit to regulate the heat of my bench soldering iron so it is always ready for instant use but not hot enough to burn the tip. The control is made from an old power transformer and a heavy-duty double-pole 3-position switch. The 6-volt winding is polarized so it is in series-aiding

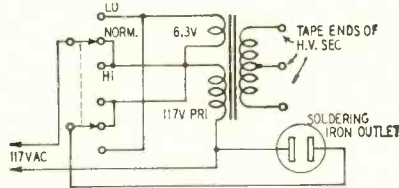

with the primary.

The LOW position keeps the iron hot without burning when it is not being used and the HIGH position is for extra heat when needed.—Leonard Pfeiffer

SUBSTITUTE PHONE JACK

A surplus J-26 extension phone jack is an acceptable substitute when a panel type is not available. Remove the shell and run a nut upon the threaded shank. Push the shank through the hole in the panel or chassis and anchor it in place with another nut. These jacks have been available on the surplus market for considerably less than panel types, so I recommend them whenever cost is a factor and space permits their use.—Harold J. Weber

HOLDER FOR TEST LEADS

Test leads are troublesome to carry whether they are wound around the meter or just tossed in the tool box. Here is a way to keep them from snarling. A neat little carrying case for leads can be made from an empty plastic bottle of the type used for spray cosmetics. Cut out the bottom, then wind the leads about the fingers into a small roll, and push the roll into the plastic case.

Enough of the wire will be contained to make a neat package and keep it from unrolling.—Hugh Lineback

TAILOR-MADE BANDSPREAD

Most commercial communications receivers do not have bandsread that is satisfactory for all kinds of reception. If it is good for single sideband, or for c.w. with a sharp i.f. amplifier and peaked audio system following it, it takes forever to tune through an AM phone signal. Conversely, if it permits quick and easy scanning of the phone bands, it is far too critical and fatiguing for really sharp c.w. or single sideband. What is obviously called for is various degrees of bandsread, each suited to particular operating conditions.

The answer is extremely simple with a home-grown receiver. The easiest way to build a front end for a ham-band receiver is to use plug-in coils, broadband the r.f. and mixer stages, and

NOW- STEP AHEAD FASTER! AS AN INDUSTRIAL ELECTRONICS TECHNICIAN

Turn your experience into a big, new, better-paying career!

Day by day industrial plants are adding more electronic devices—for sorting, counting, checking, almost any control job you can name. Cash in on industry's great need for men who can keep these devices in top working order. Make more money, feel more secure, doing work that is second nature to you. With what you already know about electronics you have a long head start in a field just beginning to boom. GET INTO IT RIGHT NOW with the help of

PRACTICAL INDUSTRIAL ELECTRONICS LIBRARY

4 Volumes
1390 pages
1050 illus.

\$22.50
EASY
TERMS

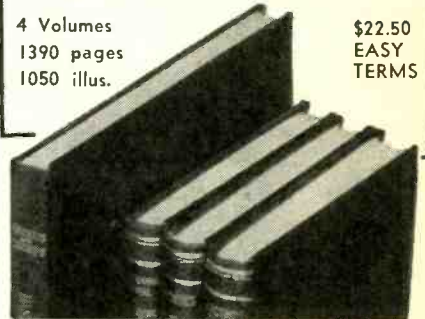

Here's the practical kind of information these 4 volumes give you:

- How to keep the plant's electronic equipment performing as it should
- How to locate and correct tube and circuit troubles quickly and easily
- How to install, service, and maintain even brand new equipment without being stumped by new circuits

No long sessions on math or theory! Instead you get: Clear explanations of how tubes and tube-operated circuits work in motor controls, welding controls, heat controls, etc. A complete manual that covers all maintenance procedures. A handbook of 433 industrial electronic circuits with each fully described. Troubleshooting charts, tested working methods, step-by-step directions—everything you need to start right now is here.

Contains

Chute's Electronics in Industry
Miller's Maintenance Manual of Electronic Control
Markus & Zeluff's Handbook of Industrial Electronics Circuits
Henney & Fahnestock's Electron Tubes in Industry

Shows facts such as:
How to operate the vacuum-tube voltmeter
How to correct ignitor misfire
How to maintain light sources for photoelectric control
How to protect circuits of welding machines
How tubes serve in conveyor synchronization, color measurement, etc. and hundreds more

FREE TRIAL—EASY TERMS

McGraw-Hill Book Co., Dept. RE-8 327 W. 41 St., NYC 36
Send me the Practical Industrial Electronics Library for 10 days' examination on approval. In 10 days I will send \$2.50, then \$4.00 a month until \$22.50 is paid. (A saving of \$3.50 under the regular price of \$26.00.) Otherwise I will return books postpaid. (Print)
Name
Address
City Zone State
Employed by
This offer applies in U.S. only. RE-8

TRY THIS ONE

separately tune the high-C local oscillator with a really good tuning capacitor and dial. These two items cannot be too good. With this sort of arrangement, all that is required to provide both good c.w. and phone coverage for a given band is two plug-in coils for the oscillator, each tapped appropriately for a given degree of bandspread, as shown in Fig. 1. Any standard oscillator circuit may be used, but the vari-

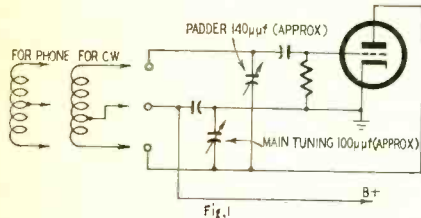

ous forms of the Hartley oscillator lend themselves well to this application. Note that the lower the main tuning capacitor is tapped on the coil, the greater the degree of bandspread. The tapping point for the desired bandspread can be found experimentally.

With a commercial bandswitching receiver using a tracked front end, the problem is different. Since coils cannot readily be tampered with, the solution must be reached via changes in capacitance. If the receiver has a separate bandspread capacitor that does not

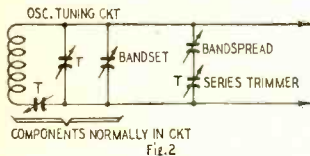

provide enough spread on some bands, you can improve it by connecting a good variable trimmer (an APC type or equivalent) in series with it. Sets that do not have electrical bandspread can be improved by adding a good variable capacitor of about 35 to 50 μf in series with a good ceramic or air trimmer of about 100 μf across the main oscillator tuning gang as shown in Fig. 2. The series trimmer can be set for the desired spread on one band or any portion of it. Additional trimmers can be

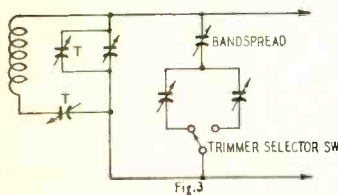

switched in as in Fig. 3 to provide varying degrees of spread for different bands or operating conditions. Some front-end gain is lost if the r.f. and mixer stages tune very sharply, but this will not usually matter if there is sufficient intermediate frequency and audio gain.

Remember that smooth tuning, stable calibration, and good resetability can be obtained only by using the best available capacitors and dial and by rigid mechanical construction. — Wm. Bruce Cameron, W8IVJ

END

irish

BRAND

GREEN BAND Professional



The Finest Tape Your Recorder Can Use...

Just as the reflection of a perfect mirror is faithful to the original image, in every detail, so too does IRISH Green Band RECORD, RETAIN, and REPRODUCE the original sound with flawless fidelity.

Instruments will reveal that IRISH Green Band offers lower noise level, uniform sensitivity, minimum amplitude variation, less distortion. But instrument tests are only the landmarks of good design and production. The final proof is in the hearing. To appreciate the quality of IRISH Green Band Tape, it must be listened to and compared with other tapes on the same recorder.

You will find that the only limitation to IRISH Green Band quality is the limitation of the tape recorder itself... it is the finest tape your recorder can use.



irish GREEN BAND professional

is fast becoming the choice of audio engineers in broadcast stations, recording studios and wherever sound quality is of paramount importance.

1200 feet on plastic reel.....\$3.30
2400 feet on metal or fiberglass reel..... 7.71

One day you will surely use IRISH... so write today for free test sample reel.

irish BROWN BAND
for POPULAR PRICED RECORDERS

IRISH Brown Band, expressly designed for home and office recorders. Reproduces with true fidelity the frequency range from 100 to 8000 cycles. A high quality, plastic base tape for the price of ordinary paper tape!

1200 feet, plastic base, on plastic reel.....\$2.50

At all leading radio parts distributors

ORRADIO INDUSTRIES, INC.

OPELIKA 5, ALABAMA

World's Largest Exclusive Magnetic Tape Manufacturer

EXPORT DIVISION: Morhan Exporting Corp., 458 Broadway, New York, N. Y.

SOUND RECORDING



DO YOU WANT TO WRITE A BOOK?

If you have an idea for writing a book for the Gernsback Library on any phase of electronics, electricity, audio, television, servicing, mathematics, or allied subjects, write today for information on royalties, manuscript payments. Address your letter to:



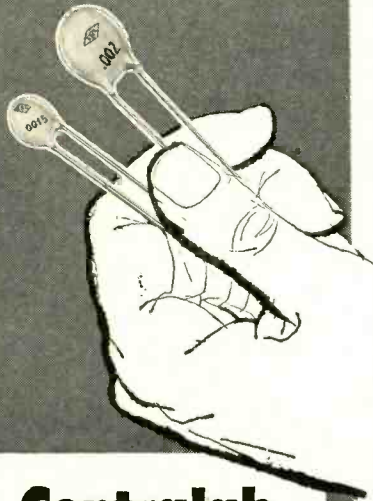

Martin Clifford
Gernsback Publications, Inc.
25 West Broadway
New York 7, N. Y.

SAFER
...and less expensive



Centralab
Type DD 1000-VDCW
Ceramic
Disc Capacitors

Now a complete line of
"standard" disc capacitors —
but look at these advantages

-  There's no danger of an overload blowing out a Centralab DD Disc. Rated 1000 VDCW, every one is 100% tested before shipping — at twice rated working voltage. (2000 VDC)
-  Tolerances are stated honestly. You can install Centralab DD Discs with complete confidence.
-  You can't beat Centralab DD Discs for size or price. They're the smallest possible size—and cost only 12¢ net.
-  Double coating of Durez provides dependable insulation. Centralab DD Discs operate efficiently up to + 85° C.

Play safe — use Centralab 1000-VDCW DD Discs regularly, even when you replace discs under 1000 VDCW. Stock up at your Centralab distributor.

Send coupon for new Centralab Catalog No. 29 for full details on this and many new Centralab developments.

*Trademark

Centralab

D-3554

Tear out coupon and mail today!

CENTRALAB, A Division of Globe-Union Inc.
922-H E. Keefe Avenue, Milwaukee 1, Wis.

Send me new
Centralab Catalog No. 29.

Name.....
Company.....
Address.....
City..... Zone..... State.....

BUSINESS

Merchandising and Promotion

Sylvania Electric Products, New York City, is conducting a three-month

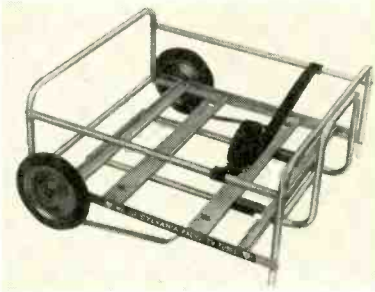

sales promotion campaign for service technicians. The promotion which began June 1 makes it possible for distributors and technicians to acquire an aluminum *Classy Chassis* TV set carrier for a specified amount of orders and sales.

RCA Tube Division, Harrison, N. J., is offering service technicians a free nine-lesson home study course on color television with the purchase of a specified quantity of RCA receiving tubes, between May 1 and November 15, 1954. The course was prepared by RCA Institutes, RCA Laboratories Division, and the RCA Service Company.

Walsco Electronics Corp., Los An-



geles, designed a new point-of-sale display which houses the complete line of Walsco chemicals. The top two shelves have an automatic feed device by which individually spring-loaded tracks automatically slide another bottle forward, after one has been removed.

Pyramid Electric Co., North Bergen, N. J., announced the winners in its \$5,600 prize contest for service technicians in which duplicate awards were given to distributors who serviced the winners. Stanley A. Mol, Dickson City, Pa., service technician, won the top prize of \$2,000. Fred P. Pursell, Scranton, Pa. distributor, won the duplicate award. Second prizes of \$500 each went to Jack E. Burrell and Radio Product Sales Co. both of Los Angeles. Third prize, \$100 each, went to R. Don Weaver and Mid-States Electronic Co., both Chicago.

CBS-Hytron, Danvers, Mass., brought out a new pliers kit which is available free to service technicians with the



purchase of CBS-Hytron receiving tubes from July 1 through August 31.

General Electric Tube Department, Schenectady, N. Y., announced a new "successful service management" program for TV and radio service technicians. This is described in a 318-page loose-leaf binder covering business practices, merchandising, and technical data. The program is available through G-E tube distributors.

General Cement Manufacturing Company, Rockford, Ill. developed a new counter display for its alignment tools. The display may be used as a serve-yourself merchandiser as well as for easier inventory and stock-taking purposes.



Ward Products Corp., Cleveland, is now packaging its automotive antennas in brilliantly colored boxes displayed in floor and counter racks.



Duotone Corp., Keyport, N. Y., is merchandising a new broadcast quality pencil microphone made by Philips of Holland in an attractive green-and-black velvet-lined package.

New 4-Speed Magnemite*

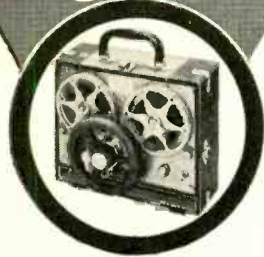

for Unmatched Versatility in Field Recording!

Designed for nature sounds, music, street sounds, interviews, conferences, courtroom reporting, missionary work and field reports. All of these may be recorded on a single 4-speed portable, battery-operated spring-wound tape recorder. Features quick speed change with automatic equalization.

Model 610 EM meets both primary and secondary NARTB standards and operates at tape speeds of 15, 7½, 3¾, 1½ ips. Records and plays back frequencies up to 15,000 cycles. Model 610 DM operates at tape speeds of 7½, 3¾, 1½, ¼ ips.

These tiny recorders weigh only 17 lbs. with self-contained batteries that last 100 operating hours and include built-in monitoring and headphone playback facilities. Designed for extreme simplicity of operation. Meets the most gruelling field tests. May be operated anywhere. Measures only 7 x 10 x 11 inches.

For complete technical information & direct factory prices write to Dept. RE:

AMPLIFIER CORP. of AMERICA

398 Broadway, N. Y. 13, N. Y.

*T.M. Reg. U.S. Pat. Off.

STANDARD COIL PENTODE TURRET TUNER

only

\$13¹⁹

(lots of 3)

\$13.99 each

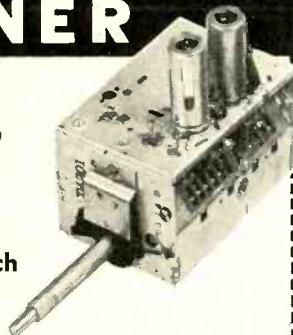

STEVE-EL brings you the tuner used in over 5 million TV sets. Uses a pentode RF amplifier and a dual-triode mixer-oscillator; 25.75 pix IF and 21.25 Mc sound. May be used with either split-sound or inter-carrier as desired. Covers all channels from 2 to 13. Has balanced 300 ohm input.

Supplied with 6J6 and 6AG5 or 6BC5.

FREE!

Write Dept. RE-8 for newest BARGAIN BROCHURE Buy STEVE-EL and SAVE!

EXTRA SPECIAL

16 RP4
PICTURE TUBE
\$16.49

Brand new.
Guaranteed 1 year.

STEVE-EL Electronics Corp.

61 Reade St.

New York 7, N. Y.

BUSINESS

Hallicrafters Co., Chicago, announced the winners in its recent round-the-world sales contest for distributor salesmen. First prize winners were: Roger Duclett of Century-Elcon Distributors, Minneapolis; T. H. Biglieri of Kaemper & Barrett, San Francisco; and Leo Turner of A. F. Epting Appliance Company, Charlotte, N. C. The winners and their wives were awarded a 28-day round-the-world trip.

Federal Telephone and Radio Company, Clifton, N. J., instituted a unique packaging program for merchandising its germanium diodes for replacement use by service technicians. Three packages and two types of dispensers were designed.

John F. Rider Publisher, New York City, designed a new revolving book merchandiser as a sales aid to distributors who handle its books.

Show Notes

The 1954 Western Electronic Show & Convention will be held August 25-27, 1954 in the Pan Pacific Auditorium in Los Angeles. More than 100 high-level technical papers will be presented in approximately 27 separate sessions.

The 1955 IRE Show will once again be held in the Kingsbridge Armory, Bronx, N. Y. on March 21-24.

Calendar of Events

1954 Western Electronic Show and Convention, August 25-27, Pan Pacific Auditorium, Los Angeles, California.

British National Radio Show, August 25-September 4, Earls Court, London, England.

Production and Sales

RETMA reported that 1,904,718 TV sets had been manufactured during the first four months of 1954 compared with 2,827,821 during 1953. In the same period, 3,326,800 radios were manufactured compared with 4,993,720 for the 1953 period.

RETMA reported cathode-ray tube sales by manufacturers at 2,690,519 for the first four months of this year as against 3,705,997 for the 1953 period. 106,026,920 receiving tubes were sold by manufacturers during the first four months of 1954 compared with 163,401,355 in 1953.

New Plants and Expansions

Sylvania Electric Products, New York, announced plans for the construction of a 210,000-square-foot building in Williamsport, Pa., for use by the Radio Tube Division as a centralized packaging area and for finishing operations in tube manufacture. The company has also begun operations in a new 110,000-square-foot warehouse and sales office which it leased in Teterboro, N. J. Several sales and service facilities previously situated throughout the metropolitan New York area have been consolidated in the new building.

General Electric's Heavy Military Electronic Equipment Department will lease two new buildings now under construction in Syracuse, N. Y.

(Continued on page 114)

YOU CAN WIN A NEW FORD!

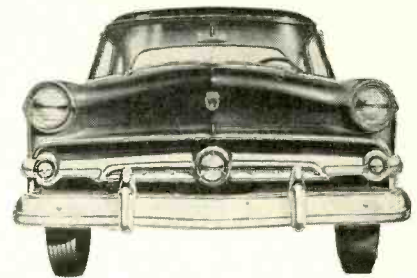

Nothing to buy! Nothing to sell!

Just Illustrate and Explain
a New Application for
International Rectifier Corporation
Selenium Diodes

50 PRIZES

Grand Prize

New Ford V-8 Mainliner Tudor Sedan
and 49 other
valuable prizes

INTERNATIONAL RECTIFIER CORPORATION'S Selenium Diode Application Contest is open to everyone! Here's all you have to do — pick up an official entry blank from your favorite parts distributor. Illustrate and explain a new practical application for International Rectifier Selenium Diodes. Have the entry blank countersigned by your distributor's salesman and then forward it to us before January 1, 1955. Rules and regulations for this contest are included in the entry blank along with helpful hints on selenium diode applications.

JUDGES—Dr. Lee de Forest—United Engineering Labs., Los Angeles, California.
J. T. Cataldo, F. W. Parrish—International Rectifier Corp.

SAMPLE ENTRY

—APPLICATION—

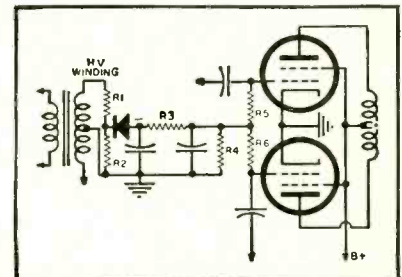

—EXPLANATION—

Typical application for providing fixed bias for push-pull stage of an audio system using International Rectifier Corp. Selenium Diode in conjunction with a voltage divider and filter network... etc., etc.

**DON'T DELAY! ENTRY BLANKS ARE
AVAILABLE FROM YOUR
PARTS DISTRIBUTOR**

CONTEST ENDS JANUARY 1ST, 1955

**INTERNATIONAL RECTIFIER CORP.
EL SEGUNDO, CALIFORNIA**

The new Gernsback Library

helps you learn more—earn more!

SERVICE TECHNICIANS—EXPERIMENTERS!

The more you know about electronics, the more money you can make! GERNSBACK LIBRARY Books offer one of the best ways of keeping up with the new and important in TV, radio and high fidelity. Just one tip from any of these low-cost books may be worth the price of the entire series to you! Check this list of titles and order the books you need today.

TV Repair Techniques— No. 50.

Top technician-writers tell how to recognize, find and correct quickly, the tricky TV servicing problems which stump even the experts. A few minutes reading this book can save you hours of servicing time. 128 Pages. Over 100 Illustrations. **\$1.50**



High-Fidelity—Design, Construction, Measurements— No. 48.

An audio man's audio book. How to get top performance from a high-fidelity system. New 3-way approach. 21 top audio men wrote this book. 128 Pages. Over 100 Illustrations. **\$1.50**



Television Technotes— No. 46.

Cut routine trouble shooting to the bone in TV servicing. Here are the symptoms, causes and cures of over 600 troubles which occur in scores of sets made by leading manufacturers. 128 Pages. **\$1.50**



5 CLASSICS ON RADIO AND AUDIO

- Radio Tube Fundamentals—No. 45**
Theory of receiving tubes from the technician's viewpoint. **\$1.00**
- Model Control By Radio—No. 43**
Theory and practical construction for beginner and expert. **\$1.00**
- High-Fidelity Techniques—No. 42**
A common-sense guide to getting the most out of your equipment. **\$1.00**
- Public-Address Guide—No. 41**
Shows you how to make extra money in profitable PA work. **75c**
- Practical Disc Recording—No. 39**
Theory and practical techniques. Full chapter on each component. **75c**

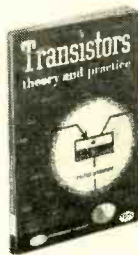

Transistors—theory and practice—No. 51

Rufus P. Turner talks transistors from the viewpoint of the practical man. Transistor applications in well-known circuits! Complete guide to the characteristics of commercial transistors. 144 Pages. 135 Illustrations. **\$2.00**



Radio & TV Test Instruments —No. 49.

How to build just about every instrument required for modern TV-radio servicing. Plus chapters on constructing a practical servicing bench and carrying case. 128 Pages. Over 100 Illustrations. **\$1.50**



Radio & TV Hints—No. 47.

Offers over 300 sure-fire hints, gimmicks, and short cuts on radio, TV and audio. Gathered from the hard-earned experience of experts. Grouped in seven sections. 112 Pages. 132 Illustrations. **\$1.00**



Basic Radio Course— No. 44.

John T. Frye's classic on fundamentals! For the practical man who wants to learn theory. Covers everything from Ohm's Law to advanced servicing in a style which makes learning fun. 176 Pages. Cloth cover. **\$2.25**

From the publishers of RADIO-ELECTRONICS

See your distributor—or mail this coupon

GERNSBACK PUBLICATIONS, INC., Dept. 84
25 West Broadway
New York 7, N.Y.

Enclosed is my remittance of \$.....
Please send me the following books postpaid.

- 39 41 42 43 44 45
 46 47 48 49 50 51

Name.....
(Please print clearly)

Street.....

City..... Zone..... State.....

BUSINESS

Jensen Industries, Inc., phonograph needle manufacturer, moved both its factory and office headquarters to Forest Park, Ill., a west-side suburb of Chicago.

American Phenolic Corp., Chicago, established a Canadian subsidiary, Amphenol Canada Limited, with a manufacturing plant and offices in Toronto, Ont. The company maintained a Canadian branch during World War II.

Sperry Corp., New York City, will build a \$600,000 plant for the development and production of electronic tubes in Gainesville, Fla.

General Instrument Corp., Elizabeth, N. J., organized a Canadian subsidiary, General Instrument — F. W. Sickles of Canada Ltd. which purchased Watt Electronic Products, Ltd., with a plant in Kitchener, Ont.

Micamold Radio Corp., Brooklyn, N. Y. opened the first of two branch factories to be built in Tazewell, Va.

Business Briefs

... Gramer Transformer Corp., purchased Halldorson Transformer Corp., both located in Chicago, according to a joint announcement by James M. Blackledge, president of Gramer, and L. S. Racine, president of Chicago Standard Transformer Corp., the Halldorson parent corporation. Blackledge said that there would be no basic personnel changes in the Halldorson organization and that the line would continue to be available to the distributor trade. Gramer had previously announced its entry into the distributor field with a line of "Tinyformers."

... RETMA has mailed brochures outlining its recommended course for TV technician training to industrial and trade school supervisors throughout the country.

... Raytheon Manufacturing Company, Waltham, Mass., has joined eight other companies in participating in a cooperative electrical engineering course at Massachusetts Institute of Technology. Under the plan MIT engineering students do practical work in the firms' laboratories and factories. Upon graduation they will simultaneously be awarded degrees of Bachelor of Science and Master of Science.

... NEDA's Board of Directors recommended the appointment of a committee to investigate the possibilities of cooperative buying.

... Tele-Matic Industries, Brooklyn, N. Y., which has filed for an arrangement under Chapter XI of the Bankruptcy Act, is continuing operations, with a greater concentration of its line of TV accessories planned.

... NEDA Board of Directors recommended a constitutional change whereby new members would be admitted to the association without the present requirement that they be in the distributor business for two years.

... Channel Master Corp., Ellenville, N. Y., has negotiated with Nikoh Tube Co. to market its Tele-Tube welded steel tubing for TV masts. END

PEOPLE

Ralph L. Weber, secretary of Gramer Transformer Corp., Chicago, was named executive vice-president. He also retains his position as secretary. **Burt Anderson**, former general sales manager, was promoted to vice-president in charge of sales. **Fred R. Cooper**, former chief engineer, was elected vice-president in charge of engineering.



Ralph L. Weber

Allen J. Dusault was appointed sales manager of the Transistor Division of CBS-Hytron, Danvers, Mass. He has had over ten years experience in sales and advertising in the electronics field.



A. J. Dusault

Marshall L. (Mike) Remund was named jobber sales manager of Jensen Industries, Chicago. He will co-ordinate sales and merchandising programs from the factory to Jensen representatives and their parts jobber accounts.



M. L. (Mike) Remund

Charles Golenpaul, vice-president in charge of distributor sales of Aerovox Corporation, New Bedford, Mass., was



R. Triplett (left) and **C. Golenpaul**, elected president of "Radio's Old Timers." **Sam Poncher**, president of Newark Electric, Chicago, became secretary of the organization. **Ray L. Triplett**, founder and president of Triplett Electrical Instrument Co., Bluffton, Ohio, the retiring president of Radio's Old Timers, was presented with a plaque as a testimonial to his service to the industry and the organization. **Thomas C. Soby** was named advertising and sales promotion manager of

OPPORTUNITY ADLETS

Rates—45c per word (including name, address and initials). Minimum ad 10 words. Cash must accompany all ads except those placed by accredited agencies. Discount, 10% for 12 consecutive issues. Misleading or objectionable ads not accepted. Copy for Oct. issue must reach us before Aug. 16, 1954.

Radio-Electronics, 25 W. Broadway, New York 7, N. Y.

PASS AMATEUR THEORY EXAMS. CHECK YOURSELF with sample FCC-type questions and novice and general class examinations. All for only 50c. American Electronics, 1203E Bryant Ave., New York 59, New York.

SPEAKER REPAIRS ON ALL MAKES. 8" & 12" HI-FI speakers for sale. Amprite Speaker Service, 70 Vesey St., New York 7, N.Y.

REPAIR ON ALL MAKES of test equipment, and kit construction, starting September First. Write now for free information. Bigelow Electronics, Pioneer Road, Beulah, Michigan.

DIAGRAMS FOR REPAIRING RADIOS \$1.00. Record Changers \$1.50. Television \$2.00. Give Make, Model. Diagram Service, 672-RE, Hartford 1, Conn.

TEST EQUIPMENT repaired and Calibrated by Factory staff. All makes. Superior, Simpson, Triplet, Heath, etc. Immediate service. Douglas Instrument Laboratory, 176a Norfolk Avenue, Boston 19, Mass.

TUBES—TV, RADIO, TRANSMITTING, AND SPECIAL PURPOSE TYPES BOUGHT AND EXCHANGED. Send details to B. N. Gensler W2LNI, 136 Liberty, N. Y. 6, N. Y.

ALL MAKES OF ELECTRICAL INSTRUMENTS AND TESTING equipment repaired. Write for free catalogue on new and used instruments at a savings. Hazleton Instrument Co., 128 Liberty Street, New York, N. Y.

BUILD YOUR OWN ELECTRONIC ORGAN, OR MINIATURE electronic brain. Jim Kirk, W6JKX, 1552 Church Street, San Francisco 14, California.

WANTED: AN/APR-4, other "APR.", "TS-1", "1E-1", ARC-1, ARC-3, ART-13, BC-348, etc. Microwave Equipment. Everything Surplus. Special tubes. Tec Manuals, Lab Quality Equipment. Meters. Fast Action. Fair Treatment. Top Dollar! Littell, Fairhills Box 26, Dayton 9, Ohio.

ALUMINUM TUBING, Angle and Channel. Plain and Perforated Sheet. Willard Radcliff, Fostoria, Ohio.

RECORDS—25-50% DISCOUNT on guaranteed factory fresh LP records; LP records 60c and up; pre-recorded tape. Send 20c for complete LP catalogue. SOUTHWEST RECORDS, 4710 Caroline, Houston 4, Texas.

TELEVISION RECEIVERS \$30 UP. W4API, 1420 South Randolph, Arlington 4, Virginia.

BASS-REFLEX ENCLOSURES \$19.95 up. Buy Direct. Send for Literature. Velvet-Voice Enclosures, Box 472, Fontana, California.

TV FM ANTENNAS. ALL TYPES INCLUDING UHF. Mounts, accessories. Lowest prices. Wholesale Supply Co., Lunenburg 2, Mass.

HOTTEST SALE EVER! in TV and Radio Parts

Everything brand new and guaranteed, we are overstocked, as much as 90% off on some items

SHOWROOM SAMPLES #630 TV CHASSIS, standard brand, Complete ready to play. (less CRT) \$99.97	TV CHEATER CORDS, with both plugs 19c	TV CONICAL ROOF ANTENNA, NA, quick-rig, only \$2.89
\$79.95 FORD AUTO RADIO, 1952 or 53, custom built, automatic tuning complete, ready to install \$46.72	TV WIRE WOUND RESISTOR, 5300/2-500 ohms, only 16c	TV CONICAL ROOF ANTENNA, double stacked array, only \$4.97
\$79.95 CHEV. AUTO RADIO, 1951 or 52, custom built, automatic tuning complete, ready to install \$46.72	QUARTER AMP FUSE only 2c	TV CORONA BUTTONS, for IIV socket assembly, only 1c each
\$59.95 HUDSON AUTO RADIO, custom built for any model from 1948 to 1954, complete \$32.18	G.I. PHONO. ELECTRIC MOTOR complete with turntable \$2.38	PLASTIC SPRAY IN HANDY CANS, lacquer, aluminum or pine, only 69c each
\$59.95 HENRY J. AUTO RADIO, 1951 or 52 custom built, complete \$32.18	STANDARD VARIABLE CONDENSER, 460/162mmf. only 59c	TV 60° DEFLECTION YOKES, only 69c
\$39.95 UNDERDASH AUTO RADIO, fits any car, complete \$22.84	IF TRANSFORMER (AM) 456kc, only 34c	GE AGC-WIDTH COIL, finest type, 39c
\$49.95 REGENCY UHF CONVERTER #RC-600, best made, complete \$29.97	IF TRANSFORMER (FM) 10.7mc, only 49c	AUTO RADIO VIBRATOR, 4 prong non-synchronous type \$1.19
UHF STRIPS FOR STANDARD TUNER F-24, 25, 27, 28, 33, 34, 38, 39, 45, 46, 48, 54, 71, 73, K-17, 24, 28, 34, 39, 45, 48, 57, 59, 61, 73 — also Q-45, your choice \$3.99	AUDIO OUTPUT TRANSFORMERS, 50L4-39c; 6K6-49c	TV GUY WIRE AUTOMATIC FASTENER, only 7c
\$39.95 PHILCO TV BOOSTER, complete in sealed cartons only \$9.98	SELENIUM RECTIFIERS, 100ma-68c; 175ma-76c	ESICO ELECTRIC SOLDERING IRON, 100 watts, only \$1.98
\$22.00 TV POWER TRANSFORMER, 250ma good for many TV SETS, only \$4.97	FINEST PM SPEAKERS, 4"-98c; 5"-\$1.14; 12"-\$4.96	TV ION TRAPS, type for all TV's, 16" to 24", only 29c
RCA FLYBACK TRANSFORMER #218T1, doubler type, operates 16" to 24" CRT's only \$1.67	6 FOOT LINE CORD with PLUG, fine quality 14c	
TV VERTICAL OUTPUT TRANSFORMER, 10 to 1 ratio, good for most SETS. Slashed to 99c	ELECTROLYTIC SUB CHASSIS PAN, for most TV Sets, only 19c	
CRT TV SOCKETS w/18" LEADS 19c	#630 PUNCHED CHASSIS PAN, complete with all sockets, only \$6.56	
TV 300 OHM TRANSMISSION WIRE, 100 ft. roll 98c	TV FILTER CHOKES 62 OHMS, only 99c	
TV 72 OHM CO-AXIAL CABLE 100 ft. roll \$3.58	TV SOUND IF TRANSFORMER #201R1, only 68c	
TV CONDENSERS HV (Cartwheels) 10kv-500v 16c 20kv-500v 39c	VIDEO PEAKING COILS, #203L1, 203L2, 203L3, 203L4, only 9c each	
TV KINESCOPE LEADS 18" only 19c	TV CONVERTER COIL, only 39c	
TV OPEN MASKS 16"-29c; 17"-89c; 21"-\$1.99	TV HEIGHT CONTROL, 2.5 meg, only 22c	
DUMONT TV FRONT END TUNER, complete with tubes \$16.94	TV HORIZ. DRIVE CONTROL, 20k ohms, only 14c	
ORTHOSONIC AC-DC RADIO, complete with 4 tubes \$7.95	TV HORIZ. TRIMMER, 40-103mmf. only 19c	
	TV ELECTROLYTIC CONDENSERS, 40/10-10-450/450/350v. 80/50mmf - 450/450v 79c each	
	TV WIDTH CONTROL COIL #201R4, only 12c	
	ELECTROLYTIC CONDENSER, 8mf-450v, only 24c	
	RADIO TUBULAR CONDENSERS .1-200v, .002-200v, .006-400v only 3c each	
		BEST BUYS IN HANDY ASSORTMENTS
		Top quality and desirable sizes, don't confuse these offers with useless merchandise or foreign type resistors sold at supposed to be low prices.
		100 ASSORTED TUBULAR CONDENSERS, \$15.00 value, only \$3.69
		100 ASSORTED 1/2 WATT RESISTORS \$2.97
		15 ASST. RADIO ELECTROLYTIC CONDENSERS \$3.74
		15-ASSORTED TV ELECTROLYTIC CONDENSERS \$5.88
		100 ASSORTED MICA CONDENSERS \$3.99
		100 ASSORTED CERAMIC CONDENSERS \$3.99
		100 ASSORTED 1 WATT RESISTORS \$4.86
		100 ASSORTED SOCKETS, Octal, Loctal & Miniature \$2.92
		100 ASSORTED KNOBS, Screw & Push-On \$2.97
		10 VOLUME CONTROLS, assorted with switch 1/4, 1/2, 1, 2 meg., and others \$2.94
		FREE with each order Resistor & condenser code charts

BROOKS

84 Vesey St.
New York 7, N.Y.

For Fact Action,
CALL Cortlandt 7-2359

PEOPLE

... William P. Short was appointed general manager of the Electronics Division of Gabriel Company, Norwood, Mass. He will also continue his position as assistant to the president of the parent firm.

... Joseph T. Zuravleff has been transferred to the Chicago District Sales office of Erie Resistor Corp. He was formerly a sales correspondent in the home office in Erie, Pa.

... J. R. Pittle joined U. S. Wire & Cable Corp., Union, N. J., as sales manager. He was formerly an executive with a wire mill in the Metropolitan New York area.

... Joseph Roche joined CBS-Columbia, Service Department, Long Island City, N. Y., as publications manager. He formerly held a similar position with Allen B. Du Mont Laboratories. Roche is co-author of the Video Handbook and the Radio Data Book.

... John Hoder has been promoted to art director of the Ward Products Division of the Gabriel Company, Cleveland, Ohio.

... Henry G. Baker, vice-president of RCA and general manager of the Instrument Department, will now serve as vice-president and general manager of the newly formed RCA Victor Television Division. James M. Toney, former director of distribution of consumer products, was appointed general manager of the new RCA Victor Radio and Victrola Division.

... Daniel Echo was named to head the newly formed sales office for industrial cathode-ray tubes of the Technical Sales Department of Allen B. Du Mont Laboratories established at the cathode-ray tube plant in Clifton, N. J. He has been with the company for the past three years. Robert H. Dolbear heads a similar office for multiplier photo-tube sales in the Du Mont tube manufacturing plant in Passaic, N. J. He was formerly field service engineer for the Electronic Division of the Curtiss-Wright Corp.

... Joseph Weinberg was named purchasing agent for Industrial Television Inc., Clifton, N. J. He was formerly with Boonton Radio Corporation.

... Donald E. Smith was appointed Midwestern District Sales Manager for CBS-Hytron, with headquarters in St. Louis. He will handle sales of CBS-Hytron radio and TV tubes in Missouri, Kansas, and portions of Illinois and Indiana.

... Stanley W. Horrocks was named general manager of the Special Products Division of Aerovox Corp., New Bedford, Mass. He was formerly with RCA.

... Jerome R. Meltzer was promoted to assistant sales manager of the new Distributor Sales Department of the Semi-Conductor Division of Radio Receptor Co., New York, N. Y. He was formerly a sales engineer for the company. END



"Boy... Have I Got the Lines!"

You, too, can have the lines—that meet your exact leadline conditions — whether you are a TV Set Dealer or Service Organization making the finest television reception installations, or a TV fan that demands sharp, "SNOW-FREE" pictures.

We specialize in the manufacture of television transmission lines — built with only one idea in mind: "THE FINEST TELEVISION RECEPTION!"

For UHF and VHF

"SHEATH-LEED" — the all-weather leadline for the toughest conditions: Salt spray in coastal areas; hot, humid weather, or for frosty, icy, wintry wind-whipping conditions which impose a severe tax... Pure Polyethylene Tubing encasing Standard GOODLINE AIRLEAD.

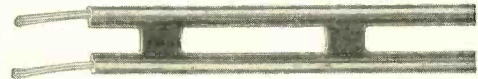

"GOODLINE" AIRLEAD — standard of leadline excellence — with 80% of the loss producing web removed. Correct impedance for sharp, "snow-free" pictures. Of pure polyethylene with flexible stranded copper-clad conductors. MANY IMPORTANT FEATURES.

NEW FULL-WEB "SHEATH-LEED" — the pure polyethylene of "SHEATH-LEED" and full characteristics of GOODLINE AIRLEAD — but NO PERFORATED WEB. No 20 (7 strand 28) copperweld wire in pure electronic golden clear polyethylene — with a pure silver-gray polyethylene sheath overall — for Maximum Weather Protection.

Don Good, INC.

SOLD BY LEADING
JOBBER & DEALERS

Send coupon NOW!
Get samples "in your hands"
—you'll realize why
Don Good Products make
the finest television
reception possible.

DON GOOD, INC. 1-16
1014 Fair Oaks Ave., So. Pasadena, Calif.
Please rush Samples and Complete Information covering Don Good Products.

Name _____
Street _____
City _____ State _____

EASY TO LEARN CODE

It is easy to learn or increase speed with an Instructograph Code Teacher. Affords the quickest and most practical method yet developed. For beginners or advanced students. Available tapes for beginner's alphabet to typical messages on all subjects. Speed ranges 5 to 40 WPM. Always ready—no QRM.



ENDORSED BY THOUSANDS!

The Instructograph Code Teacher literally takes the place of an operator-instructor and enables anyone to learn and master code without further assistance. Thousands of successful operators have "acquired the code" with the Instructograph System. Write today for convenient rental and purchase plans.

INSTRUCTOGRAPH COMPANY

4701 Sheridan Rd., Dept. RC, Chicago 40, Ill.

RECEIVING TUBES

BRANDED-INDIVIDUALLY BOXED
GUARANTEED 6 MONTHS

A Few Summer Bargains

125A7GT \$.58	1B3GT \$.72
125K7GT60	6AUG45
125Q7GT56	6BAG40
3Z5GT50	6BE640
50L6GT59	6X442

(Write for types not listed)

TERMS: 25% with order, balance COD. Orders over \$15.00, with full remittance, prepaid to you in Continental U.S.A. Prices subject to change without notice. Minimum Order \$5.00.

DORIAN Electronics Corp.
89-39 163rd St., Jamaica 32, N.Y.

IDEAS that will help you move ahead and make more money!



RADIO - ELECTRONICS

**A few of the features you won't want to miss
in next month's issue and the issues ahead!**

- **TECHNIQUES FOR SERVICING PRINTED WIRING**
This type of circuit is becoming increasingly more common. This article describes the methods of handling it and the pitfalls to be avoided.
- **A NEW TRANSISTOR AM OSCILLATOR**
A pocket-size battery-operated transistor oscillator which generates four spot frequencies at 455 kc, 600 kc, 1 mc and 1.4 mc for testing and servicing AM receivers.
- **DESIGN AND CONSTRUCTION OF A PIN-JACK MULTIMETER**
This new pocket tester will measure currents down to a few microamperes.
- **ADDING AUTOMATIC FREQUENCY CONTROL TO YOUR FM TUNER**
Some of the older receivers and a few newer ones tend to drift. AFC will prevent that.
- **TRANSISTORS FROM N TO P**
Another installment in this stimulating series on transistors.
- **VERTICAL INTERLACE AND INSTABILITY PROBLEMS**
One of our most authoritative authors is writing about horizontal instability. Matt Mandl will cover vertical interlace in another article.
- **A VERSATILE UTILITY AMPLIFIER AND SIGNAL TRACER**
This little instrument besides being useful for trouble shooting a set, is also a good audio unit for the bench.

YES—I want to Move Ahead and Make More Money

Please enter my subscription to RADIO-ELECTRONICS as checked below under your NO RISK offer and send me as a free gift the COLOR TV SERVICING GUIDE.

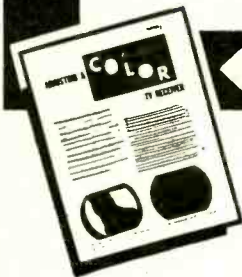

← FREE VALUABLE TV SERVICING GUIDE

... yours as a gift with your subscription to RADIO-ELECTRONICS if you send payment NOW!

DON'T MISS A SINGLE ISSUE—subscribe today and SAVE MONEY. JUST GIVE THIS COUPON to your magazine agent or mail it direct to us.

YOUR NO RISK GUARANTEE
If at any time you do not feel that RADIO-ELECTRONICS is a real help to you. Just tell us so and we will promptly refund the unused portion of your subscription. You may keep the TV service guide as a gift. Fair enough? We want you to be the sole judge.

PLEASE CHECK:

- One Year—12 big issues—\$3.50
(SAVING ME 85c over the single copy price)
- Or you may prefer:
- 3 Years—36 big issues—\$8.00
(SAVING ME \$5.05 over the single copy price)
- 2 Years—24 big issues—\$6.00
(SAVING ME \$2.70 over the single copy price)
- I enclose \$..... Please bill me.

NAME (Please Print Clearly)

ADDRESS

CITY ZONE STATE 84

**MAIL TODAY TO: RADIO-ELECTRONICS
25 West Broadway, New York 7, N. Y.**

ELECTRONIC LITERATURE

Any or all of these catalogs, bulletins, or periodicals are available to you on request direct to the manufacturers, whose addresses are listed at the end of each item. Use your letterhead—do not use postcards. To facilitate identification, mention the issue and page of RADIO-ELECTRONICS on which the item appears. All literature offers void after six months.

TUBE BROCHURES

General Electric has issued four new brochures on tubes. One deals with recommended types for AM and FM television receivers, giving characteristic reference charts as well as an interpretation of technical data.

Another brochure describes *Five-Star* tubes which are high-reliability receiving types for any critical application. Essential characteristics of the entire line is included in convenient chart form.

Lighthouse tubes for dependable v.h.f. and u.h.f. performance are described in another brochure which features technical data on the GL-2C89-B and essential characteristics on a complete line of lighthouse tubes.

Another brochure describes the GL-6265—A *Five-Star* version of the 6BH6.

Available gratis from General Electric, Tube Department, Schenectady 5, N.Y.

GERMANIUM DIODES AND TRANSISTORS

Radio Receptor Co., Inc., has issued an 8-page catalog, Bulletin No. G-23, which describes their complete line of germanium diodes and germanium transistors. The catalog is fully illustrated with charts, voltage curves, and diagrams, and lists product applications. Thirty-two different germanium diodes are listed, including four JAN types and nine hermetically sealed diffused p-n-p junction transistors.

Available upon request to the Sales Department, Radio Receptor Co., Inc., 251 West 19 Street, New York 11, N.Y.

ANTENNA CATALOG

Miller Television Co. has put out a new catalog showing over 400 antenna models and over 100 accessory items. Among the models described are bi-focal, v.h.f. and Yagi types.

Available gratis from Miller Television Co., 2840 Naomi, Burbank, Calif.

RADIO AND TV COILS

J. W. Miller Co. has put out 32-page catalog No. 55. It describes television components and coils, adjustable r.f. coils and chokes, FM and v.h.f. components, i.f. transformers, all-wave coils, radio interference filters, receiver-coil kits, and other radio accessories. A complete index and price list of all the equipment described is given.

Available gratis from J. W. Miller Co., 5917 S. Main Street, Los Angeles 3, Calif., and distributors.

ELECTRONIC LITERATURE

ANTENNAS AND ACCESSORIES

Channel Master Corp. has issued a 16-page loose-leaf catalog which illustrates and describes both v.h.f. and u.h.f. antennas, masts, towers, mounts, inter-action filters, and general accessories. Most of the antenna information is supplemented by technical data, including gain curves, horizontal polar patterns, etc.

Available free from Channel Master Corp., Ellenville, New York.

PLASTIC FILM CAPACITORS

Electronic Fabricators, Inc., has announced the availability of their 4-page Technical Publication 154 which contains complete information on the EFCON type MH miniature plastic film close-tolerance capacitors. This two-color bulletin contains complete descriptions, specifications, dimensions, test data, and characteristic curves for the MH capacitors.

Available free on request to Electronic Fabricators, Inc., 682 Broadway, New York 12, N. Y.

HI-FI RESISTORS

International Resistance Co. has issued an 8-page catalog No. F-1. Forty-three different types of MP high-frequency resistors are described, giving their characteristics, construction, individual specifications, applications, and installation. The catalog includes photos, charts, and graphs.

Available free from International Resistance Co., 401 N. Broad Street, Philadelphia, Pennsylvania.

PANEL LAMP CHART

United File-O-Matic, Inc., has issued a panel lamp chart which is numerically arranged and is a composite listing of all panel and flashlight lamps manufactured by General Electric, National Carbon, Radio Corporation of America, Raytheon, Sylvania and Tung-Sol. Simply by checking the lamp number on the chart the following information becomes available: manufacturer, bulb type, base, volts, amps, and bead color. All bulb types are illustrated with physical dimensions.

Available free from United File-O-Matic, Inc., 106 Lafayette St., New York 13, N. Y.

QUARTZ CRYSTALS

General Electric Co. has announced the publication of a new 6-page booklet entitled *Quartz Crystals* which contains all pertinent information needed for ordering quartz crystals. Such variables as crystal holder type, temperature range, frequency tolerance over temperature range, and calibration are shown in the tables.

Available free on request to the General Electric Co., Germanium Products, Electronics Park, Syracuse, N. Y. END

200 POUNDS

on a 10 foot television mast
PERMA-TUBE supports it safely!

Place a 10 foot length of 1 1/4" x 16 gage (.065") wall Perma-Tube between two tables so that 6 inches rests on a table at each end. Place a 200 pound weight at the center point.

What happens? Tests prove that Perma-Tube will support this 200 pound weight with a minimum of deflection and permanent set.

Other materials show serious degrees of permanent set. Why? Because they are not made from the special strength J&L steel that is used to form Perma-Tube Television Masts. And too, Perma-Tube is coated with a metallic vinyl resin—inside and out.

What do the strength and corrosion-resistance of Perma-Tube mean to you? They mean protection for your work and your customers. Freedom from damage due to storms . . . better reception from the sets you install . . . insurance for your reputation . . . increased business and profits for you.

Only GENUINE Perma-Tube supports 200 pounds with a minimum of permanent set... accept no claims from substitute materials. Look for this Perma-Tube Brand.

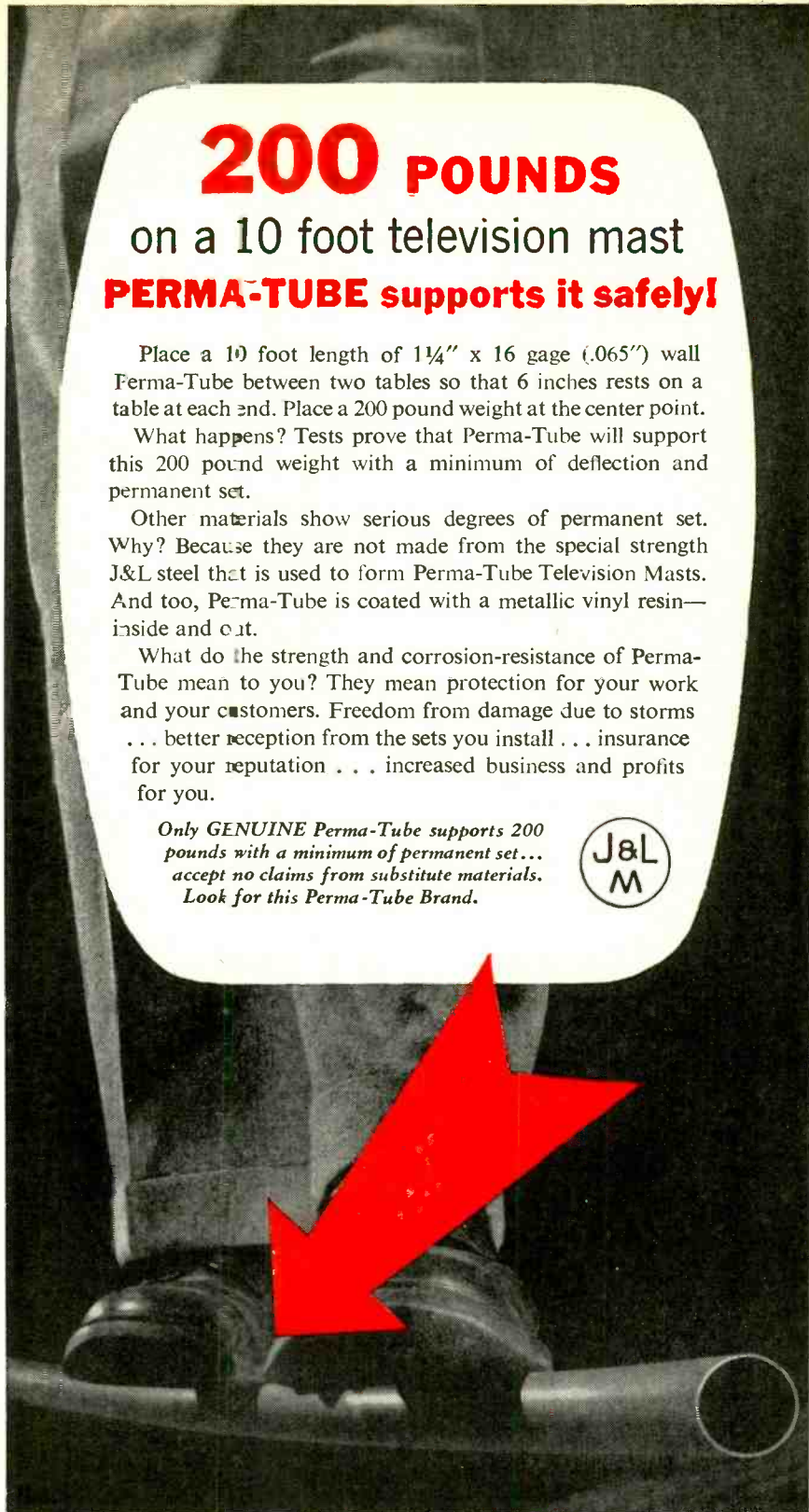

Make this test yourself. Compare Perma-Tube with any other masts—steel or aluminum.



Jones & Laughlin
STEEL CORPORATION — Pittsburgh

Color Servicing

IS NOW IN THE FAMOUS

Mandl's TV Servicing



The new section on color servicing and color circuits gives you the same clear how-to-do-it instruction that has made this book a favorite with servicemen everywhere. You'll be FULLY prepared to service any set, do the best job of installation or trouble shooting in minimum time, either for color or for black and white.

EASY to learn

Simple, clear explanations show you how each unit in the TV receiver functions, with lists of the flaws that may occur in it, what points in the circuitry cause them, how they affect other components, how they show up on the TV screen. Every step is fully illustrated with large clear schematics, photographs of test patterns, scope patterns and other helpful illustrations.

How to locate trouble quickly

A complete master trouble index gives the possible causes of distortions or faults in picture or sound, with references to the pages on which servicing instructions are given. You can quickly and easily diagnose the source of trouble and know just what to do about it.

Methods used by experts

You'll learn the practical time-saving methods used by the most experienced servicemen and technicians:—ways of locating those hard-to-find troubles, simple signal tracing procedures, how to improve reception in fringe areas, how best to use test equipment. You'll learn the necessary why's and wherefore's of TV reception, but won't be confused by unnecessary theory or involved math—just what you need in order to do a skilled servicing job is given here.

Recent improvements

In addition to the instruction on color—how it works, how to service color sets—you'll have the latest data on such improvements as cascade tuners, automatically focused tubes, new types of high frequency I.F. systems, transistors, UHF-VHF receivers. You'll learn TV for today and TOMORROW from this book.

Look it over without obligation. See for yourself how easy and practical this book is—how quickly you'll become expert with it, how useful it is on any job. Get a copy on

10-day FREE TRIAL

THE MACMILLAN COMPANY,
Dept. RE-5
60 Fifth Avenue • New York 11

Please send me a copy of the new Mandl's TV Servicing. I will either pay the full price of \$5.75 plus a small delivery charge or return the book in 10 days. (SAVE: send check or money order and we pay delivery charge.)

Signed _____

Address _____

This offer good only within continental limits of U.S.A.

BOOK REVIEWS

TELEVISION SERVICING COURSE, compiled by M. N. Beitman. Published by Supreme Publications, 1760 Balsam Road, Highland, Ill. 8½ x 10¼ inches, 192 pages. Price \$3.00.

The author's aim in preparing this book is aptly told in the subtitle "Practical Television Training for Home-Study." It is not a fix-it-yourself book for the unskilled. The author assumes a working knowledge of radio servicing techniques and instruments and has slanted the material to enable persons with such knowledge to get into practical TV servicing in a minimum of time.

The first eight lessons (chapters) introduce the reader to basic television theory and practice. They discuss the basic TV receiver with general descriptions of the purpose and functions of the various circuits and controls.

Lessons 9 through 14 consist of a well-correlated compilation of technical service information abstracted from service literature prepared and issued by the leading TV receiver manufacturers. The selection of material is such that the reader gets detailed discussions on the operation of almost every type of circuit used in modern TV sets, and detailed alignment instructions on four popular TV receivers. In this group are splitcarrier and intercarrier sets with 25- and 45-mc i.f.'s. The detailed circuit analyses given here are far more valuable to the novice TV technician than the uneven coverage which so many modern authors give to complex TV circuitry. The trend in many modern TV servicing manuals and texts seems to be to discuss some types of circuits in great detail and ignore or pass over others.

The novice TV service technician will find this book a worthwhile introduction to circuit complexities of, and servicing techniques for, modern TV sets. The experienced TV technician will find it a quick and easy way to master the theory of the many circuit developments and variations now used by set manufacturers.—RFS

HOW TO INSTALL & SERVICE AUTO RADIOS, by Jack Darr. 5¾ x 8¼ inches, 116 pages. Price \$1.80. **SPECIALIZED AUTO RADIO SERVICE MANUAL**, Volume 1-A. 8½ x 11 inches, 182 pages. Price \$3.00. Both books are published by John F. Rider Publisher, Inc., 480 Canal St., New York 13, N. Y.

Darr has done an excellent job of introducing to the service technician with limited experience on automobile installations the problems of installing and servicing auto radios. He does not pretend to give the reader a general course in radio servicing or to tell him which ear to lie on while flat on his shoulders working under an automobile's dashboard, but he does answer many questions of importance.

His book is divided into three sections. The first, "Installing Auto Radios," discusses antenna types, control heads, techniques and procedures

BLAK-RAY SELF-FILTERING ULTRA-VIOLET LAMP



BLAK-RAY 4-watt lamp, model X-4, complete with U-V tube. This lamp gives long-wave ultra-violet radiation having a wave-length of 3654 to 4000 angstrom units. Some of the substances made to fluoresce visibly when illuminated by U-V light are certain woods, oils, minerals, milkstone, cloth, paints, plastics, yarn, drugs, crayons, etc. This lamp is self-filtering and the invisible U-V rays are harmless to the eyes and skin. Equipped with spectral-finish aluminum reflector. Consumes only 4 watts and can be plugged into any 110 volt 50-60 cycle A.C. outlet. Will give 2000 to 3000 hours of service. It weighs but 1¼ lbs. Approved by the Underwriters Laboratories and has a built-in transformer so that it may be safely used for long periods when necessary. Extra U-V tubes are available.

Ship wt. 4 lbs. **\$16.75**
ITEM NO. 125
UNUSUAL BUY (Shp. Chgs. 70c)

POWERFUL ALL PURPOSE MOTOR



Sturdy shaded pole A.C. induction motor. 15 watts, 3000 rpm. 3"x2"x1¾"; 4 mounting studs; 7/8" shaft, 3/16" diameter; 110-120 volts, 50-60 cycles. A.C. only. When geared down, this unit can operate an 18" turntable with a 200 lb. dead weight. Use it for fans, displays, timers and other purposes. Ship wt. 2 lbs. **\$2.45**
ITEM NO. 147
UNUSUAL BUY (Shp. Chgs. 35c)

WATTHOUR METER

Leading makes—reconditioned. Ideal for trailer parks. 100-110 volts, 60 cycles, 2-wire A.C. 5 amp. Heavy metal case 8½" x 6¼" x 5". Easy to install. Ship. wt. 14 lbs. **\$4.50**
ITEM NO. 33
NOW ONLY (Shp. Chgs. \$1.25)



WESTERN ELECTRIC BREAST MIKE



Lightweight 1 lb. carbon microphone. Aircraft type. Breastplate mounting, adjustable 2-way swivel. Easily fastened straps. For home broadcasts, communications etc. Complete with 6 foot cord, hard rubber plug. Sherardized plate, non-rusting finish. Ship. wt. 2 lbs. **\$1.98**
ITEM NO. 152
NEW LOW PRICE (Shp. Chgs. 32c)

AMAZING BLACK LIGHT



250-watt ultra-violet light source. Makes fluorescent articles glow in the dark. Fits any lamp socket. For experimenting, entertaining, unusual lighting effects. Ship. wt. 2 lbs. **\$2.45**
ITEM NO. 87
A SAVING AT (Shp. Chgs. 35c)

250 POWER TELESCOPE LENS KIT

Make your own high powered 6 ft. telescope. Kit contains 2" diam., 75" focal length, ground and polished objective lens and necessary eye pieces. Magnifies 50x to 250x. Full instructions. Ship. wt. 1 lb. **\$2.95**
ITEM NO. 123
YOU SAVE AT (Shp. Chgs. 10c)

HUDSON SPECIALTIES CO.
25 West Broadway, Dept. RE-8-54
New York 7, N. Y.

I am enclosing full remittance for items circled below. (Be sure to include shipping charges.)
OR, my deposit of \$_____. SHIP balance C.O.D.
MINIMUM C.O.D. ORDER \$5.00.
C.O.D. ORDERS ACCEPTED ONLY WITH 20% DEPOSIT
INCLUDE SHIPPING CHARGES.

Circle Items Wanted
87 147 33 152 125 123

Name _____ Please Print Clearly

Address _____

City _____ Zone _____ State _____

BOOK REVIEWS

for eliminating noise by bonding, bypassing, and suppressing; speaker installations, and special techniques and practices for making installations in commercial vehicles such as trucks and buses.

The second section of the book is devoted to special servicing and troubleshooting methods that apply directly to auto radios. The power supply, speakers, tuning mechanisms, spark plates, realignment techniques, and preventive maintenance are discussed adequately enough to help considerably those service technicians who lack auto radio experience.

"The Auto Radio Service Shop" is the concluding section. It covers special alignment and hand tools, test instruments, parts inventories and business records and concludes with a discussion on earning and holding customer respect and good-will, essential to the success of any business.

Darr's simple matter-of-fact style makes his material easy to read and to understand. All pertinent points are adequately illustrated with photos and drawings.

The Specialized Auto Radio Manual is a useful addition to the library of a radio service shop handling auto radios. It consists entirely of manufacturer's diagrams and service and installation information on radios used in Ford, Lincoln, and Mercury automobiles—1950 through 1954.—RFS

THE WEAR AND CARE OF RECORDS AND STYLI, by Harold D. Weiler. Published by Climax Publishing Co., 17 East 48th St., New York 17, N. Y. 5 x 7 inches, 56 pages. Price \$1.00.

The weakest link in the entire chain of a high-fidelity system is the stylus. Costing less than any other reproducing component, misuse of the stylus leads to unnecessary record wear and destruction of the very thing for which a high-fidelity setup is designed—high fidelity. Based upon his personal experience and investigation the author has a number of suggestions on stylus life and record care.—MC END

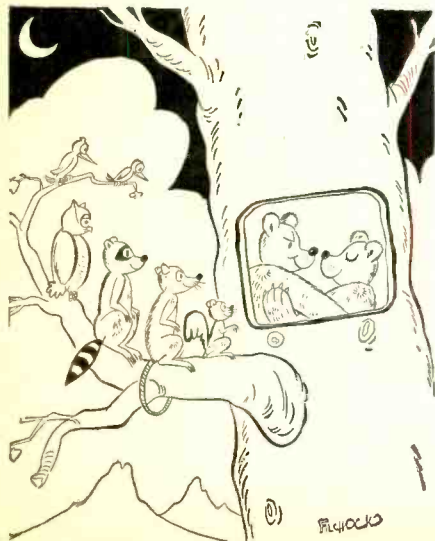

AUGUST, 1954

"Better than Originals!"

THIS IS Plaskoil

**THE NEW PLASTIC-COATED
H. V. COIL WITH
4-WAY
BETTER PROTECTION!**

**NO INCREASE IN PRICE
FOR THIS PREMIUM FEATURE**

FB414, FB415—Above, specific replacements for over 100 Emerson TV Models and Chassis.

More PLASKOIL units now available

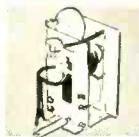

FB412—Specific replacement for 83 Airline, Raytheon, and Truetone models.

FB410—Multi-purpose flyback with AGC winding and universal mounting.

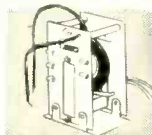
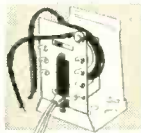

FB401—Widely used G.E. Type replacement flyback.



FB404—Direct-Drive replacement flyback for RCA, Capehart, Emerson, etc.



RF800—Horizontal Width-Linearity Coil with AGC winding.



First again with the latest—Halldorson's exclusive new PLASKOIL employs a special process that virtually encapsulates vital windings—gives you 4-way better protection:

CORONA RESISTANT—Superior dielectric properties guard against *flash-overs* and *break-downs*.

HEAT RESISTANT—Permits safer "hot cage" operation.

NON-HYGROSCOPIC—Unexcelled protection against moisture.

STRUCTURALLY STRONGER—No chipping or cracking. Unlike wax, is not brittle.

Get Halldorson PLASKOIL units at your distributor today. *Better than originals.* Halldorson Transformer Co., 4500 Ravenswood, Chicago 40, Ill.

Halldorson

QUALITY Transformers SINCE 1913

**Only HALLDORSON
Gives You PLASKOIL!**

PHOTOGRAPHS

RADIO-ELECTRONICS can use good photographs of service benches, service shops, high-fidelity audio layouts, and any other interesting and original radio-electronic devices.

We will pay \$6.00 each for good professional photos or equivalent, suitable for reproduction.

Full information on subject photographed will increase their acceptability.

The Editor, RADIO-ELECTRONICS
25 West Broadway, New York 7, N. Y.



They're new —and go in fast!

Centralab Snap-Tite* Replacement Controls

Speed servicing of "hidden" or rear-end TV volume controls



Two fingers are all you need to install a Snap-Tite. Just push it into the chassis mounting hole — it snaps into place.

You need no tools — no nuts, lock-washers, or other hardware.



Six spring clips grip panel for positive, non-twisting mounting.

Shaft is molded, high strength polystyrene, fingertip knurled and slotted for screw-driver adjustment. Extends 1/2" from face of mounting surface.



Snap-Tite replaces any "short-shaft" standard control — and, at 45¢ net, costs you about 35¢ less!

You have less stock to carry — ten values replace 75% of current rear-end TV controls.

Order a supply of Centralab Snap-Tite Replacement Controls today from your Centralab distributor.

Send coupon for new Centralab Catalog No. 29 describing this and other new Centralab developments.

*Trademark



B-3454

TEAR OUT COUPON AND MAIL TODAY!

CENTRALAB, A Division of Globe-Union Inc. 922-H E. Keefe Avenue, Milwaukee 1, Wis.

Send me new Centralab Catalog No. 29

Name.....
 Company.....
 Address.....
 City.....Zone.....State.....

EDITORIAL

(Continued from page 29)

Editor, RADIO-ELECTRONICS

(4) "About your article, 'Wanted: Technicians,' about good pay and others. In your April editorial you mention specialists of the highest order!"

"Then you go on to say high grade men who must know all there is to be known about electronics (a thorough understanding of all phases of electronics). They must know, as you say, math, physics, transistors, etc. Also, you go on to say, not necessarily college education, but knowledge of everything connected with the art.

"Is there any one man living today who knows all! Even engineers themselves are only good at one line. It takes a lifetime and a long grey beard before one can even approach your so-called know-it-all superior man or technician."

Henry Chew
 Los Angeles, California

Answer: We refer you to our answer to letter number 3.

Editor, RADIO-ELECTRONICS

(5) "I only have one question, sir. Where can I get specialized education? I want to be a top-notch electronics technician, but I don't know where to start.

"Could you send me a list of schools, regardless of where they are, so that I can make a choice."

A. A. Dauplaise
 San Francisco, California

Answer: You are the only one who can really answer your question. Every technician and every engineer has certain inclinations towards certain electronic endeavors. Some men specialize in transmission, others in antennas, still others in hundreds of different electronic phases. Pick out a particular phase in electronics that appeals to you most, and specialize in it. You will then not be disappointed. Write also to your State Dept. of Education and to U.S. Education office for lists of schools giving radio and electronic instruction.

Editor, RADIO-ELECTRONICS

(6) "I became interested in the controversy regarding the shortage of specialists.

"I believe that specialists are individuals who have the intelligence, interest and ability to do the particular work in an outstanding manner. They cannot be made solely by so much education or by so many years of practical experience. I agree with Mr. Gernsback's editorial that the present practice is to take young men and start them off with a low salary, and they advance step by step in learning and wages. The selection of these men is usually done through the screening of applications. As a result, only a few out of the many employed become outstanding, since applications do not show intelligence, interest, or ability, and, besides, are easy to falsify. Quite often the starting pay is low for this type of work. The more ambitious or energetic type of person will turn to other types of employment, leaving the less desirables to choose from.

"One solution to this problem is to subject the prospective employe to a series of tests that will show his intelligence, interest and ability—give this smaller selected group a considerable increase in starting pay. The result will be more and better specialists."

Thomas L. Bartholomew
 Bridgeport, West Virginia

Answer: The above letter is self-explanatory and can give many employers as well as readers food for thought.

Editor, RADIO-ELECTRONICS

(7) "I have worked with radio and elec-

GREAT SAVINGS! Full Specials

TV PICTURE TUBES ONE YEAR GUARANTEE

10BP4 .. \$10.95	17BP4 .. \$16.95
12LP4 .. 11.95	17CP4 .. 17.95
12LP4A .. 12.95	17GP4 .. 18.95
12QP4 .. 12.95	17HP4 .. 18.95
12JP4 .. 12.95	19AP4 .. 19.95
14BP4 .. 13.95	19BP4 .. 18.95
16KP4 .. 15.95	19DP4 .. 18.95
16AP4 .. 16.95	20CP4 .. 19.95
16CP4 .. 16.95	21AP4 .. 22.95
16GP4 .. 16.95	21EP4 .. 21.95
16LP4 .. 16.95	21FP4 .. 22.95

All Prices With Old Tube
 Add \$5.00 deposit to tube price. Deposit is fully returned upon receipt of your old tube.

630-DX TECH-MASTER CHASSIS. \$145.00 with Cascade Tuner..... now

TV Wire, 300 ohm, 55 mil... 100 ft. \$1.00

MIDGET TV INDOOR ANTENNA, completely out of sight, yet outperforms rabbit ears. \$1.00 ea.

DEFLECTION YOKES
 60" Yokes..... 69c ea.
 70" Yokes..... \$1.95 ea.

New CASCADE Tuners
 Complete, \$14.95
 factory aligned 98c ea.

FP CONDENSER with Metal Plate, 4 Section 20/150 V. 3-20/20 V. 25c ea. 10 for \$1.95

Special! VARIABLE CONDENSERS
 2 gang super het 29c ea. 2 gang mini, type 89c ea.
 3 gang AM/FM 89c ea. Small single gang 98c ea.

CONTROLS
 2 meg. IRC..... 39c ea.
 Sw. for above. 9c ea.
 25K Type J, AB..... 6/89c
 180K Type J, AB..... 6/89c

CRYSTAL MIKES
 Removed from equipment, 60c ea.
 hearing aid type 3 for \$1.89

Miniature Chokes 29c ea.
 3 leads, 3K ohms hearing aid type, 4 for \$1.

WRITE FOR FREE NEW CIRCULAR. Terms: 25% dep. with order, bal. C.O.D. N.Y.C. Prices subject to change without notice.

ROSE ELECTRONICS, Inc.

76 Vesey St., New York 7, N.Y. CO. 7-6195

!! ALNICO MAGNETS !!

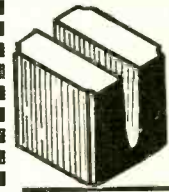

Just a few of the types always in stock:
 POLISHED BAR—9/16"x7/32"x 1/32"—12/\$1.00 100/\$7.50
 "U" TYPE—3/4"x 5/8"x 1/2" \$5.00
 RING TYPE—1-1/16" O.D. 3/8" I.D. 5/16" deep.....ca. 79c
 "HEELING" MAGNETS—1/2" x 2 round 5/8" O.D. bars, 4lb. & 13lb. L. Wood cased.....set \$1.98
 ALNICO MAGNET KIT—Powerful Bar, Block, "U" Rod, Etc. Kit of 10 asstd.....\$1.98
 (WRITE FOR LATEST ALNICO SUPPLEMENT)

TUBE CARTONS

TUBE CARTONS — plain white: prices per 100.
 Mini (1 1/2" sq. x 3 3/4") — \$1.20; GT (1 1/4" sq. x 3 1/4") \$1.45
 Med (1 1/2" sq. x 4 1/4") — \$1.65; Large (2" sq. x 5") \$1.98
 "FIBREGLASS" ACOUSTICAL CABINET LINING 1" thick, 36" wide—per running ft. \$1.15
 20 PUSH-BACK HOOK-UP WIRE — Red, Black, Yellow or Blue.....100 ft. \$6.95
 W-10B FIELD WIRE.....rolls 100-400 ft. 14c/ft.

TERRIFIC SAVINGS ON PARTS

with the new "JUMBO RADIO ELECTRONICS PARTS KIT" LOADED with new & surplus inventory odds & ends. WORTH SEVERAL TIMES THE PRICE!
 RESISTORS, CONDENSERS, TV PARTS & DIAGRAMS, PHOTOFACTS, WIRE, ETC. \$3.95 ETC. (shpg. wt. 20 lbs.).....ALL FOR

! CABINET DRAW SLIDES !

Heavy duty, all-steel. Silent ball-bearing action. Gun metal finish. 13" overall lgth. 9" extension per pair \$2.39—in lots of 12 \$2.15 per pair
 CABINET LID SUPPORTS (easy hinge) — holds console or trunk lid at any angle to 70°.....\$1.98
 EXPERIMENTAL TUBES.....ca. 39c
 Etc. Fil. tested. Kit of 40 asstd. revg. types.....\$1.98
 HI-FI CRYSTAL HAND MIKE — Hi-imped., rugged all-purpose 5 1/4" ft. shielded cable.....\$3.95
 "OUNCER" INPUT TRANSFORMER (1-1/8"x7/8").....S.B. carbon mike to grid.....ea. 98c 6/\$5.00

REPAIR YOUR OWN SPEAKERS

SPEAKER REPLACEMENT CONES.....An assortment of popular sizes 3" to 12", incl. oval. Less voice coils. Kit of 12 assorted.....\$1.98
 SPEAKER REPAIR KIT — Professional assortment of Voice Coil Forms, Rings, Spacers, Chamois Leather, Shim Kit, Cement & Instructions.....\$2.49
 "SPECIAL!".....BOTH CONE & REPAIR KIT FOR ONLY.....\$3.95

"DIRECT FACTORY SPEAKER REPAIRS SINCE 1927!" Min. Order \$3.00. 20% deposit req. on all C.O.D.'s. please add sufficient postage—excess refunded



EDITORIAL

tricity since the 1920s. I have a B.S. degree, an E.E. degree, and a Master's degree in Physics. Am a Registered Professional Engineer, and a member of four engineering societies. I frequently take refresher courses in math, and physics at Northwestern and Illinois Tech. Also hold a first-class commercial phone license.

"I have done consulting work throughout the United States and Mexico. I have written books on electricity and electronics, some under my own name, some under another. My present income ranges from \$10,000 to \$15,000.

"Frankly, I think that is a damned small income for the years I have spent learning my profession. *But—most of my friends in this business fail to come close to this.* Men with a background equal to my own—or better—are existing on \$100 a week, or a trifle better.

To learn first-hand the kind of jobs that are open to competent engineers, I answered ads for electrical and electronic engineers. Despite the glowingly worded advertisements, I have yet to receive an offer as high as \$6,000 a year. The harsh truth is that if I were forced to seek employment, I could earn more as a truck driver than I could in my own profession.

"I am forced to the conclusion that the widely advertised shortage of competent engineers is largely a myth. This belief is bolstered by the dozens of ads inserted in the *Chicago Tribune* each week by Electronic Engineers seeking employment."

Name Withheld by Request
Des Plaines, Illinois

Answer: *We cannot quite agree with our learned correspondent that the shortage of engineers is a myth. If this were true, would the firms continue to advertise right along? We rather believe that our reader has not been too successful in bringing himself forcefully to the notice of those concerns who can use his fine knowledge best. We admit, it is not always possible to connect with the right industry and the right employer at the right time. Here, again, what we said at the beginning of this editorial holds true. One must everlastingly keep at it to bring oneself to the notice of those who can best use one's services. This may take a long time, ingenuity, a lot of push, and much work.*

Editor, RADIO-ELECTRONICS

(8) "Perhaps all the unfavorable comment you've received regarding the editorial would have been avoided by entitling the piece, *'Wanted: Engineers.'*

"The only person I know of in the electronics field who are in position to command high salaries are graduate engineers. The technicians are, and will remain, salaried about the same as milk peddlers, truck drivers, etc. This really isn't too bad, because if a radioman gets disgusted enough with his lot, he can always shift to truck driving. In addition, he can supplement his income by repairing television and radio sets on the side."

Robert Barg
Webster, New York

Answer: *Perhaps it is best to refer our correspondent to our opening remarks.*

Editor, RADIO-ELECTRONICS

(9) "I would like to state that I have been in the communication field for 28 years. My service has not by any means been confined to one item of the field. I have done all the jobs they have and I consider myself a first-class man in my line. If I did not know my business, I would not receive the top pay of \$300.00 a month for my services. I can shoot trouble on wire, radio, and what circuits have you. I carry a first-class am-



more servicemen prefer

STANCOR

REPLACEMENT TRANSFORMERS

than all other brands combined*

because they like the . . .

- ease of installation
- completeness of the Stancor line
- availability of accurate replacement information
- rugged, breakdown-proof construction
- quick delivery from distributor's stock

*Brand Name Surveys, Chicago, Illinois; brand preference survey of electronic replacement components, May, 1954. Answered by servicemen from all over the U.S.

FREE NEW STANCOR GENERAL CATALOG listing over 500 transformers for TV, radio, high fidelity, communications and other electronic applications. Available from your local Stancor distributor or by writing Standard Division, Chicago Standard Transformer Corporation.

Stancor transformers
are listed in Photofact Folders and Counterfacts



CHICAGO STANDARD TRANSFORMER CORPORATION

3592 ELSTON AVENUE • CHICAGO 18, ILLINOIS

EXPORT SALES: Roburn Agencies, Inc.
431 Greenwich Street, New York 13, N. Y.

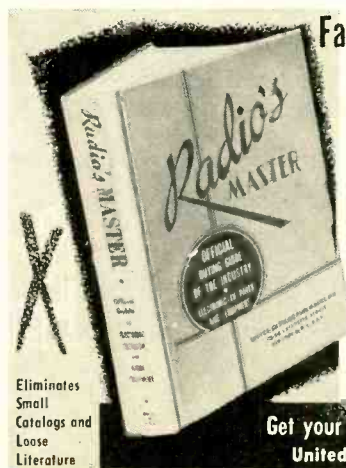

Faster, Easier, more PROFITABLE Operation

Get into the **MASTER** habit!

Brings you the product data of the industry in one handy book—all products vital to your daily sales and service operations. In the customer's home, across the counter or on the bench, you'll value the **MASTER'S** thoroughly complete descriptions, specs, illustrations and prices . . . all systematically organized in 18 big sections. Over 1300 pages of unabridged catalog data direct from the manufacturers. Keeps you abreast of all latest electronic products. Increase your sales and speed-up your buying—the **MASTER** way.

As **\$1.95** at your parts distributor. Publisher's price **\$6.50**.

OFFICIAL BUYING GUIDE OF ELECTRONICS-TV-RADIO INDUSTRY

- 1370 pages
- 8" x 11"—5 lbs.
- Over 8,000 illus.

Just a few of the more than 85,000 items included:

Tubes—Transmitters
Test Equip.—Receivers
Transformers
Capacitors—Antennas
Resistors—Wire & Cable
Coils & Relays
Recording & PA
Hardware & Tools

Get your **MASTER** now from leading parts distributors or write to:
United Catalog Publishers, Inc., 10 Lafayette St., N. Y. 13

When answering advertisements please mention
RADIO-ELECTRONICS

RADIO SCHOOL DIRECTORY

GET INTO ELECTRONICS

You can enter this uncrowded, interesting field. Defense expansion, new developments demand trained specialists. Study all phases radio & electronics theory and practice: TV, FM, broadcasting, servicing, aviation, marine, police radio. 18-month course. Graduates in demand by major companies. H.S. or equivalent required. Begin Jan., March, June, Sept. Campus life. Write for catalog.

VALPARAISO TECHNICAL INSTITUTE
Dept. C Valparaiso, Ind.



TELEVISION

PREPARE FOR A GOOD JOB!

BROADCAST ENGINEER
ELECTRONICS
RADIO SERVICING

Television Servicing

(Approved for Veterans)

SEND FOR FREE LITERATURE

BALTIMORE TECHNICAL INSTITUTE
1425 EUTAW PLACE, BALTIMORE 17, MD.

LEARN TV AT HOME

Here is your opportunity to learn TV servicing at home... a simple 14-week course written so you can understand it, priced so you can afford it.

This well-established, reputable TV and electronics school will send you complete lessons, tests and give you individual consultation, by correspondence.

The complete course costs only \$25.00. This is a limited offer so write today for information to:

VIDEO SPECIALTIES, INC., Dept. 616A
4508 E. Firestone Blvd., South Gate, Calif.



RCA INSTITUTES, INC.

A service of Radio Corporation of America
350 West 4th St., New York 14, N. Y.

OFFERS COURSES IN ALL TECHNICAL PHASES OF RADIO, TELEVISION, ELECTRONICS

Approved for Veterans
Write Dept. RE-54 for Catalog

RADIO ENGINEERING DEGREE IN 27 MONTHS

Intensive, specialized course including strong basis in mathematics and electrical engineering, advanced radio theory and design, television. Modern lab. Low tuition. Self-help opportunities. Also B.S. degree in 27 months in Aeronautical, Chemical, Civil, Electrical, and Mechanical Engineering. G.I. Gov't approved. Enter September, December, March, June. Catalog.

INDIANA TECHNICAL COLLEGE

1584 E. Washington Blvd., Fort Wayne 2, Indiana

GET INTO TV SERVICE

Send for free 24-page illustrated booklet which tells you how to become a successful TV technician. America's leading TV servicing school offers you a specialized training program that omits non-essential math & design theory. You concentrate on radio & TV servicing only. You get professional training & experience right in our fully-equipped shops & laboratories. Send for this booklet today. Write Dept. E-84. No obligation—no salesman will call. Approved for Veterans

WESTERN TELEVISION INSTITUTE

341 W. 18th St. Los Angeles 15, Calif.

MORE JOBS

than graduates

Demand for our engineering graduates exceeds supply. *Effective placement.* Study in this world-famed college established 1884. Quarters start September, January, March, June. *Approved for Korean Vets.*

Bach. Sc. degree in 27 months

Complete Radio Eng. courses... TV, UHF and FM. Also Mech., Civil, Elec., Chem., Aero. and Adm. Eng.; Bus. Adm., Acct. Small classes. Well-equipped labs. Modest costs. Prep. courses. Write *Jean McCarthy, Director of Admissions, for Catalog and Campus View Book.*



TRI-STATE COLLEGE

2484 College Avenue, Angola, Indiana

Get Your F.C.C. LICENSE Quickly!

Correspondence or residence preparation for F.C.C. examinations. Results guaranteed.

An FCC commercial operator license means greater opportunities and higher pay. We are specialists in preparing you, in a MINIMUM OF TIME, to pass FCC examinations for all classes of licenses. Beginners get 2nd class license in 5 weeks and 1st class in 3 additional weeks. Write for free booklet.

GRANTHAM School of Electronics

Dept. 101, 6064 Hollywood Blvd., Hollywood 28, Calif.



TV REPAIRMEN EARN TOP MONEY!

IN JUST 12 MONTHS, COMPLETE TV SERVICE TRAINING, INCLUDING COLOR TV. Streamlined course gives you all essentials for a good job as service technician. Graduates in great demand; jobs are plentiful in this growing field. Other electronic courses in radio operation and maintenance. Day or evening classes. Opportunity for employment in local industry. Approved for Korean veterans.

Write for Catalog 111 Today

INDIANAPOLIS ELECTRONIC SCHOOL
312 E. Washington, Indianapolis 4, Ind.

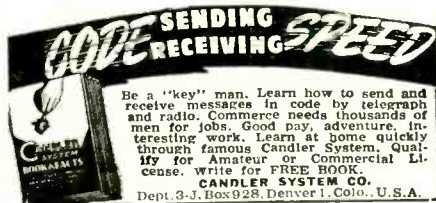

Be a "key" man. Learn how to send and receive messages in code by telegraph and radio. Commerce needs thousands of men for jobs. Good pay, adventure, interesting work. Learn at home quickly through famous Candler System. Qualify for Amateur or Commercial License. Write for FREE BOOK.

CANDLER SYSTEM CO.
Dept. 3-J, Box 928, Denver 1, Colo., U.S.A.

RADIO-TV ELECTRONICS



CREI graduates in big demand. Accredited by Engineers Council for Professional Development. New classes start every month. Free placement service for grads. Courses offered—Radio Engineering, Broadcast or TV Engineering, TV, FM, AM Servicing. Write for free catalog. Approved for Vets.

CAPITOL RADIO ENGINEERING INSTITUTE

Dept. RE. 3224—16th St., N.W., Washington 10, D. C.

Become an

ELECTRICAL ENGINEER

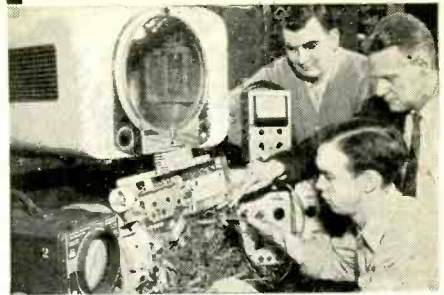

Major in Electronics or Power BS Degree in 36 months

Prepare now for a career as an electrical engineer or engineering technician — and take advantage of the many opportunities in these expanding fields.

You can save a year by optional year 'round study. Previous military, academic, or practical training may be evaluated for advanced credit.

Enter Radio and Television — courses 12 to 18 months

You can be a radio technician in 12 months. In an additional 6-months you can become a radio-television technician with Associate in Applied Science degree. Color television instruction is included in this program.

These technician courses may form the first third of the program leading to a degree in Electrical Engineering. Twenty-one subjects in electronics, electronic engineering and electronic design are included in these courses.

Courses also offered: radio-television service (12 mos.); electrical service (6 mos.); general preparatory (3 mos.).

Terms — September, January, April, July

Faculty of specialists. 50,000 former students—annual enrolment from 48 states, 23 foreign countries. Non-profit institution. 51st year. Courses approved for veterans. Residence courses only.

MS-6A



MILWAUKEE SCHOOL OF ENGINEERING

MILWAUKEE SCHOOL OF ENGINEERING
Dept. RE-854, 1025 N. Milwaukee Street
Milwaukee 1, Wisconsin

Send FREE illustrated booklets
 Career in Electrical Engineering.
 Career in Radio-Television.

I am interested in..... (name of course)

Name.....Age..

Address.....

City.....Zone.....State.....

If veteran, indicate date of discharge.....

SUBSCRIBERS

If you're moving, please don't forget to send us your address as it appears on the copy of the magazine, including the numbers shown beside your name, as well as your new address.

If we receive this information before the 20th of the month, you will continue getting the magazine without interruption.

Your cooperation will be most helpful and greatly appreciated.

NEW ANTENNA INVENTION IMPROVES TV RECEPTION

**CUTS INSTALLATION
COSTS UP TO 50%**

Newly patented antenna invention promises to bring about drastic changes in TV antennas and TV reception.

This amazing antenna is both revolutionary in design and principle, and runs completely contrary to all present day concepts of antenna theory.

This one single antenna is able to receive all television channels 2-83 from all directions WITHOUT ANY ROTOR MOTORS. It has also proven itself to be the finest for high fidelity FM reception and performs equally well in COLOR as in black-white.

While it performs up to ten times better than existing antennas, in most cases, it brings in stations presently considered out of range by existing antennas.

This new wonder antenna, truly an electronic miracle, is covered by 5 U. S. patents in which 53 claims have been granted. (#2,585,670; 2,609,503; 2,625,655; 2,644,091; 2,661,523.)

The television viewer can, by just a flick of the 9 position Electronic Orientation Switch, instantly and automatically beam any television set in any location to the best possible signal on any station coming from any direction.

It is now possible to put up just ONE antenna, use just ONE transmission line, pay for just ONE lower cost installation, and receive the finest possible reception from ALL stations in and coming to your area regardless of their direction.

This revolutionary, electronic, all direction antenna, is called

"The **Riviera**

It is the result of long and diligent research under both laboratory and field conditions.

ALL CHANNEL ANTENNA CORP.
47-39 49th STREET, WOODSIDE 77, N. Y.
EXETER 2-1336

EDITORIAL

ize. And I mean SPECIALIZE. Learn everything there is to know about one thing. Don't try to learn all about everything, because only God knows that. Take tubes, or transistors, or wave guides, or left-handed allen-screws, but specialize. You will have an excellent chance for a rewarding career. If you don't specialize, and learn a good deal about a lot of things, you will only qualify for mediocrity. In electronics, it takes a lot of knowledge to be mediocre, but the salary is true to form."

Robert M. Decker
Lyndhurst, New Jersey

Answer: An excellent explanation and a better answer to hundreds of letters which we received, than we could possibly write ourselves. We endorse most of the points.

Editor, RADIO-ELECTRONICS

(11) "Perhaps a short history of my own experiences would help to show what I mean. I took a correspondence course in radio when I was fourteen. When I was sixteen, I worked for a radio shop part-time for sixty-five cents per hour. This was 1944, when most beginning wages for factory workers was thirty to forty cents more. I graduated from high school in 1946, and worked two years for a take-home pay of thirty-five dollars weekly. I started my own shop in the basement of an electrical appliance store and did little better for two more years. Then a job came along for sixty-five a week, and not too long after, a raise to seventy-five. Then came the Army, from which I was discharged last October. I started my own shop again in a strange town. My shop is now beginning to show signs of life. By the end of this year, I hope to show a good profit. It took five years to double my beginning wage. It may take another five years to double it again. If it takes that long, I will still be only thirty years old. *It isn't today we must think of, but tomorrow. You can't start at the top of the ladder of success. You must first put your foot on the bottom rung. The climb will be tiring, but rewarding; and in the electronics field, the climb is getting higher every day. The sooner you can begin, the better.*"

Jack Buss
Tacoma, Washington

Answer: Still another phase of the same question in general, except that this correspondent is his own boss. The letter is most revealing.

Editor, RADIO-ELECTRONICS

(12) "Recently I answered an ad appearing in amateur radio publications, offering positions for electronics technicians. I felt I met the requirements as listed in the ad, but I followed their instructions and wrote for more information. Instead I received just a standard employment application form and a curt note to fill it in. Their answer to my application was a rude statement that they wanted no part of me. No explanation of where I lacked anything in meeting their requirements. Through much effort on my part, they finally said I was rejected because I have no industrial electronics experience. An item that never appeared in their ad.

"Now I ask you, how can I gain industrial electronics experience to obtain such a position if I cannot get the job to get the experience?"

"What am I supposed to do? Throw 20 years of experience and thousands of dollars in education down the drain and go hunt for a job in some other field where my talents might more adequately be rewarded."

Walter R. Whitcomb
Albany, Wisconsin

Answer: We have an impression that the presentation of this correspondent was inadequate. We point to the first part of the editorial which may give the remedy.

END

**Preferred for
Original Equipment
Proven for
Replacement**

**O
X
F
O
R
D**

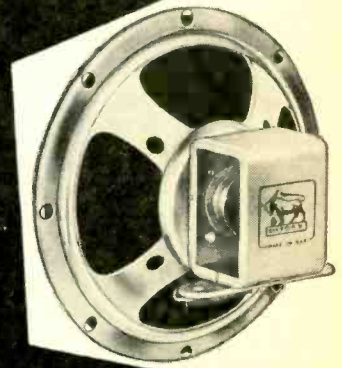

D Speakers

Available from leading jobbers!

OXFORD ELECTRIC CORP.

3911 S. Michigan Ave., Chicago 15, Ill.

EXPORT: ROBURN AGENCIES, N.Y.C., N.Y.

In Canada: Atlas Radio Corp., Ltd., Toronto

LEARN

**Television-Radio
Electricity**

REFRIGERATION-ELECTRONICS
IN THE GREAT
SHOPS OF **COYNE**

**TRAIN QUICKLY! OLDEST, BEST
EQUIPPED SCHOOL of ITS KIND in U.S.**

Come to the Great Shops of Coyne in Chicago. Get practical training in opportunity fields—TELEVISION-RADIO—ELECTRICITY—ELECTRONICS—vital in Defense Program. Prepare now for a better job in Industry or better service rating.

Approved for Veterans

Finance Plan—Enroll now, pay most of tuition later. If you need part-time work to help out with living expenses while at Coyne, we'll help you get it. Special tuition plan for men of Draft Age.

FREE BOOK Clip coupon for Big Free Illustrated Book. No salesman will call. Act NOW.

B. W. Cooke, President

COYNE SCHOOL A TECHNICAL TRADE INSTITUTE CHARTERED NOT FOR PROFIT Established 1899 500 S. Paulina, Chicago

**ELECTRICITY ★ TELEVISION
RADIO ★ REFRIGERATION ★ ELECTRONICS**

B. W. COOKE, Pres.

COYNE School
500 S. Paulina St., Chicago 12, Ill. Dept. C4-81H

Send FREE BOOK and full details on:

TELEVISION-RADIO ELECTRICITY

NAME.....

ADDRESS.....

CITY..... STATE.....

Compare! Save!.. on RAD-TEL TUBES and PARTS!

SAME DAY SERVICE—OVER 300 TYPES IN STOCK—NO GIMMICKS, JUST LOW-LOW PRICES!

70% to 90% OFF on TUBES INDIVIDUALLY BOXED FULL YEAR GUARANTEE!

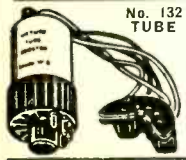

No. 132 CATHODE RAY TUBE REJUVENATOR
Fits all makes of picture tubes. Completely automatic. Easy to install. No tools needed. For A.C. parallel circuits. Your Old Picture Tubes Are Still Useful. List price \$5.95.

Lots of 10 **\$1.09**
Each **\$1.39**



Water Rotary Switch Kit
A choice combination of single, double, etc. from 2 to 8 positions. Special kit of 10.....
\$1.39

SPECIAL CLOSEOUTS

JAN TUBES
1619, 1626, 1629, 615, 7193, 954, 45 Special
27c each

AUTO GENERATOR CONDENSERS KIT OF 5
\$1.00



Philco TV BOOSTER
Completely self-contained, including 2 6J6 tubes, 1 for high channels and 1 for low channels and selenium rectifier. Plastic cabinet. In factory-sealed cartons, complete with instructions No. 125
\$9.95



STANDARD BOOSTER COMPLETE \$5.95

VARIABLE CONDENSERS

Manufactured by Philco, Radio Condenser, etc.

2 Gang AM and FM No. 9 Each Lots of 3
Contains 2 separate sections for AM and 2 for FM with padder condensers. With attached slug tuned high frequency coil whose plunger is geared to condenser shaft. Pulley type drive wheel.
89c 79c

2 Gang AM 3 Gang FM No. 10
Equipped with drum pulley and padders.
89c 79c

2 Gang Superhet No. 11
Complete with padders and drum pulley drive.
79c 69c

3 Gang AM Superhet No. 12
Complete with padders and pulley type drive wheel.
89c 79c

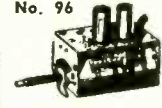

No. 96 Famous Standard Coil
CASCODE TUNER
Famous standard tuner TV front end. Double the gain with a great reduction in noise. A MUST for fringe area replacement. Includes tubes 6BK7 or 6BQ7 and 6J6.
\$14.95
List price \$34.50

ANODE CAPS 19c ea. Lots of 10 18c ea.



GRANCO "STAR" UHF CONVERTER
Brand new! Latest model! Unit is highly engineered, receives all UHF channels. Coaxial tuned cavity elements complete with 6AF4 oscillator, 6CB6 I-F and crystal mixer. Shipped ready to install and operate. List Price \$29.95.
\$22.45

All New Parts At Old Fashioned SAVINGS!

No. 82 HI-Watt RESISTOR KIT
Consisting of 5, 10, 15 and 20 Watt vitreous type resistors by Ward, I.R.C., etc. A top-flight buy!
ASSORTED KIT OF 20
Lots of 3 Kits
\$1.95 \$1.85 ea.

WEN SOLDERING GUN
3 seconds on 120 Volt AC ready to use for any soldering requirement. 250 Watt size. Also cuts plastic tile (with special tip). Multi-useful! UL Approved. Built in spot light. **9.71**
List price—\$12.95
Lots of 3, 8.64 Each
TIPS
Feraloy Long Life.....35c ea.
Standard Tip.....11c ea.
WEN POLISHER 10.46 ea. Lots of 3, 9.30 ea.

No. 47 CERAMICON KIT
1 kit of 50 assorted ceramic discs, biplates, tubular condensers. All condensers popular sizes, used in T.V. and F.M. sets. A MUST kit. List price—\$10.00.
\$1.99 Lots of 5 **\$1.89 ea.**

No. 44 10 inch SPEAKER
2.15 oz.
\$3.95 Lots of 5 **\$3.60 ea.**

T.V. RADIO and F.M. COIL KITS
Kit for television servicemen and experimenter consisting of wide coil, peaking coil, 4.5 m.c. ratio detector, and 21.9 m.c. IF coil.
TV, Standard kit of ten (10).....99c
TV, Super value: not duplicated 25—**\$1.85**
Broadcast and short-wave, midget to multi-band replacement coils. BC, Standard kit of ten (10). 99c
BC, Super value: not duplicated, **\$1.85**
Kit of 25. **\$1.85**
BC kits include RF, Osc., IF, and detector coils.

No. 46 HI-VOLTAGE R.F. COIL
4500 VOLTS RF TRANSFORMER
Ideal for T.V. and Oscilloscope power supplies, using 5" to 7" tubes. This buy is too BIG to be beaten! List price \$7.50.
79c Lots of 3 **69c ea.**

No. 75 ARMY-NAVY HEAD SETS
Individually boxed. Very sensitive. Meets both Army and Navy specifications. List price—\$16.00.
\$2.95 Lots of 3 **\$2.83 ea.** each per set

No. 107 DOUBLE FLYBACK
TR-172 Up to 13,5KV output. RCA Type Horizontal deflection transformer, with two filament windings for voltage doubler operation. First time at this low price.
\$1.89 ea. Lots of 3 **\$1.79 ea.**

Type	Price	Type	Price	Type	Price	Type	Price
OA2	.74	6AU6	.46	6Y6G	.48	14A4	.69
OA4	.68	6AV5GT	.83	7A4	.47	14A5	.59
OB2	.81	6AV6	.40	7A5	.59	14A7	.63
OC3	.72	6AX4GT	.65	7A6	.69	14AF7	.59
OD3	.70	6B4	.54	7A7	.69	14B6	.63
OZ4M	.65	6BA6	.49	7A8	.68	14B8	.63
IA5	.49	6BA7	.57	7AD7	.79	14C7	.79
1A7GT	.47	6BC5	.54	7AF7	.53	14E6	.75
1AX2	.62	6BD5	.59	7B4	.44	14E7	.88
1B3GT	.73	6BD6	.45	7B5	.45	14F7	.65
IC5	.43	6BE6	.51	7B6	.69	14H7	.59
IE7	.29	6BF5	.41	7B7	.49	14J7	.30
IG6	.24	6BF6	.37	7C4	.59	14N7	.84
IH4	.30	6BG6G	1.25	7C5	.69	14R7	.79
1H5GT	.49	6BH6	.53	7C6	.59	14S7	.89
1L4	.46	6BJ6	.49	7E5	.59	14W7	.30
1LA4	.59	6BK5	.80	7E6	.30	14X7	.69
1LA6	.69	6BK7	.80	7E7	.59	14Y7	.62
1LC5	.59	6BL7GT	.83	7F7	.79	19B6G	1.39
1LC6	.79	6BN6	.59	7G7	.89	19T8	.69
1LD5	.59	6BQ6GT	.98	7H7	.59	19V8	.79
1LE3	.59	6BQ7	.90	7J7	.79	24A	.39
1LG5	.69	6BZ7	.90	7K7	.69	25AV5GT	.83
1LH4	.69	6C4	.40	7L7	.59	25BQ6GT	.98
1LN5	.59	6C5	.39	7N7	.69	25L6GT	.51
1N5GT	.67	6C6	.58	7Q7	.66	25W4GT	.59
1P5GT	.57	6CB6	.54	7R7	.89	25Z5	.66
1Q5GT	.58	6CD6	1.11	7S7	.79	25Z6	.49
1R5	.62	6CF6	.64	7V7	.89	26	.45
1S4	.59	6CS6	.51	7X6	.54	27	.39
1S5	.51	6D6	.59	7X7	.70	32L7	.89
1T4	.58	6E5	.48	7Y4	.69	35	.58
1U4	.57	6F5GT	.39	7Z4	.59	35B5	.52
1U5	.50	6F6	.59	12A6	.54	35C5	.51
1V	.43	6G6	.42	12A8GT	.61	35L6GT	.51
2A2A	.63	6H6GT	.41	12AL5	.37	35W4	.47
2A3	.30	6J5GT	.43	12AQ5	.52	35Y4	.54
2W3	.38	6J6	.52	12AT6	.41	35Z3	.59
2X2	.49	6J7	.43	12AT7	.72	35Z4	.47
3A4	.45	6K5	.47	12AU6	.46	35Z5GT	.47
3E5	.46	6K6GT	.45	12AU7	.60	36	.39
3L4	.69	6K7	.44	12AV6	.39	42	.42
3Q4	.48	6L6	.64	12AV7	.73	45	.55
3Q5GT	.49	6L7M	.68	12AX4	.67	45	.55
3S4	.58	6N7M	.63	12AX7	.63	45Z3	.44
3V4	.58	6Q7	.45	12AY7	.99	45Z5	.49
5U4G	.55	6R7	.69	12AZ7	.59	50A5	.55
5W4GT	.50	6S4	.48	12BA6	.49	50B5	.52
5Y3GT	.37	6S78	1.90	12BA7	.60	50C5	.51
5Z3	.45	6S7M	.79	12BD6	.45	50L6GT	.61
6A6	.61	6S8GT	.53	12BE6	.51	50Y6	.49
6A7	.59	6SA7GT	.55	12BF6	.39	50Y7	.50
6AB4	.44	6SD7GT	.41	12BH7	.63	55	.49
6AC5	.69	6SF5GT	.46	12BY7	.65	56	.49
6AC7M	.86	6SG7GT	.41	12BZ7	.65	57	.58
6AF4	.90	6SH7GT	.49	12C8M	.34	58	.60
6AG5	.56	6SJ7GT	.41	12H6	.56	70L7	.97
6AG7M	.99	6SK7GT	.53	12SC7M	.63	75	.49
6AH4	.57	6SL7GT	.48	12J5	.42	76	.44
6AH6	.73	6SN7GT	.59	12J7	.49	77	.57
6AJ5	.65	6SQ7GT	.46	12K8	.59	78	.47
6AK5	.55	6SR7GT	.45	12Q7	.59	80	.43
6AK6	.59	6SS7GT	.42	12S8GT	.62	83V	.68
6AL5	.42	6T4	.99	12SA7GT	.65	84/6Z4	.46
6AM8	.78	6T8	.80	12SF5	.50	85	.59
6AQ5	.50	6U5	.57	12SG7	.51	117L7	.99
6AQ6	.37	6U6	.59	12SJ7M	.67	117P7	.99
6AQ7	.70	6U8	.78	12SK7GT	.63	117Z3	.37
6AR5	.45	6V6GT	.50	12SL7GT	.57	117Z6	.69
6AS5	.50	6W4GT	.47	12S7GT	.52	807	.99
6AS6	\$1.49	6W6GT	.57	12SQ7GT	.56	866A	1.39
6AT6	.41	6X4	.37	12SR7M	.49	Hi-Po #567	1.39
6AU4GT	.68	6X5GT	.37	12V6GT	.46		
6AU5GT	.82	6X8	.75	12X4	.38		

RAD-TEL TUBE CO. Dept. REB 115 Coit St., Irvington 11, N. J. "Integrity Is Our Chief Asset"

TERMS: A 25% deposit must accompany all orders—balance C.O.D. All shipments F.O.B. Irvington warehouse. ORDERS UNDER \$10—\$1.00 HANDLING CHARGE. Subject to prior sale.

PLEASE: Send full remittance . . . allow for postage and save C.O.D. charges! We refund all unused money!

Phone: Essex 5-2947

Tubes in Bold Type Cover 90% of Demand

Mr. Serviceman
check these
items for...
Value!



See your local
Parts Jobber



Align-o-Pak

Model BE2

Eliminates TV Alignment Bias Batteries. Provides voltages recommended by all TV manufacturers. Quickly diagnoses AGC trouble.

\$7.85

UHF HI-PASS FILTER



Model HP2

Passes UHF, rejects VHF up to 50 DB without tuning. Eliminates FM, Airport, Taxi cab interference, etc.

\$2.37



Up-Down
PATENT APPLIED FOR

VOLTAGE BOOSTER

Model LB2

Adds or subtracts 10 volts line voltage with heavy, safe toggle switches for any TV set. Line restored to normal when turned off.

\$5.97

PEAK-TO-PEAK Comparison Meter

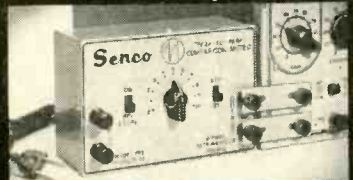

Add peak-to-peak measurements to your scope for only **\$8.75**
Handy for servicing gated AGC, gated sync separator, and essential for color.
Write for Additional Information

SERVICE INSTRUMENTS CO.
422 So. Dearborn—Chicago 5

ADVERTISING INDEX

Radio-Electronics does not assume responsibility for any errors appearing in the index below.

All Channel Antenna Corp.	126
Alliance Mfg. Co.	Inside Front Cover
Allied Radio Corp.	17
American Electric Heater Mfg. Co.	107
American Microphone Co.	100
American Phenolic Corp.	104
American Television and Radio Co.	89
Amplifier Corporation of America	113
Arky Radio Kits, Inc.	124
Astatic Corp.	18
Atlas Sound Corp.	82
Audel Publishers	90
Barry Electronics Corp.	128
Belden Manufacturing Co.	97
Bell Telephone Labs.	26
Bionder-Tongue Labs.	12
Brooks Radio & TV Corp.	101, 115
Cannon Electric Co.	110
Capital Radio Engineering Institute	22
Centralab—Division of Globe Union	90, 112, 122
Century Electronics Co.	124
Channel Master Corp.	7
Chicago Standard Transformer Corp.	123
Claroat Manufacturing Co.	91
Cleveland Institute of Radio Electronics	11
Collins Audio Products Co., Inc.	90
Columbia Electronics Corp.	124
Concord Radio	82
Cornell-Dubilier Electric Corp.	95
Cornish Wire Co.	90
Coyne Electrical & TV Radio School	94, 105, 126
DeVry Technical Institute	9
Dorian Electronics	117
Edlie Electronics	96
Electric Sweeper Service Co.	98
Electro-Voice Inc.	6
Electron Tube Wholesalers, Inc.	124
Electronic Instrument Co.	28, 93, 124
Electronic Measurements Corp.	102
Federal Telephone & Radio Company	83
General Industries Co.	98
General Test Equipment	124
Good, Inc., Don	117
Halldorson Transformer Co.	121
Heath Co.	65-68
Hudson Specialties Co.	120
Hughes Research & Development Labs.	82
Indiana Technical College	116
Instructograph Co.	117
International Correspondence Schools	13
International Rectifier Corp.	113
Jackson Electrical Instrument Co.	20
Jensen Industries	109
Jones & Laughlin Steel Corp.	119
Karlson Associates	109
Leotone Radio Corp.	122
MacMillan Co., The	120
Mailory & Co., Inc., P. R.	99
McGraw-Hill Book Co.	110
Moss Electronic Distributing Co.	74, 75
Muzak Corp.	79
National Electronics of Cleveland	94
National Radio Institute	3, 129
National Schools	5
Opportunity Adlets	115
Orradio Industries, Inc.	111
Oxford Electric Co.	126
Penman Electronics	98
Philco Corp.	24, 25
Precise Development Corp.	108, 109
Precision Apparatus Co., Inc.	92, 95
Progressive "Edu-Kits," Inc.	103
RCA Institutes, Inc.	15
RCA Victor Division (Radio Corp. of America)	Back Cover
Rad-Tel Tube Co.	127
Radelco Manufacturing Co.	88

RADIO SCHOOL DIRECTORY
PAGE 125

Baltimore Technical Institute	
Candler System Co.	
Capitol Radio Engineering Institute	
Grantham School of Electronics	
Indiana Technical College	
Indianapolis Electronic School	
Milwaukee School of Engineering	
RCA Institutes, Inc.	
Tri-State College	
Valparaiso Technical Institute	
Video Specialties	
Western Television Institute	
Radio Television Training Ass'n.	27
Raytheon Manufacturing Co.	10
Rider, Inc., John F.	100
Rinehart & Co., Inc.	88, 109
Rose Company	122
Sams & Co., Inc., Howard W.	16, 94
Sarkes Tarzian, Inc.	86
Service Instruments Co.	128
Shure Brothers, Inc.	16
Sprayberry Academy of Radio	63
Stan-Burn Radio and Electronics	116
Steve-El Electronics Corp.	113
Stuart Electronic Distributing Co.	86
Sylvania Electric Products	19
Tab	130
Technical Appliance Co.	73
Teltron Electric Co.	116
Terado Co.	106
Tipco Company	128
Transamerica Electronics	88
Transvision, Inc.	92
Triad Transformer Corp.	96
Trico Manufacturing Co.	21
Triplott Electrical Instrument Co.	Inside Back Cover
Tri Tech	124
Tung-Sol Electric Co.	8
United Catalog Publishers	123
V.A. Enterprises	116
Ward Products Corp.	23
Wester Electric Corp.	71
Windsor Electronic Tube Co.	93
Winegard Co.	14
Zingo Products	94

"TIP WRENCH" ADJUSTABLE SOCKET POCKET WRENCH

GETS NUTS, BOLTS and SCREWS into "Hard-To-Get-At" Places
HOLDS THEM FIRMLY WHILE TIGHTENING
"TIP WRENCH" IS BUILT TO WORK IN DEEP.
Holds nuts, bolts and screws where fingers can't hold them. It eliminates fumbling—SAVES VALUABLE MINUTES IN REPAIR or LINE PRODUCTION WORK. "TIP WRENCH" SPEEDS THE JOB—SAVES ITS COST MANY TIMES OVER. RUST PROOF. SHOCK PROOF.
—has tough Vinylite insulated shank. NO SLIP—PAGE WHEN "TIP WRENCH" GRIPS.

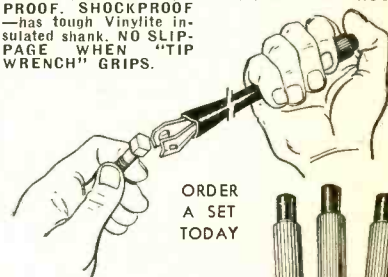

ORDER
A SET
TODAY

NEEDED IN EVERY
TOOL BOX & KIT

3 RIGHT SIZES

No. 1 For No. 2 to No. 8 Nut or Screw. 8 1/2" long.
No. 2 For No. 6 to No. 12 Nut or Screw. 8 3/4" long.
No. 3 For No. 6 to No. 12 Nut or Screw. 4 1/2" long. EACH **\$1.35**



Sold on a Money-Back Guarantee
ORDER THROUGH YOUR SUPPLIER

If he cannot furnish immediately, ORDER DIRECT and Give Supplier's Name. Or WRITE FOR DESCRIPTIVE LITERATURE.

TIPCO COMPANY

5865 Wilmington Ave., Los Angeles 1, Calif

"CAVEAT EMPTOR"

Tube
(Let The Buyer Beware)

Good advice for the modern serviceman! Today more and more used tubes are being sold in the guise of new tubes. They look good and most operate good... at first. But too many break-down 100, 8000.

Too often cheap prices and extravagant claims have fooled the buyer into purchasing these imitations, instead of the genuine article.

Barry Electronics sells first quality, fully guaranteed, individually boxed, STANDARD-BRAND Tubes. Our Tubes do not have to be "set or meter checked"... They are from original, sealed cartons from the five leading Tube manufacturers.

Cheap imitations such as seconds, rewashed bargains, and off-brands result in unnecessary call-backs, expense, and loss of customer good-will.

You can place your confidence in our new, first quality, fully-guaranteed STANDARD-BRAND Tubes.

WRITE TODAY FOR THE BARRY HANCOY-ORDER FORM, A COMPLETE LISTING OF STANDARD-BRAND RADIO & TV TUBES AT OVER 60% DISCOUNT.

AUTHORIZED DISTRIBUTORS
CBS-HYTRON EIMAC WESTINGHOUSE

SPECIAL-PURPOSE?
WE STOCK OVER 2000 TYPES!

TWO-COLORED TUBE CARTONS, with new Safety Partitions. Prevents Tube Breakage. This Super-Gloss Red and Black Carton is the Most Distinctive Box Available Today! Minimum: 100 any one size. Quantity prices on request.

SIZE	FOR TYPES SUCH AS	EACH
Miniature	(6AU6, 6AL5, etc.)	.50
GT	(6SN7, 6W4, etc.)	.0125
LARGE GT	(1B3, 6B06GT, etc.)	.015
LARGE G	(5U4G, 6B6GG, etc.)	.02

Terms: 25% with order, balance C.O.D.
All merchandise guaranteed. F.O.B., N.Y.C.

PHONE: REctor 2-2562

BARRY ELECTRONICS CORP.

136-B LIBERTY ST. N. Y. 6, N. Y.

An Invitation...

To men who want to "go places" in TV SERVICING

Find out about this NEW,
ALL-PRACTICE WAY
of becoming a Professional
TV SERVICEMAN

If you have some Radio or Television experience, or if you know basic Radio-Television principles but lack experience—NRI's new Professional Television Servicing course can train you to go places in TV servicing. This advertisement is your personal invitation to get a free copy of our booklet describing this training in detail.

Learn-by-Doing "All the Way"

This is 100% learn-by-doing, practical training. We supply all components, all tubes, including a 17-inch picture tube, and comprehensive manuals covering a thorough program of practice. You learn how experts diagnose TV defects quickly. You see how various defects affect receiver performance—picture and sound; learn causes of defects, accurately, easily, and how to fix them. You do more than just build circuits. You get practice recognizing, isolating, and fixing innumerable troubles.

You get actual experience aligning TV receivers, diagnosing the causes of complaints from scope patterns, eliminating interference, using germanium crystals to rectify the TV picture signal, obtaining maximum brightness and definition by properly adjusting the ion trap and centering magnets, etc. There isn't room on this or even several pages of this magazine to list all the servicing experience you get.

UHF & COLOR TV Making New Boom

Installing front-end channel selector strips in modern UHF-VHF Television receivers and learning UHF servicing problems and their solution is part of the practice you get. To cash in on the coming color TV boom you'll need the kind of foundation in knowledge and experience this training gives.

Get Details of New Course Free

Once again—if you want to go places in TV servicing, we invite you to find out what you get, what you practice, what you learn from NRI's new course in Professional Television Servicing. See pictures of equipment supplied, read what you practice. Judge for yourself whether this training will further your ambition to reach the top in TV servicing. We believe it will. We believe many of tomorrow's top TV servicemen will be graduates of this training. Mailing the coupon involves no obligation.

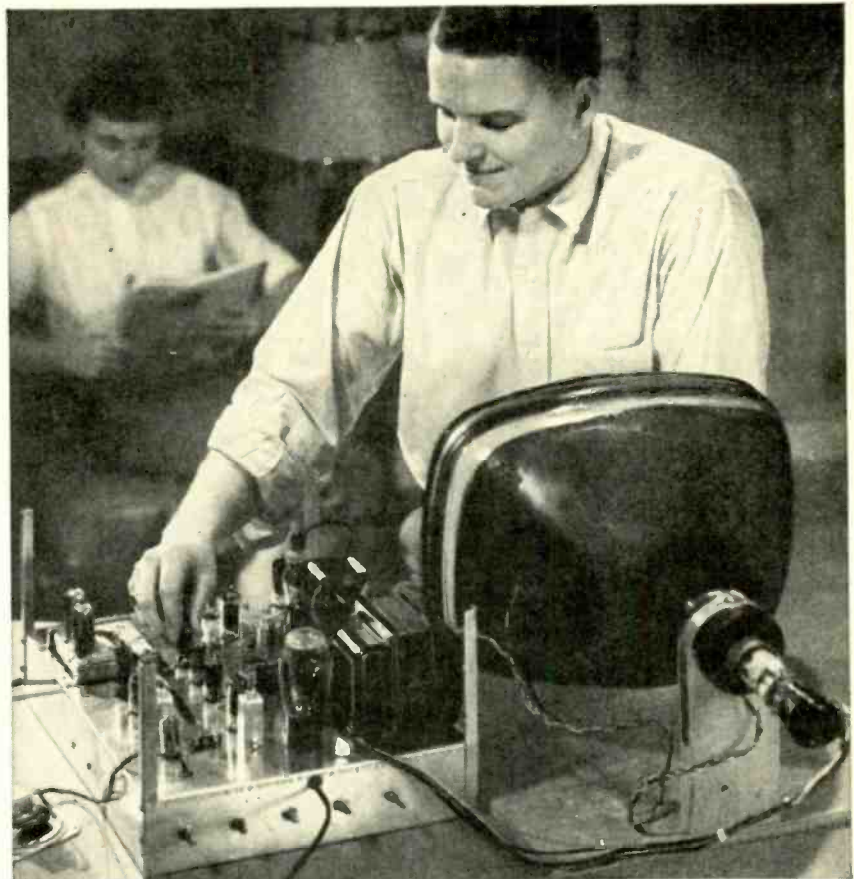

Train at home easily, quickly, for TV's top servicing jobs. NRI's Professional Television Servicing course includes a 17-inch picture tube and all other tubes and components to build a complete TV Receiver, Oscilloscope, Signal Generator, H.F. Probe. Complete training, including all equipment, available now for a low introductory price—under \$200 on easy terms.



National Radio Institute, Dept. 4HFT
16th and U Sts., N.W., Washington 9, D. C.

Please send my FREE copy of "How to Reach the Top in TV Servicing." I understand no salesman will call.

Name.....Age.....

Address.....

City.....Zone.....State.....



PAUL H. WENDELL

EDITOR AND PUBLISHER OF

SERVICE MANAGEMENT

WRITES ABOUT

THE MARK of the PROFESSIONAL

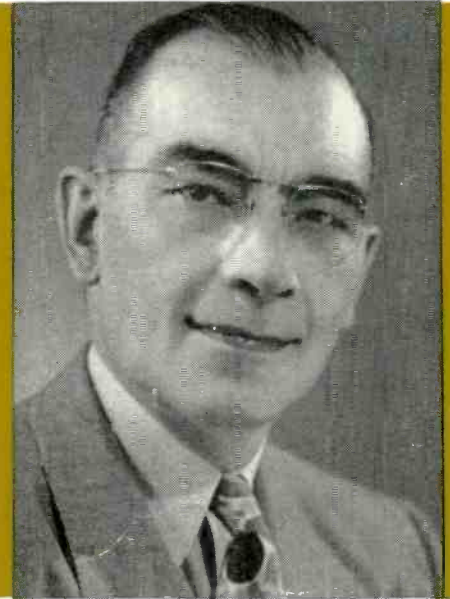

“... **I**n the television service shop of today an observer can quickly spot the expert professional technician by observing his *modus operandi* or manner of working. The tools of his profession are scopes, signal generators, tube testers and vacuum tube voltmeters. They are there at his fingertips—not for use on occasional jobs, but for consistent use on all jobs.”

Reprints of Mr. Wendell's complete article "The Mark of the Professional" are available at no cost from your parts jobber or from Triplett Electrical Instrument Co., Bluffton, Ohio.

Burton Browne advertising

TEST EQUIPMENT STANDARDS ARE SET BY

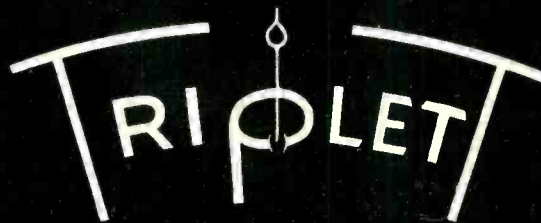

Model 650. Vacuum Tube Voltmeter \$69.50 net. One probe ACV and RF peak to peak measurements. One selector switch all ranges.



Model 3413-A. Tube Tester \$79.50 net. The only tester in its price range to get at each tube pin and make an open and short check.



Model 3436 UHF Marker-Signal Generator \$169.50 net. For calibrating front ends and converters—all that is needed in one instrument.



Model 3441 Oscilloscope \$199.50. Peak-to-Peak Voltmeter. Exclusive reversible polarity simplifies wave form reading.

RCA research
 is constantly at work
INSIDE EVERY
RCA TUBE



Same basic type number... better tube! RCA Receiving Tubes undergo continual improvement, to help you do a better job

Take an RCA Receiving Tube out of its famous red, white and black carton. Examine it! You're looking at a product of *constant development* by RCA Engineers — to give you superior tube performance and top tube value.

RCA is constantly improving tube design and making these advances without changing the basic type number. Yet RCA asks no premium for improvements! You get increased value with RCA Receiving Tubes!

Tubes shown here are typical examples of RCA's program of constant product improvement.

RCA-1B3-GT. This rectifier tube has been improved to handle the higher voltages required by "big-picture" TV sets. Tube safety factors have been increased through use of a special glass envelope and hydrogen firing of this envelope. Result: *Longer Life.*

RCA-6BQ6-GT. This horizontal deflection amplifier tube has been improved to minimize grid emission, stray emission, and TV picture "jitters." Result: *Superior Performance.*

RCA-6BQ7-A. Here's a miniature type twin triode with improved structure that does away with heater cathode trouble. Built to stand up in rf amplifier systems operating 24 hours a day. Replaces type 6BZ7 in practically every socket...offers equal performance at a lower price! Result: *Plus features, at no extra cost.*



When you sell a replacement tube, your profit and reputation are at stake. That's why it pays to use the best in Receiving Tubes—RCA.



RADIO CORPORATION of AMERICA
 ELECTRON TUBES

HARRISON, N. J.



ADV Plans, LLC

Copyright Notice:

The entire contents of this CD/DVD are copyright 2014 by ADV Plans, LLC. All Rights Reserved.

Reproduction or distribution of this disk, either free or for a fee is strictly prohibited. We actively monitor and remove listings on eBay thru Vero.

You are free to copy or use individual images in your own projects, magazines, brochures or other school projects.

Only the sellers listed here are authorized distributors of this collection:
www.theclassicarchives.com/authorizedsuppliers

Please view our other products at
www.theclassicarchives.com,
or our ebay stores:

[TheClassicArchives](#)
[ADVPlans](#)
[SuperShedPlans](#)

